



MOTOROLA

MTM800 ENH

**TETRA Mobile Terminal
806-870 MHz (MT912M)**

Detailed Service Manual

Part Number: 6866539D32-A



COPYRIGHT

Copyrights

© 2006 Motorola Inc. All rights reserved.

No part of this manual may be reproduced, transmitted, stored in a retrieval system, or translated into any language or computer language, in any form or by any means, without the prior written permission of Motorola Inc.

Computer Software Copyrights

The Motorola products described in this manual may include copyrighted Motorola computer programs stored in semiconductor memories or other media. Laws in the United States and other countries preserve for Motorola certain exclusive rights for copyrighted computer programs including, but not limited to, the exclusive right to copy or reproduce in any form the copyrighted computer program. Accordingly, any copyrighted Motorola computer programs contained in the Motorola products described in this manual may not be copied, reproduced, modified, reverse-engineered, or distributed in any manner without the express written permission of Motorola. Furthermore, the purchase of Motorola products shall not be deemed to grant either directly or by implication, estoppel, or otherwise, any license under the copyrights, patents or patent applications of Motorola, except for the normal non-exclusive royalty-free license to use that arises by operation of law in the sale of a product.

Trademarks

Motorola, the Motorola Logo and all other trademarks identified as such herein are trademarks of Motorola Inc. All other product or service names are the property of their respective owners.

THIS PAGE INTENTIONALLY LEFT BLANK

PRODUCT SAFETY and RF Energy Exposure for Mobile Two-Way Radios installed in Vehicles or as Fixed Site Control Stations



Caution

THIS CHAPTER IS AN EXTRACT OF THE MULTI LINGUAL MOBILE SAFETY BOOKLET PUBLICATION No. 6866537D37_.

FOR THE LATEST SAFETY INFORMATION REFER TO THE SEPARATE SAFETY BOOKLET DELIVERED WITH YOUR RADIO.

BEFORE USING THIS RADIO READ THIS INFORMATION WHICH CONTAINS IMPORTANT OPERATING INSTRUCTIONS FOR SAFE USAGE AND RF ENERGY AWARENESS AND CONTROL INFORMATION FOR COMPLIANCE WITH RF ENERGY EXPOSURE LIMITS IN APPLICABLE NATIONAL AND INTERNATIONAL STANDARDS.

The information provided in this document supersedes information contained in user guides, manuals and other documentation published prior to **February 2002**.

RF Energy Exposure Awareness and Control Information, and Operational Instructions for FCC Occupational Use Requirements.

Note: This radio is intended for use in occupational / controlled conditions, where users have full knowledge of their exposure and can exercise control over their exposure to meet FCC/ICNIRP limits. This radio device is NOT authorized for general population, consumer or any other use.

This 2-way radio uses electromagnetic energy in the radio frequency (RF) spectrum to provide communications between two or more users over a distance. It uses radio frequency (RF) energy or radio waves to send and receive calls. RF energy is one form of electromagnetic energy. Other forms include, but are not limited to, sunlight and x-rays. RF energy, however, should not be confused with these other forms of electromagnetic energy, which when used improperly, can cause biological damage. Very high levels of x-rays, for example, can damage tissues and genetic material.

Experts in science, engineering, medicine, health and industry work with organizations to develop standards for safe exposure to RF energy. These standards provide recommended levels of RF exposure for both workers and the general public. These recommended RF exposure levels include substantial margins of protection.

All Motorola 2-way radios are designed, manufactured and tested to ensure they meet government-established RF exposure levels. In addition, manufacturers also recommend specific operating instructions to users of 2-way radios. These instructions are important because they inform users about RF energy exposure and provide simple procedures on how to control it.

Please refer to the following Web sites for more information on what RF energy exposure is and how to control your exposure to assure compliance with established RF exposure limits.

<http://www.fcc.gov/oet/rfsafety/rf-faqs.html>

<http://www.osha.gov/SLTC/radiofrequencyradiation/index.html>

Federal Communications Commission Regulations (US markets only)

The FCC rules require manufacturers to comply with the FCC RF energy exposure limits for mobile 2-way radios before they can be marketed in the U.S. When 2-way radios are used as a consequence of employment, the FCC requires users to be fully aware of and able to control their exposure to meet occupational requirements. Exposure awareness can be facilitated by the use of a label directing users to specific user awareness information. Your Motorola 2-way radio has an RF exposure product label. Do not remove this RF exposure label from the device. Also, your Motorola user manual, or separate safety booklet, includes information and operating instructions required to control your RF exposure and to satisfy compliance requirements.

Compliance with RF Exposure Standard

Your Motorola radio is designed and tested to comply with a number of national and international standards and guidelines (listed below) regarding human exposure to radio frequency electromagnetic energy. **This radio complies with IEEE and ICNIRP exposure limits for occupational/controlled RF** exposure environments at duty factors of up to 50% talk–50% listen and is authorized by the IEEE/ICNIRP for occupational use. In terms of measuring RF energy for compliance with these exposure guidelines, your radio antenna radiates measurable RF energy only while it is transmitting (during talking), not when it is receiving (listening) or in standby mode.

Your Motorola two-way radio complies with the following RF energy exposure standards and guidelines:

- United States Federal Communications Commission, Code of Federal Regulations; 47 CFR part 2 sub-part J
- American National Standards Institute (ANSI) / Institute of Electrical and Electronic Engineers (IEEE) C95. 1-1992
- Institute of Electrical and Electronic Engineers (IEEE) C95.1-1999 Edition
- International Commission on Non-Ionizing Radiation Protection (ICNIRP) 1998
- Ministry of Health (Canada) Safety Code 6. Limits of Human Exposure to Radiofrequency Electromagnetic Fields in the Frequency Range from 3 kHz to 300 GHz, 1999
- Australian Communications Authority Radiocommunications (Electromagnetic Radiation - Human Exposure) Standard 2003
- ANATEL, Brasil Regulatory Authority, Resolution 256 (April 11, 2001) “additional requirements for SMR, cellular and PCS product certification.”

RF Exposure Compliance and Control Guidelines and Operating Instructions

To control exposure to yourself and others and to ensure compliance with the RF exposure limits, always adhere to the following procedures.

Guidelines:

- User awareness instructions should accompany device when transferred to other users.
- Do not use this device if the operational requirements described herein are not met.

Instructions:

- **Transmit no more that the rated duty factor of 50% of the time.** To transmit (talk), push the Push-To-Talk (PTT) button. To receive calls, release the PTT button. Transmitting 50% of the time, or less, is important because this radio generates measurable RF energy exposure only when transmitting (in terms of measuring for standards compliance).
- **Transmit only when people outside the vehicle are at least the recommended minimum lateral distance away, as shown in Table 1, from the body of a vehicle with a properly installed antenna.** This separation distance will ensure that there is sufficient distance from a properly installed (according to installation instructions) externally-mounted antenna to satisfy the RF exposure requirements in the standards listed above.

Note: Table 1 lists the recommended lateral distance for bystanders in an uncontrolled environment from the body of a vehicle with an approved, properly installed transmitting antenna (i.e. monopoles over a ground plane, or dipoles) at several different ranges of rated radio power for mobile radios installed in a vehicle.

Table 1

Mobile Radio Rated Power (see Note below)	Minimum Lateral Distance From Vehicle Body
Less than 7 Watts	20 cm (8 Inches)
7 to 15 Watts	30 cm (1 Ft)
16 to 39 Watts	60 cm (2 Ft)
40 to 110 Watts	90 cm (3 Ft)

Note: If you are not sure of the rated power of your radio, contact your Motorola representative or dealer and supply the radio model number found on the radio model label. If you cannot determine the rated power out, then assure 90cms (3 feet) separation from the body of the vehicle.

Mobile Antenna Installation Guidelines

- These mobile antenna installation guidelines are limited to metal body motor vehicles or vehicles with appropriate ground planes.
- Antennas should be installed in the centre area of the roof or the trunk lid taking into account the bystander exposure conditions of backseat passengers and according to the specific instructions and restrictions in the Radio. Installation Manual along with the requirements of the antenna supplier.
- Trunk lid installations are limited to vehicles with clearly defined flat trunk lids, and in some cases, to specific radio models and antennas. See the Radio Installation Manual for specific information on how and where to install specific types of approved antennas to facilitate recommended operating distances to all potentially exposed persons.

- **Use only Motorola-approved supplied antenna or a Motorola approved replacement antenna.** Unauthorized antennas, modifications, or attachments could damage the radio and may result in non-compliance with RF Safety Standards.

Approved Accessories

- This radio has been tested and meets the RF Safety Standards when used with the Motorola accessories supplied or designated for this product. Use of other accessories may result in non-compliance with RF Safety Standards.
- For a list of Motorola approved antennas, please see your dealer or local Motorola contact. Your nearest dealer can be found at the following web site:

<http://www.motorola.com/businessandgovernment/wemea/en-gb/public/functions/dealerlocator/dealerlocator.aspx>

Additional Information

- For additional information on exposure requirements or other training information, visit

<http://www.motorola.com/rfhealth>

Compliance and Control Guidelines and Operating Instructions for Mobile Two-Way Radios Installed as Fixed Site Control Stations

If mobile radio equipment is installed at a fixed location and operated as a control station or as a fixed unit, the antenna installation must comply with the following requirements in order to ensure optimal performance and compliance with the RF energy exposure limits in the standards and guidelines listed on previous page:

- The antenna should be mounted outside the building on the roof or a tower if at all possible.
- As with all fixed site antenna installations, it is the responsibility of the licensee to manage the site in accordance with applicable regulatory requirements and may require additional compliance actions such as site survey measurements, signage, and site access restrictions in order to insure that exposure limits are not exceeded.

Electromagnetic Interference/Compatibility

Note: Nearly every electronic device is susceptible to electromagnetic interference (EMI) if inadequately shielded, designed or otherwise configured for electromagnetic compatibility. It may be necessary to conduct compatibility testing to determine if any electronic equipment used in or around vehicles or near fixed site antenna is sensitive to external RF energy or if any procedures need to be followed to eliminate or mitigate the potential for interaction between the radio transmitter and the equipment or device.

Facilities

To avoid electromagnetic interference and/or compatibility conflicts, turn off your radio in any facility where posted notices instruct you to do so. Hospitals or health care facilities may be using equipment that is sensitive to external RF energy.

Vehicles

To avoid possible interaction between the radio transmitter and any vehicle electronic control modules, such as, ABS, engine, or transmission controls, the radio should be installed only by an experienced installer and that the following precautions be used when installing the radio:

1. Refer to the manufacturer's instructions or other technical bulletins for recommendations on radio installation.
 2. Before installing the radio, determine the location of the electronic control modules and their harnesses in the vehicle.
 3. Route all radio wiring, including the antenna transmission line, as far away as possible from the electronic control units and associated wiring.
-

Driver Safety

Check the laws and regulations on the use of radios in the area where you drive. Always obey them.
When using your radio while driving, please:

- Give full attention to driving and to the road.
- Pull off the road and park before making or answering a call if driving conditions so require.



OPERATIONAL WARNINGS

WARNING

For Vehicles With Air Bags

Do not mount or place a mobile radio in the area over an air bag or in the air bag deployment area. Air bags inflate with great force. If a radio is placed in the air bag deployment area and the air bag inflates, the radio may be propelled with great force and cause serious injury to occupants of the vehicle.

Potentially Explosive Atmospheres

Turn off your radio prior to entering any area with a potentially explosive atmosphere. Sparks in a potentially explosive atmosphere can cause an explosion or fire resulting in bodily injury or even death.

The areas with potentially explosive atmospheres referred to above include fuelling areas such as below decks on boats, fuel or chemical transfer or storage facilities, areas where the air contains chemicals or particles, such as grain, dust or metal powders. Areas with potentially explosive atmospheres are often but not always posted.

Blasting Caps And Blasting Areas

To avoid possible interference with blasting operations, turn off your radio when you are near electrical blasting caps, in a blasting area, or in areas posted:
"Turn off two-way radio". Obey all signs and instructions.

For radios installed in vehicles fueled by liquefied petroleum gas, refer to the (U.S.) National Fire Protection Association standard, NFPA 58, for storage, handling, and/or container information. For a copy of the LP-gas standard, NFPA 58, contact the National Fire Protection Association, One Battery Park, Quincy, MA.

**Caution****ADDITIONAL IMPORTANT INFORMATION
FOR SERVICING AND INSTALLING THE RADIO**

Only specialized workshops should be contacted for installation, maintenance and repair work.

This unit is equipped with protection fuses in the Power and Ignition Sense Cable.
Replace these fuses only with the original ratings!

**Caution: Failure to use correct manufactures approved parts
may result in physical damage to this unit.**

Fuse for Power Cable GKN6270/GKN6274: 10A (Motorola Part Number: 65C80283E05)
Fuse for Ignition Sense Cable HKN9327: 4A (Motorola Part Number: 65C80283E02)

**Achtung****ZUSÄTZLICHE SICHERHEITS INFORMATIONEN FÜR
SERVICE UND INSTALLATION DES FUNKGERÄTES**

Installations, Wartungs- und Reparaturarbeiten dürfen ausschließlich von autorisiertem und geschultem Personal ausgeführt werden.

Dieses Gerät ist mit einer Schutzsicherung im Stromversorgungskabel ausgestattet.
Bei Austausch ausschließlich den Originalwert verwenden

**WARNUNG: Bei Einsetzen von nicht vom Hersteller freigegebenen Ersatzteilen
kann das Gerät zerstört werden.**

Sicherung für Stromversorgungskabel GKN6270/GKN6274: 10A (Motorola Best.-Nr.:65C80283E05)
Sicherung für Zündungserkennungskabel HKN9327: 4A (Motorola Best.-Nr.:65C80283E02)

THIS PAGE INTENTIONALLY LEFT BLANK

CHAPTER 1

SCOPE & WARRANTY INFORMATION

SCOPE OF THIS MANUAL

This manual is intended for use by trained service technicians familiar with similar types of equipment only. It contains information required for the installation of the equipment described and is current as of the printing date. Changes which occur after the printing date may be incorporated by a complete Manual revision or alternatively as additions.

NOTE **Before planning or starting the installation, please read the Safety Information Section in the front of this manual.**

This manual is divided into the following sections:

- Copyright
- Document History
- User Safety, Training and General Information
- CHAPTER 1 Scope & Warranty Information
- CHAPTER 2 Model Information & Accessories
- CHAPTER 3 Overview
- CHAPTER 4 Theory of Operation
- CHAPTER 5 Programming
- CHAPTER 6 Testsetup & Testing
- CHAPTER 7 Maintenance
- CHAPTER 8 Schematic Diagrams, PCBs and Parts Lists
- CHAPTER 9 Troubleshooting
- Appendix A Connector Pin Functions
- Appendix B Replacement Parts and Kits
- Appendix C Retrofitting the GPS and UCM board
- Appendix D Product Specific Information

EMEA Manuals & User Guides

Product Information Manual

6866537D87 MTM800 Product Information (and programming) Manual

Installation Instructions

6866534D67 MTM700/MTM800 Installation Manual (English)

Service Manuals

6866537D72 MTM800 380-430MHz Detailed Service Manual (English)

6866537D98 MTM800 450-470MHz Detailed Service Manual (English)

6866539D02 MTM800 806-870MHz Detailed Service Manual (English)

6866537D20 MTM800 Basic Service Manual (English)

User Guides (Enhanced Control Head)

6866537D67 MTM800 Basic User Guide (EN / DE / FR / ES / NL)

6866537D95 MTM800 Basic User Guide (EN / SV / RU / IT / PL)

6866537D69 MTM800 Feature User Guide (English) only available on MOL:
(<https://emeaonline.motorola.com>)

User Guides (Motorcycle Control Head)

6866537D68 MTM800 Basic User Guide (EN / DE / FR / ES / NL)

6866537D96 MTM800 Basic User Guide (EN / SV / IT)

6866537D70 MTM800 Feature User Guide (English) only available on MOL:
(<https://emeaonline.motorola.com>)

Configuration Manual (Expansion Head Radio)

6866537D82 MTM800 Configuration Manual (English)

Safety Leaflets

6864117B25 Portable Safety Booklet

6866537D37 Mobile Safety Booklet

LACR Manuals & User Guides

Product Information Manual

6866537D87 MTM800 Product Information (and programming) Manual

Installation Instructions

6866534D67 MTM700 Installation Instructions (English)

Service Manual

6866537D72 MTM800 380-430MHz Detailed Service Manual (English)
6866537D98 MTM800 450-470MHz Detailed Service Manual (English)
6866539D02 MTM800 806-870MHz Detailed Service Manual (English)
6815900H01 MTM800 Basic Service Manual (English)

User Guides

6881097C65 MTM800 STD Basic User Guide (English, Spanish, Portuguese)
6881097C66 MTM800 M/C Basic User Guide (English, Spanish, Portuguese)
6881097C67 MTM800 Data Terminal User Guide (English, Spanish, Portuguese)

CPS Start Up Manual

6881097C68 MTM800 CPS Start Up Manual (English, Spanish, Portuguese)

CD ROM

9964416H09 MTM800 Documentation CD
(includes 6881097C65, 6881097C66, 6881097C67 and 6881097C68)

Safety Leaflets

6804112J96 Mobile Safety Leaflet (APAC & LACR)
6804113J25 Portable Safety Leaflet (APAC & LACR)

Warranty and Service Support

Motorola offers long term support for its products. This support includes full exchange and/or repair of the product during the warranty period, and service/ repair or spare parts support out of warranty. Warranty Period and Return Instructions

The terms and conditions of warranty are defined fully in the Motorola Dealer or Distributor or Reseller contract. These conditions may change from time to time and the following notes are for guidance purposes only. In instances where the product is covered under a "return for replacement" or "return for repair" warranty, a check of the product should be performed prior to shipping the unit back to Motorola. This is to ensure that the product has been correctly programmed or has not been subjected to damage outside the terms of the warranty.

Prior to shipping any terminal back to the appropriate Motorola warranty depot, please contact Customer Resources or your Motorola dealer, distributor or reseller. All returns must be accompanied by a Warranty Claim Form, available from your Customer Service representative or Motorola Online Extranet (MOL) or your Motorola dealer, distributor or reseller (refer to list in Appendix A). Products should be shipped back in the original packaging, or correctly packaged to ensure no damage occurs in transit.

After Warranty Period

After the Warranty period, Motorola continues to support its products in two ways.

- Motorola's Regional Radio Support Centres offer a repair service to both end users and dealers at competitive prices.
- AAD supplies individual parts and modules that can be purchased by dealers who are technically capable of performing fault analysis and repair.

CONTENTS

COPYRIGHT

Copyrights	ii
Computer Software Copyrights	ii
Trademarks	ii

DOCUMENT HISTORY III

PRODUCT SAFETY AND RF ENERGY EXPOSURE

RF Energy Exposure Awareness and Control Information	v
Federal Communications Commission Regulations (US markets only)	vi
Compliance with RF Exposure Standard	vi
Your Motorola two-way terminal	vi
RF Exposure Compliance and Control Guidelines	vi
Mobile Antenna Installation Guidelines	vii
Approved Accessories	viii
Additional Information	viii
Compliance and Control Guidelines and Operating Instructions	viii
Electromagnetic Interference/Compatibility	viii
Facilities	ix
Vehicles	ix
Driver Safety	ix
OPERATIONAL WARNINGS	x
For Vehicles With Air Bags	x
Potentially Explosive Atmospheres	x
Blasting Caps And Blasting Areas	x
ADDITIONAL IMPORTANT INFORMATION	xi
ZUSÄTZLICHE SICHERHEITS INFORMATIONEN	xi

TABLE OF CONTENTS XIII

CHAPTER 1 SCOPE & WARRANTY INFORMATION

SCOPE OF THIS MANUAL	1-1
EMEA Manuals & User Guides	1-2
LACR Manuals & User Guides	1-3
Warranty and Service Support	1-4
After Warranty Period	1-4

CHAPTER 2 MODEL INFORMATION & ACCESSORIES

MTM800 Mobile Terminal Model Information	2-1
Sales Model Nomenclature	2-1
Model Specifications	2-2
Model Descriptions	2-2
MTM800 Accessories-To-Model Chart	2-3

CHAPTER 3**OVERVIEW**

General	3-1
Digital Modulation Technique	3-1
Voice Compression Technology	3-1

CHAPTER 4**THEORY OF OPERATION**

Section Introduction	4-1
----------------------------	-----

CHAPTER 4.1**THEORY OF OPERATION (TRANSCEIVER)**

Block Diagram and Overview	4.1-1
Receiver Section	4.1-2
Transmitter Section	4.1-3
Controller Section	4.1-3
Frequency Generating Section	4.1-4
GPS Section	4.1-4
Block Diagrams Descriptions	4.1-5
Receiver Path	4.1-5
Transmitter Path	4.1-6
Frequency Generating Section	4.1-7
Main Synthesizer	4.1-8
Transmit frequency translation loop	4.1-8
Controller Section	4.1-9
Detailed Circuit Description	4.1-10
Receiver Path, Detailed Circuit Description	4.1-10
Antenna Switch	4.1-10
AGC_0 Attenuator	4.1-10
Pre Selector Filter	4.1-10
LNA and AGC_1 Attenuator	4.1-10
Second Pre-selector	4.1-10
Mixer	4.1-11
IF Filter, Amplifier, AGC_2 Attenuator	4.1-11
IF Digitizing Subsystem	4.1-11
Transmitter Path, Detailed Circuit Description	4.1-12
ADDAG	4.1-12
Tx LO	4.1-12
JAVELIN	4.1-12
RF Power Amplifier	4.1-13
Directional Coupler and RF Feedback Path	4.1-13
Antenna Switch	4.1-13
Harmonic Filter	4.1-13
Frequency Generating Section Detailed Circuit Description	4.1-14
Reference Oscillator - TCXO	4.1-14
Main VCO and Main Synthesizer	4.1-14
Transmit Frequency Translation Loop	4.1-15
Controller Section	4.1-16
DC Power Distribution	4.1-16
Microprocessor	4.1-18
Host Memories	4.1-19
Terminal Audio System	4.1-21
General purpose inputs and outputs	4.1-23
GPS Sub Module	4.1-24

CHAPTER 4.2**THEORY OF OPERATION (CONTROL HEADS)**

Enhanced Control Head	4.2-1
Power Supplies	4.2-1
Voltage Regulator Circuit	4.2-1
Power On / Off	4.2-2
Microprocessor Circuit	4.2-2
SBEP Serial Interface	4.2-3
Keypad Keys	4.2-3
Status LED and Back Light Circuit	4.2-3
Liquid Crystal Display (LCD)	4.2-4
Microphone Connector Signals	4.2-4
Electrostatic Transient Protection	4.2-5
Expansion Head	4.2-6
Overview	4.2-6
General	4.2-6
Circuit Description	4.2-6
Remote Mount Head	4.2-7
General	4.2-7
Description	4.2-7
Motorcycle Control Head	4.2-8
Power Supplies	4.2-8
Volume Control / ON/OFF Switch	4.2-8
Micro controller (U4)	4.2-8
Crystal Oscillator	4.2-8
LCD Display	4.2-8
Backlight	4.2-8
Controller	4.2-9
Power Supplies	4.2-9
Temperature Sensor	4.2-9
Keypad	4.2-9
Backlight	4.2-9
External Microphones and Speakers	4.2-9
Helmet	4.2-9

CHAPTER 5**PROGRAMMING THE TERMINAL****CHAPTER 6****TEST SETUP & TESTING**

Typical Test Setup	6-1
Before Testing	6-1
Test Equipment	6-2
Test Check List	6-3
Receiver Tests	6-4
Transmitter Tests	6-4
Call Processing Tests	6-4
Duplex Test	6-4
Configuration of the IFR 2968 System Setup	6-5
Configuration of the IFR 2968 Manual Test Screen	6-8
RF Tests	6-9
Receiver Tests	6-9
Simulate Base Station (registration)	6-9
RSSI Test	6-9
Transmitter Tests	6-10
Call Processing Test	6-11
Talk Back	6-11

Call to Mobile	6-11
Duplex Test (Phone/Private Mode)	6-11
Digital Duplex Test (Tx)	6-11
Service Flow Chart (Board Level)	6-13
Fuses on the Mainboard	6-14

CHAPTER 7 MAINTENANCE

Introduction	7-1
Preventive Maintenance	7-1
Inspection	7-1
Cleaning	7-1
Cleaning External Plastic Surfaces	7-2
Cleaning Internal Circuit Boards and Components	7-2
Safe Handling of CMOS and LDMOS Devices	7-3
Pre-baking of Integrated Circuits	7-4
Repair Procedures and Techniques - General	7-4
Parts Replacement and Substitution	7-4
Disassembling and Reassembling the Terminal - General	7-5
Terminal Disassembly and Reassembly - Detailed	7-5
Control Head Removal	7-5
Top Plastic Cover Removal	7-6
Transceiver Board Removal	7-7
Reassembly the Terminal Chassis And Transceiver Board	7-8
Control Head Fitting	7-8
Enhanced Control Head - Disassembly	7-9
Enhanced Control Head - Reassembly	7-10
Remote Mount Head - Disassembly	7-11
Remote Mount Head - Reassembly	7-12
Expansion Head - Disassembly	7-13
Expansion Head - Reassembly	7-14
Motorcycle Control Head - Disassembly	7-15
Motorcycle Control Head - Reassembly	7-16
Service Aids	7-16
EXPLODED VIEWS & PARTS LISTS	7-17
Transceiver - Exploded View and Parts List	7-17
Enhanced Control Head - Exploded View and Parts List	7-19
Expansion Head - Exploded View and Parts List	7-20
Remote Mount Head - Exploded View and Parts List	7-21
Motorcycle Control Head - Exploded View and Parts List	7-23

CHAPTER 8 SCHEMATICS, PCBS AND PARTS LISTS

Section Introduction	8-1
----------------------	-----

CHAPTER 8.1 SCHEMATICS, PCBS AND PARTS LISTS (TRANSCEIVER)

CHASSIS_OVERVIEW TRANSCEIVER	8.1-4
PCB / Main Board TOP SIDE	8.1-5
PCB / Main Board BOT SIDE	8.1-6
TX-LOW SECTION (JAVELIN)	8.1-7
PA SECTION	8.1-8
ABACUS Section	8.1-9
FRAC-N Section	8.1-10
FE and Mixer Section	8.1-11
RX VCO Section	8.1-12

TX VCO Section	8.1-13
Controller Power Supply Section	8.1-14
I/O Section	8.1-15
Controller Section	8.1-16
Port Controller Section	8.1-17
PATRIOT Controller Section	8.1-18
PATRIOT Memory Section	8.1-19
Controller Audio Section	8.1-20
Controller USB/ADC Section	8.1-21
GPS Sub Module PCB TOP & BOT side	8.1-22
GPS Sub Module Schematic	8.1-23
PARTS LISTS	
Parts on the Mainboard.	8.1-24
Parts on the GPS Board	8.1-30

CHAPTER 8.2 SCHEMATICS, PCBS AND PARTS LISTS (CONTROL HEADS)

ENHANCED_CONTROL_HEAD / BOT & TOP	8.2-2
ENHANCED_CONTROL_HEAD / Schematic 1	8.2-3
ENHANCED_CONTROL_HEAD / Schematic 2	8.2-4
ENHANCED_CONTROL_HEAD / Schematic 3	8.2-5
ENHANCED_CONTROL_HEAD / Schematic 4	8.2-6
EXPANSION_HEAD / Exp. Board BOT & TOP	8.2-7
EXPANSION_HEAD / Exp. Board / Schema.	8.2-8
EXPANSION_HEAD / SB 9600 interface / Schematic Diagram	8.2-9
PCB / EXPANSION_HEAD / Connector Board / BOT & TOP SIDE	8.2-10
EXPANSION_HEAD / Connector Board / Schematic Diagram	8.2-11
PCB / REMOTE_MOUNT_HEAD / BOT & TOP	8.2-12
REMOTE_MOUNT_HEAD Schematic Diagram	8.2-13
PCB / MOTORCYCLE_CONTROL_HEAD / BOT & TOP SIDE	8.2-14
MOTORCYCLE_CONTROL_HEAD (Sheet 1)	8.2-15
MOTORCYCLE_CONTROL_HEAD (Sheet 2)	8.2-16
PARTS LIST	
Enhanced Control Head	8.2-17
Expansion Head / Expansion Board	8.2-19
Expansion Head / Connector Board	8.2-19
Remote Mount Head	8.2-19
Motorcycle Control Head	8.2-20

CHAPTER 9 TROUBLESHOOTING

Section Introduction	9-1
General	9-1
Test Procedures	9-1
Troubleshooting Setup	9-1
Troubleshooting Flowcharts	9-3

TROUBLESHOOTING CHARTS

Main Function Test Chart (Sheet 1) >> Startup Procedure <<	9.1-2
Main Function Test Chart (Sheet 2)	9.1-3
Controller Troubleshooting (Sheet 1)	9.1-4
Controller Troubleshooting (Sheet 2)	9.1-5
DC Supply Troubleshooting	9.1-6
GPIO Troubleshooting	9.1-7
Receiver Audio Troubleshooting	9.1-8

Transmitter Audio Troubleshooting	9.1-9
Warping Failure Troubleshooting	9.1-10
RF Power Amplifier Troubleshooting	9.1-11
PA Bias Failure Troubleshooting	9.1-12
JAVELIN Troubleshooting	9.1-13
Receiver Troubleshooting (Sheet 1)	9.1-14
Receiver Troubleshooting (Sheet 2)	9.1-15
Front-End Tuning Troubleshooting	9.1-16
Tx Frequency Generation Troubleshooting	9.1-17
Main VCO Troubleshooting	9.1-18
Main Synthesizer Troubleshooting	9.1-19
GPS Troubleshooting (Sheet 1)	9.1-20
GPS Troubleshooting (Sheet 2)	9.1-21

APPENDIX A CONNECTOR PIN FUNCTIONS

Transceiver Rear - Pin Function	A-1
Transceiver Front - Pin Function	A-3
Enhanced Control Head - Pin Function	A-5
Remote Mount Head - Pin Function	A-7
Expansion Head - Pin Function	A-8
Motorcycle Control Head - Pin Function	A-10

APPENDIX B REPLACEMENT PARTS & KITS

Servicing MTM800 Mobile Units	B-1
Level 1 and Level 2 Maintenance	B-1
Level 3 Maintenance	B-1
Replacement Parts	B-1
SERVICE INFORMATION	B-2
Europe, Middle East and Africa Region	B-2
Asia, Pacific Region	B-3
Latin America Region	B-4
SERVICE KITS	B-6

APPENDIX C RETROFITTING THE GPS AND UCM MODULE

Retrofitting the GPS board	C-1
Retrofitting the UCM board	C-2

APPENDIX D PRODUCT SPECIFIC INFORMATION

Equipment Electrical Ratings	D-1
Normal Load Conditions:	D-1
Fuse Identification	D-1

SPEZIELLE PRODUKTINFORMATIONEN	D-2
Nennwerte für das Funkgerät	D-2
Betriebsbedingungen	D-2
Sicherungen	D-2

CHAPTER 2

MODEL INFORMATION & ACCESSORIES

MTM800 Mobile Terminal Model Information

This manual applies to the following Mobile Terminal Models

Type No.	Sales Model No.	Short Description	Model
MT912M	M80UCS6TZ5AN	MTM800 ENH 806-870 Dash	M1
MT912M	M80UCS6TZ4AN	MTM800 ENH 806-870 Desk	M2
MT912M	M80UCS6TZ6AN	MTM800 ENH 806-870 Remote	M3
MT912M	M80UCS6TZ2AN	MTM800 ENH 806-870 M'cycle	M4

Note: For identification of service tanapa numbers please refer to appendix B "REPLACEMENT PARTS & KITS".

Sales Model Nomenclature

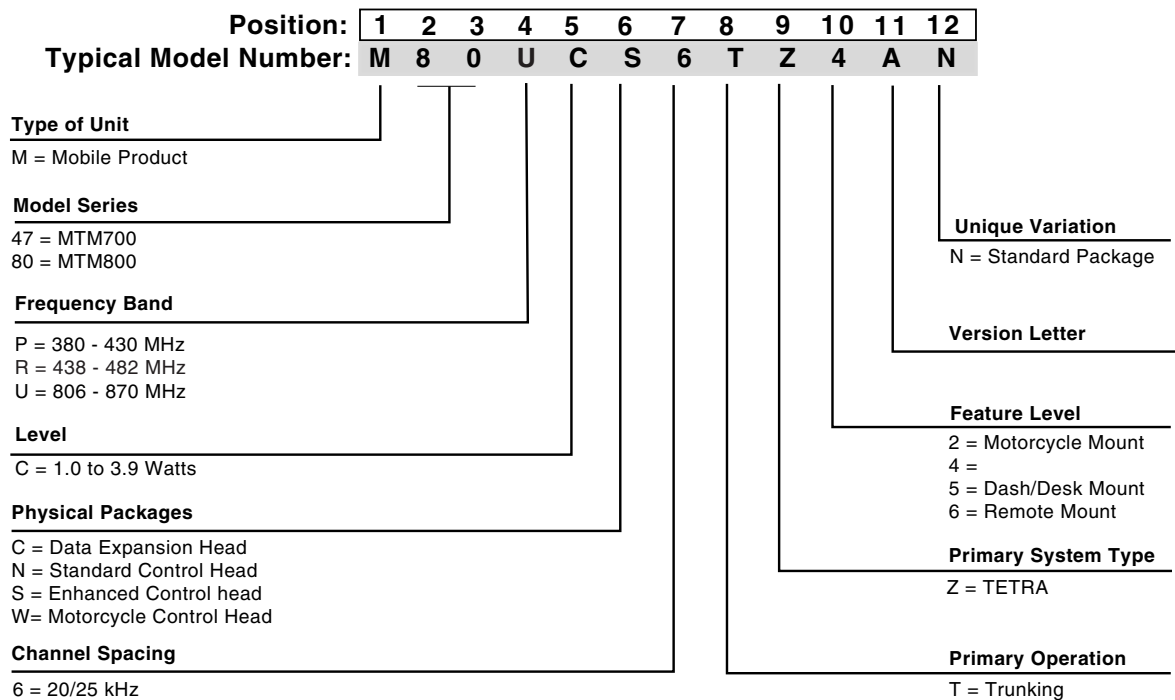

Model Specifications*

GENERAL		RECEIVER		TRANSMITTER	
ETSi:	ETS 300 394-1	Receiver Type:	Superheterodyne	Modulation Type:	$\pi/4$ DQPSK
Type Number:		Frequency Range:	851-870 MHz	RF Power:	
806-870 MHz	MT912M			TMO	3,16 W / 35 dBm
				DMO	3,16 W / 35 dBm
Temperature Range for Transceiver:		Channel Spacing:	25 kHz	Frequency Range TMO:	806-825 MHz
Operating	-30°C to +60°C				
Storage:	-40°C to +85°C	Sensitivity (3.5%) BER:	-112 dBm	Frequency Range DMO:	851-870 MHz
Power Supply:		Intermodulation:	-47 dBm		
Minimum:	10.8 Vdc	Blocking (50-100 kHz):	-40 dBm		
Nominal:	13.2 Vdc				
Maximum:	15.6 Vdc	Spurious Rejection:	-45 dBm	Frequency Stability:	
max. Current	approx. 3.5 A	Adjacent Channel Interference Ratio:	-45 dB	Locked to Base	+/-100 Hz
Dimensions (HxWxD) in mm:		Frequency Stability:		Not Locked to Base	+/- 1 kHz
Transceiver with		Locked to Base	+/-100 Hz	Spurious Emissions:	
Enhanced Control		Unlocked to Base	+/- 1 kHz	Conducted/ Radiated	- 36 dBm <=1GHz
Head, Dash Mount	60 x 185 x 175	Audio Rated (@4		- 30 dBm > 1GHz	
		Ohms):	10 W	Adjacent Channel Power (@ ± 25 kHz):	
Weight in grams:		For External Speaker:	5% Max.	806-870MHz	- 60 dBc
Transceiver with	1500	Distortion at Rated Audio:			
Enhanced Control					
Head, Dash Mount					

*) Technical information may be subject to change without further notice.

Model Descriptions**

Model	Description
M1	Dash Mount with Mobile Terminal (806-870MHz) with Direct Mount Control Head, Speaker, Microphone or Handset, Standard User Guide, and Installation Accessories.
M2	Desk Mount with Mobile Terminal (806-870MHz) with Direct Mount Control Head, Speaker, Microphone or Handset, Standard User Guide, and Installation Accessories.
M3	Remote Mount with Mobile Terminal (806-870MHz), with Expansion Control Head, User Guide Data, and Installation Accessories.
M4	Motorcycle Mount with Mobile Terminal (806-870MHz) with Motorcycle Control Head, Expansion Control Head, Speaker, Microphone, Motorcycle Cables, Motorcycle User Guide, and Installation Accessories.

***) Other combinations are not recommend or not possible.

CHAPTER 3 OVERVIEW

General

The MTM800 ENH is Motorola's latest and most advanced digital mobile TETRA radio. This radio generation is based on a new digital platform technology which takes care of the linear modulation type of radios to support the TETRA needs. It covers Trunk Mode Operation (TMO) as well as Direct Mode Operation (DMO) and among other new features it is supplied with extended code and operating memory capacity to support all new market requirements. The MTM800 ENH TETRA radio ensures a high audio quality.

To achieve high spectrum efficiency, the MTM800 ENH uses digital modulation technology and sophisticated voice-compression algorithm. The voice of the person speaking into the microphone is converted into a digital bit stream consisting of zeros (0) and ones (1). This stream is then modulated into a radio-frequency (RF) signal, which is transmitted over the air to another MTM800 ENH. The process is called digital modulation.

Digital Modulation Technique

The MTM800 ENH Mobile Terminal can be operated in dispatch mode. It uses two digital technologies: $\pi/4$ DQPSK and Time Division Multiple Access (TDMA).

$\pi/4$ DQPSK is a modulation technique that transmits information by altering the phase of the radio frequency (RF) signal. Data is converted into complex symbols, which alter the RF signal and transmit the information. When the signal is received, the change in phase is converted back into symbols and then into the original data.

The Tetra system can accommodate 4-voice channels in the standard 25 KHz channel as used in the two-way radio.

Time Division Multiple Access (TDMA) is used to allocate portions of the RF signal by dividing time into four slots, one for each unit.

Time allocation enables each unit to transmit its voice information without interference from other transmitting units. Transmission from a unit or base station is accommodated in time-slot lengths of 15 milliseconds and frame lengths of 60 milliseconds. The TDMA technique requires sophisticated algorithms and a digital signal processor (DSP) to perform voice compression/decompression and RF modulation/demodulation.

Voice Compression Technology

Voice is converted into a digital bit stream by sampling the voice at high rate and converting the samples into numbers, which are represented by bits.

Voice compression reduces the number of bits per second while maintaining the voice at an acceptable quality level. The Tetra system uses a coding technique called ACELP (Algebraic Code Excited Linear Prediction). The compressed voice-data bits modulate the RF signal.

THIS PAGE INTENTIONALLY LEFT BLANK

CHAPTER 4

THEORY OF OPERATION

Section Introduction

This section provides a block diagram overview of the main Digital/RF Board. This is supplemented by the detailed block diagram and detailed circuit description.

This Chapter contains the following sections:

4.1 Transceiver 806-870MHz

4.2 Control Heads

THIS PAGE INTENTIONALLY LEFT BLANK

CHAPTER 4.1

THEORY OF OPERATION

Block Diagram and Overview

The main Digital/RF block contains the following five sections:

- Receiver Section
- Transmitter Section
- Frequency Generating Section (Synthesizer)
- Controller Section
- GPS sub module

An overview and a detailed description of these sections is provided in the following paragraphs.

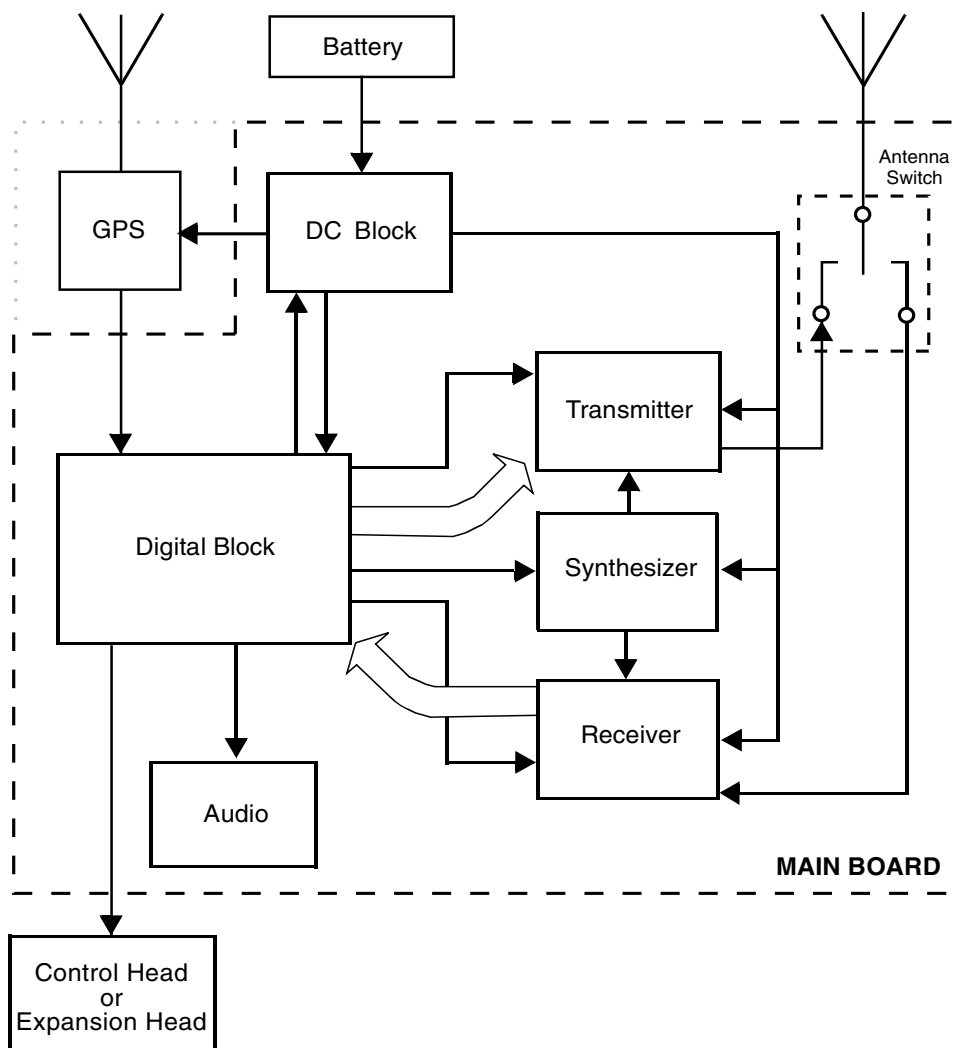

Figure 1 General Block Diagram

Receiver Section

The receiver section includes the following main components:

- Antenna Switch
- AGC_0 Attenuator
- Front End Pre-selector Filter
- Low Noise Amplifier (LNA)
- AGC_1 Attenuator
- Second Pre-selector Filter
- Mixer
- IF Filter
- IF Amplifier
- AGC_2 Attenuator and Buffer
- IF Digitizing Subsystem

The Receiver Path implements an Automatic Gain Control (AGC), which is required to maintain good receiver linearity over a wide range of incoming signal levels and prevents clipping of high level signals.

The IF Digitizing Subsystem performs the following functions:

- Carries out amplification and down conversion of the signal into the second IF.
- Performs IF AGC.
- Converts the second IF analog signal into baseband digital I & Q format.
- Transmits the I & Q baseband data to the DSP for further processing.
- Synthesizes the second LO frequency.
- Synthesizes the Sigma-Delta clock
- Calculates the received signal strength.

Transmitter Section

The transmitter incorporates cartesian feedback circuitry to enhance transmitter linearity to reduce power splatter into adjacent channels. The transmitter circuitry comprises the following components:

- Modulation digital to analog conversion, performed by:
Analog-to-Digital / Digital-to-Analog IC (ADDAG),
- Modulation up-converter, performed by:
Low Noise Offset Direct Conversion Transmitter integrated circuit (JAVELIN),
- Balun and Attenuator,
- Linear class AB Power Amplifier (PA),
- Directional coupler,
- Isolator (depends on terminal model)
- Antenna switch, and
- Harmonic filter.

The transmitter linearization feedback signal is taken from the forward power port of the directional coupler, attenuated, and passed to the RF feedback port of the JAVELIN integrated circuit.

Controller Section

This section includes the Patriot Bravo, which controls the transmit, receive and synthesize operations of the integrated circuits located in the RF section. Within the Patriot Bravo are the DSP and the serial interfaces.

The controller section contains the following:

- Voltage regulators
- Power On/Off circuitry
- Patriot Bravo
- Host memories (FLASH and SRAM)
- Serial peripheral interface (SPI)
- RS232, USB, SB9600, SBEP serial interfaces
- RX and TX path multiplexer
- Programmable potentiometer
- CODEC
- Audio power amplifier (PA)

Frequency Generating Section

The frequency generating section comprises the following components:

- Reference Oscillator - TCXO
- Main Synthesizer - consists of the Main Voltage Controlled Oscillator (VCO) and Low Voltage Fractional-N integrated circuit (LVFracN). In receive mode, the main synthesizer provides the local oscillator injection to the receiver first mixer. In transmit mode, this synthesizer provides the frequency reference for the transmit frequency translation loop.
- Transmit frequency translation loop. Consists of the transmit Voltage Controlled Oscillator (VCO) and ESCORT Near Unity Divider (NUD) Phase Locked Loop IC.

GPS Section

The GPS Sub module includes the following main components:

- Front End Filter
- LNA matching network
- The Phoenix GPS Acquisition Module (PGAM)
- 26MHz Reference TCXO
- Power supply for PGAM IC
- 5V (20mA) Phantom Power Supply for external LNA

Block Diagrams Descriptions

The block diagrams descriptions cover Receiver Path, Transmitter Path, Frequency Generation Section, and Controller Section.

Receiver Path

The received signal (see figure below) from the antenna is directed by the Antenna Switch to the Front End Pre-selector Filter.

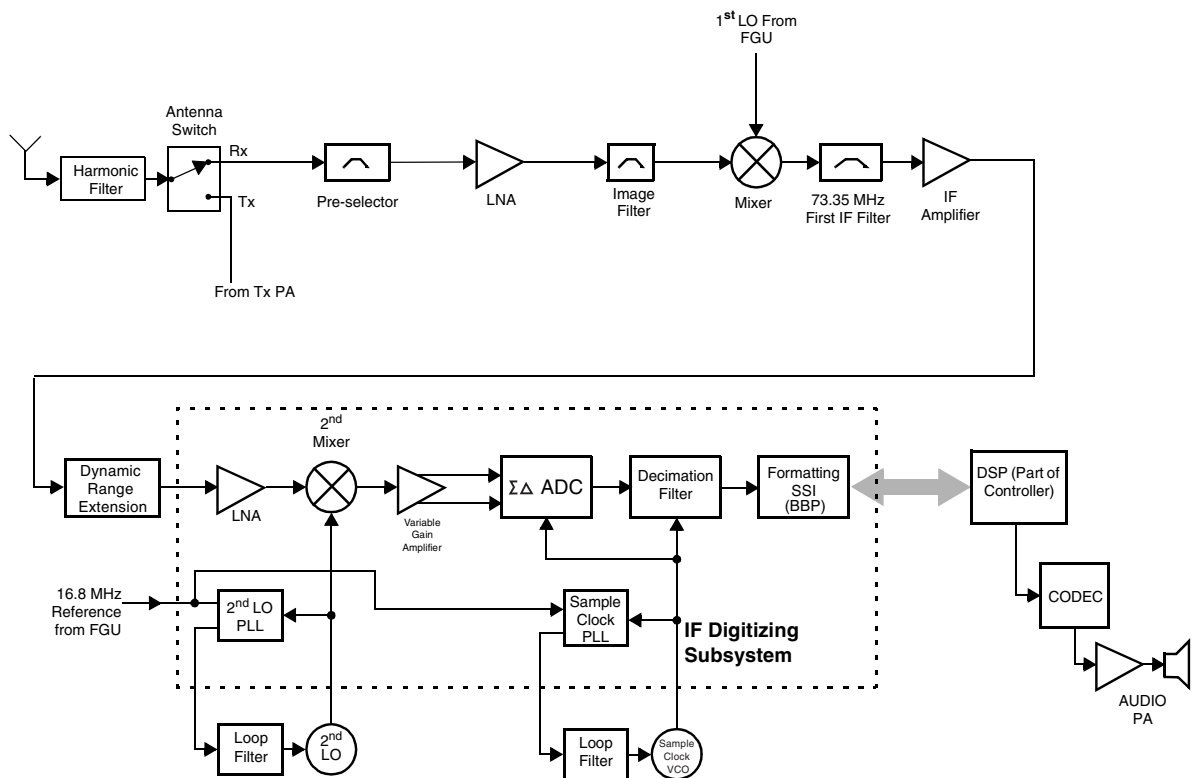

Figure 2 Receive Path Block Diagram

The receive pre-selector filter performs the following functions:

- passes frequencies in the 851 – 870 MHz receive frequency range, and
- blocks unwanted spurious frequencies like half IF and image frequencies.

The signal is mixed with the low side injection local oscillator signal to create the first IF at 73.35 MHz. The IF signal is filtered by the crystal filter, amplified by the IF amplifier, and sent to the IF Digitizing IC.

The IF Digitizing Subsystem performs the following functions:

- down conversion to the second IF at 2.25 MHz,
- perform a bandpass sigma-delta analog-to-digital conversion of the second IF signal into in-phase (I) and quadrature (Q) digital signals.

- Formats the I and Q data streams into a serial bit stream, which is sent for further processing to the Digital Signal Processor (DSP) (part of the micro controller) over the Synchronous Serial Interface (SSI) data link.

The DSP performs the following functions:

- Base band filtering,
- Synchronisation
- Demodulation
- Forward Error Correction (FEC)
- other correction algorithms for overcoming channel errors, and
- the decoder procedure for digital speech data decompression.

Transmitter Path

When the terminal is transmitting (see figure below), microphone audio is sent to the CODEC, which performs analog-to-digital conversion and routes the digital signal to the DSP. The DSP performs the following functions:

- coding,
- error correction, and
- generation of the baseband modulation waveform.

From the DSP, baseband digital 'I' and 'Q' modulation waveform samples are sent to the ADDAG IC, where the digital data is converted into baseband analog 'I' and 'Q' waveforms and filtered.

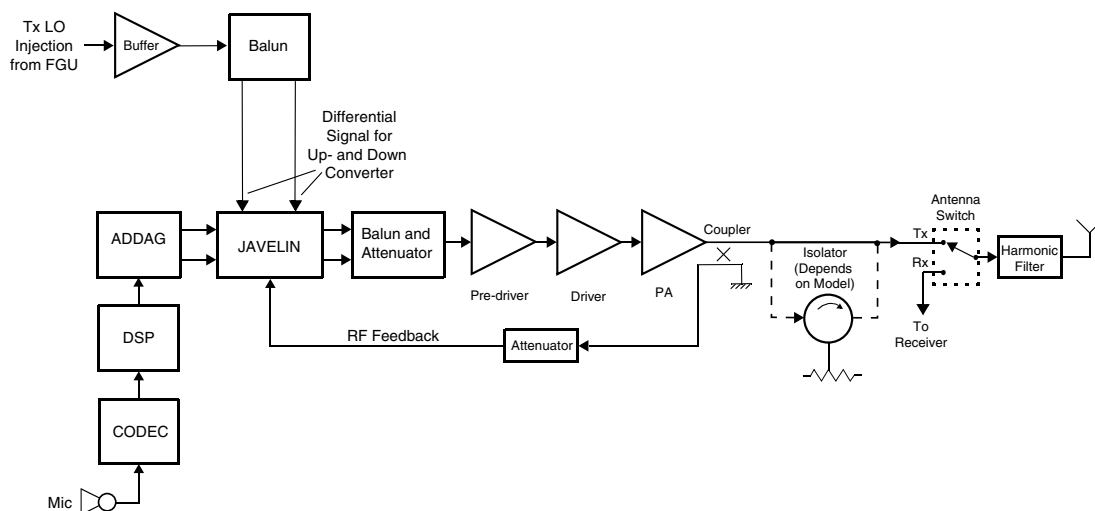

Figure 3 Transmit Path Block Diagram

The analog modulation signal is passed on to the JAVELIN where it is up-converted to the transmitter operating frequency. The modulated RF output signal from the JAVELIN is converted from differential to single-ended by a balun, and passed to the attenuator, pre-driver IC, driver transistor, power amplifier transistor, directional coupler, and isolator (depends on terminal model), from where it is routed to the antenna via the antenna switch and harmonic filter. An RF feedback signal is taken from the directional RF coupler and fed back to the JAVELIN for transmitter power control and linearization.

Frequency Generating Section

The frequency generating section comprises the following components (see figure below):

- 16.8 MHz TCXO Reference Oscillator.
- Main Synthesizer - consists of the Main Voltage Controlled Oscillator (VCO) and Low Voltage Fractional-N (LVFRACN) integrated circuit PLL. In receive mode, the main synthesizer provides the local oscillator injection to the receiver first mixer. In transmit mode, this synthesizer provides the frequency reference for the transmit frequency translation loop.
- Transmit frequency translation loop - consists of the transmit Voltage Controlled Oscillator (VCO) and ESCORT Near Unity Divider (NUD) Phase Locked Loop IC.

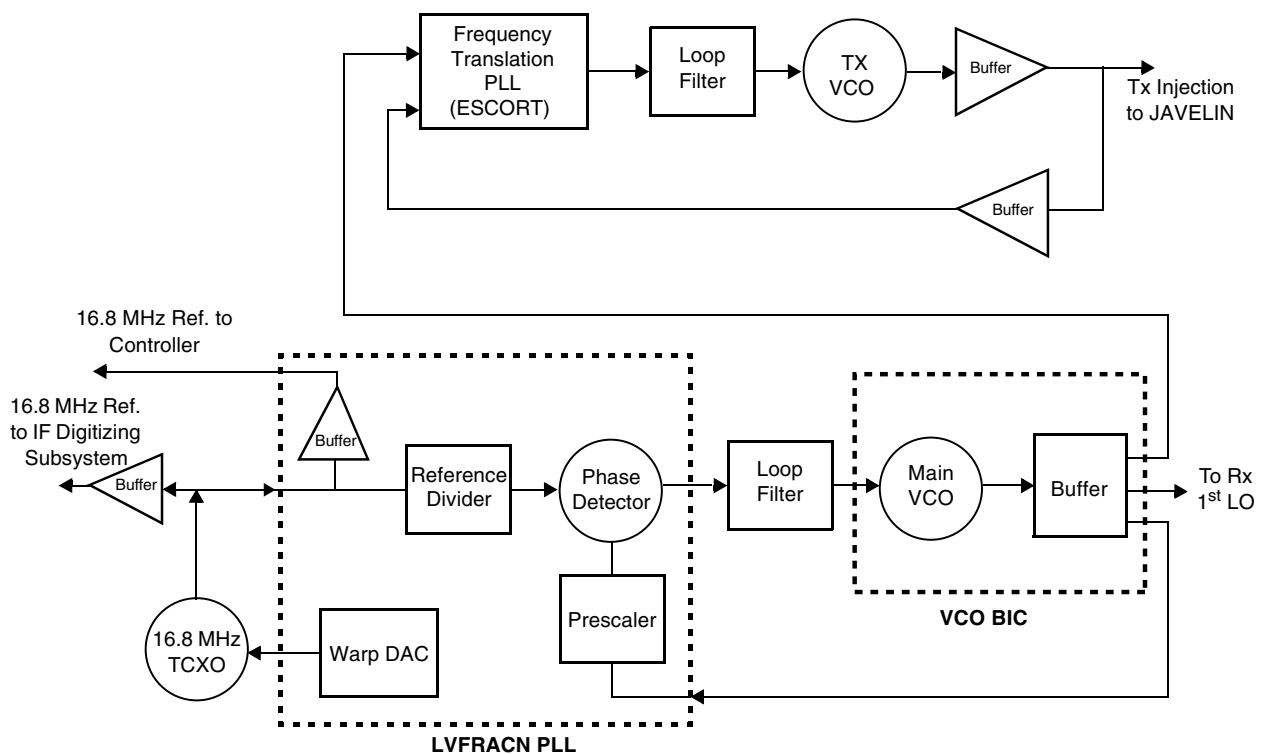

Figure 4 Frequency Generating - Block Diagram

The reference oscillator –TCXO is a temperature compensated crystal oscillator producing an accurate and stable 16.8 MHz master clock, from which all other clocks in the terminal are derived. It provides the reference frequency for the following components:

- the main frequency synthesizer,
- the IF Digitizing Subsystem,
- the ADDAG, and
- the micro controller

Its operating frequency is fine tuned by means of a warp voltage signal which is controlled by the controller and generated by the LVFRACN IC

Main Synthesizer

The Main Synthesizer consists of the main VCO and LVFRACN PLL IC. The main synthesizer provides the LO signal to the first mixer for down-converting the received signal to the 73.35 MHz first IF frequency and in transmit mode provides the reference frequency for the ESCORT frequency translation loop.

Transmit frequency translation loop

The transmitter frequency translation loop consists of the transmit VCO and ESCORT near unity divider PLL IC. This subsystem generates the carrier frequency injection signal for the JAVELIN.

Controller Section

The controller section contains the Patriot Bravo dual core (DSP / RISC) processor and its external memory, the TX and RX audio processing, the serial interfaces and I/O circuitry.

The Patriot Bravo controls the receive / transmit frequencies, power levels, control head display and keypad, serial interfaces, accessories, MMI, and other terminal functions. This microprocessor can be operated through the RS232 interface by a personal computer to program the FLASH.

The TX audio circuitry selects between the different microphone inputs, controls the TX audio level and converts the analog audio signal to a digital format.

The RX audio circuitry converts the received signal from digital format to an analog audio signal, performs volume control and amplifies the signal to speaker level.

The DSP performs signalling, and voice encoding and decoding.

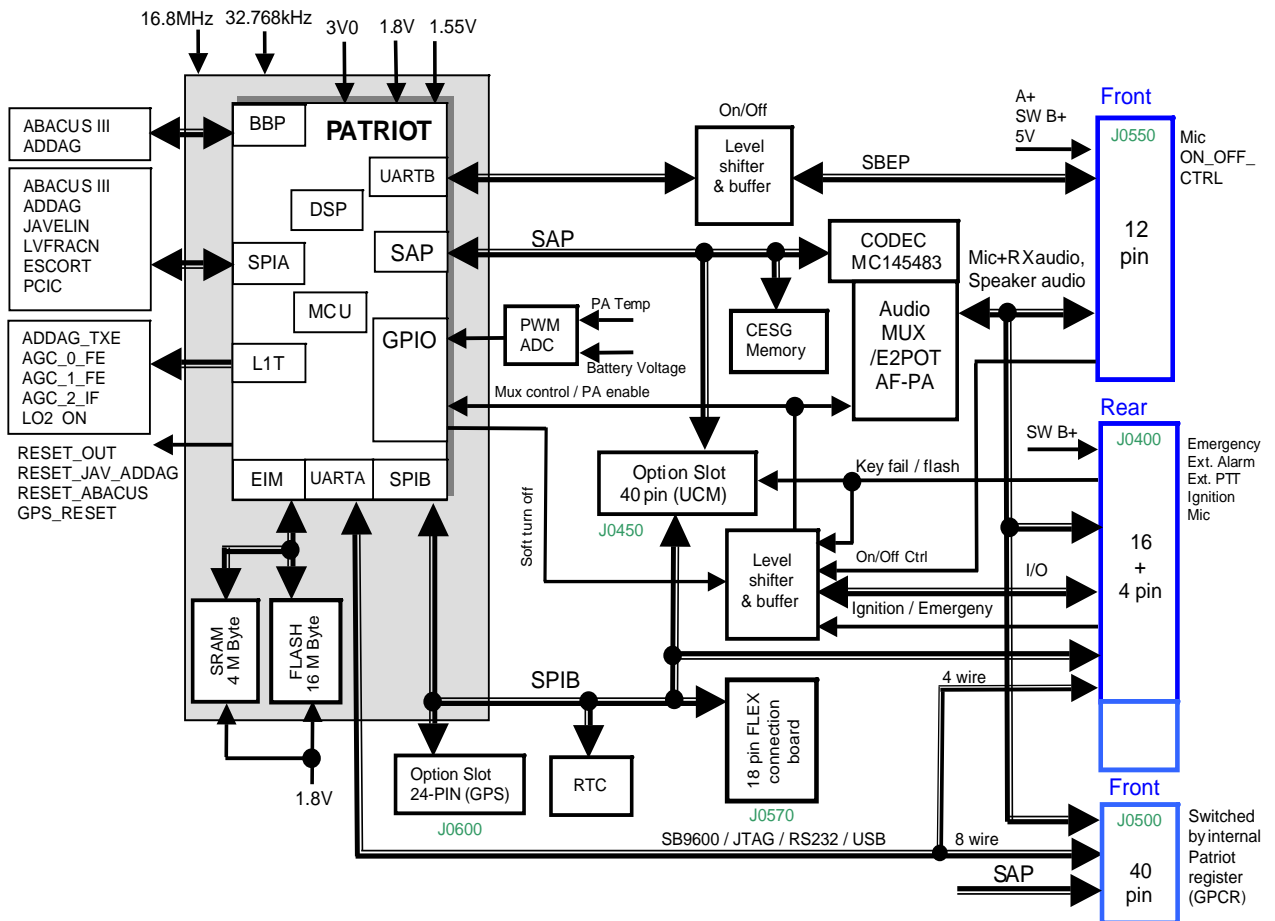

Figure 5 Controller Block Diagram

Detailed Circuit Description

Receiver Path, Detailed Circuit Description

For the Receive Path Block Diagram see Figure 2.

Antenna Switch

The signal coming from the antenna is routed to the receiver section via the harmonic filter, which is comprised of L5461, L5462, C5461, C5462, C5464 and C5466. The signal continues to flow through quarter wave transformer L5452 and C5555 to the RX section toward pre-selector filter. The limiter (D5002) function is to prevent entrance of signals with power higher than 30dBm, which may damage the receiver front-end.

Pre Selector Filter

The signal is passed to the first pre-selector filter (FL5002) and from there routed to Low Noise Amplifier (LNA) (U5003). The first pre-selector filter attenuates incoming spurious RF frequencies, especially the image frequency

LNA

The Low noise amplifier (LNA) U5003 amplifies the incoming received signal. It maintains a large gain and small Noise Figure. When LNA "enable" (pin 3, VPD) receives a supply of 1.9 V from DC switch (Q5002), the amplifier is enabled. From the LNA the signal passes to the second pre-selector filter (FL5001).

Second Pre-selector

The second pre-selector filter (FL5001) provides further attenuation of incoming image and half-IF spurious response signals, as well as noise at the image frequency that may be generated by the LNA. From the output of the second pre-selector filter the received signal is sent to the RF input port of the first mixer.

Mixer

Mixer U5002 down-converts the incoming RF signal to the 73.35 MHz first IF, utilizing a first local oscillator signal tuned 73.35 MHz below the desired receiver operating frequency. An impedance matching network (L5012, C5037, C5036, L5201, C5203, L5011, L5018) is placed between the mixer output and IF filter U5201.

IF Filter, Amplifier, Dynamic Range Extension

The IF signal is routed via IF filter (FL5201) to IF amplifier Q5201. From there it is routed to the Dynamic Range Extension circuitry which comprises Q5101, its bias components, and D5121. This circuitry is required to maintain good receiver linearity over a wide range of incoming signal levels,

and prevent clipping of high level signals. This circuit avoids the use of fixed switchable attenuators typically used in Automatic Gain Control (AGC) circuits.

IF Digitizing Subsystem

The IF Digitizing Subsystem is comprised of U5101. Here the IF signal is amplified and then mixed with an internally generated 2nd LO signal to produce the second IF signal.

The 2nd IF signal is first processed by a variable gain amplifier and then converted to in-phase and quadrature (I and Q) digital data samples by means of a bandpass sigma-delta analog-to-digital converter.

The I and Q digital signals are formatted into a single serial bit stream and sent for further processing to the Digital Signal Processor (DSP) (part of micro-processor) over the Synchronous Serial Interface (SSI) data link.

An internal AGC circuit controls the gain of the variable gain amplifier (VGA) to ensure that the maximum signal level into the ADC does not exceed a fixed analog ADC clip level and the rms output level of the ADC is maintained at an established reference level.

An internal phase locked loop control circuit controls the frequency of voltage controlled oscillator Q5180 which generates the 71.1 MHz 2nd LO injection frequency.

An internal phase locked loop control circuit controls the frequency of voltage controlled oscillator Q5190 which generates the 18MHz sample clock frequency utilized by the ADC and decimation filters.

Both phase locked loops derive their frequency reference from the buffered 16.8 MHz TCXO master clock.

Transmitter Path, Detailed Circuit Description

For the Transmit Path Block Diagram see Figure 3.

ADDAG

The Analog to Digital/Digital to Analog IC U5810 (ADDAG) receives the modulation waveform as serial data transmitted by the DSP at a 48 kbps rate to the SSI port (ball C7, STD). Data is transmitted as a 16-bit 'I' word followed by a 16-bit 'Q' word. The ADDAG provides a serial clock of 2.4MHz to the DSP (ball B6, SCK) and sends a frame sync signal (ball B7, SFS) at the beginning of every 'I' word transmission, to instruct the DSP to send data.

In the ADDAG, the received serial I & Q words are converted into parallel I & Q words, and transferred to an interpolation filter. The interpolation filter increases the sampling rate to reduce in-band quantization noise, as well as to reduce image at multiples of the input data. The interpolated samples are rounded to 8 bits, and run through 8-bit D/A converters.

The D/A converters take the digital I & Q words and convert them into analog signals, which are filtered and amplified. The output is comprised of two separate low-level differential signals, I & Q (ball E2, OUT1; ball E1, OUT1B; ball D1, OUTQ; ball C1, OUTQB). The output signals are routed to the JAVELIN IC for up conversion to the transmitter operating frequency. They are also available on R5841, R5842, R5843 and R5844. The ADDAG sends a 2.4MHz low-level differential reference clock signal (ball C2, TCLK; ball B1, TCLKB) to the JAVELIN.

It also sends a differential signal (ball A1, Tslot; ball B2, TslotB) that marks the beginning and end of each transmission slot (whenever a TXE signal {ball B5 TXE} is received from the DSP). After receiving the Tslot signal, the JAVELIN toggles the ASW line (ball F2, ASW) which signals the ADDAG to set VCNT0 signal LOW (ball F2, VCNT0) which enables the Antenna Switch during the transmit slot. The ADDAG starts to receive data from DSP after TXE signal (ball B5, TXE).

Tx LO

The Tx LO signal path processes the signal generated by the Transmit Frequency Translation Loop (part of the FGU), which determines the operating frequency of the transmitter. The input signal is amplified by Q5801, and passed to the Balun T5801 which provides the differential signal to the JAVELIN LO input (balls H5, VCO1 and H6, VCO1B). Internally to the JAVELIN the signal is routed to the feedback down conversion circuitry and to a 90 degree phase shifter, that provides the I and Q vectors for up conversion.

JAVELIN

The Low Noise Offset Direct Conversion Transmitter (JAVELIN) U5809 performs the following tasks:

- up converts the baseband I and Q modulation waveform to the transmitter operating frequency,
- controls power output, and
- cancels power amplifier distortion products created by non-linearities in the RF power amplifier output stage.

The differential base-band signals from the ADDAG are input into the JAVELIN on balls C1, B1, C3, B2 (BINQB, BINQ, BINIB and BINI). The baseband I and Q waveforms are passed through a

variable attenuator and then they are summed with the down-converted I & Q feedback signal. The base-band signal is then amplified and sent to the up-mixer. The up-mixer consists of two mixers, one for the I channel and the other for the Q channel.

The split I & Q LO signal is mixed with the base-band I & Q signals to produce an I and Q modulated signal at RF frequency. The signal is then output differentially on balls E8 and D8 (RFOUT2B, RFOUT2), where the differential RF signal is converted to a single-ended unbalanced output by means of BALUN T5802. The output signal from the BALUN is applied to the RF Power Amplifier.

RF Power Amplifier

The RF Power Amplifier consists of attenuator R5413, R5414, R5415, pre-driver IC U5401, driver transistor Q5421, and output transistor Q5431. The overall RF gain of the power amplifier string is fine tuned by the BIAS1 voltage from the controller, which is applied to VCNTL pin 1 on pre-driver U5401. The BIAS1 signal is buffered by amplifier Q5501. The operating bias point of driver Q5421 and PA Q5431 is set by BIAS2 and BIAS3 respectively, buffered by Q5521 and Q5542.

Directional Coupler and RF Feedback Path

A directional coupler exists at the RF PA output, and is used to pass the signal to the Antenna Switch via the isolator FL 5451 and to sample the signal thus providing the necessary feedback for the linearization and feedback correction. The sampled signal is routed via attenuator R5453, R5454, R5455 and the BALUN L5812 to the JAVELIN (ball D1, RFIN, ball E1, RFINB). Internally to the JAVELIN, the RF feedback signal is mixed down to base-band in a quadrature down mixer, and summed with the base-band input signal to provide cancellation of modulation distortion generated in the power amplifier.

Antenna Switch

The RF signal from the Directional Coupler is applied to PIN diode D5451. This PIN diode is turned on during the transmission time slot, to route the transmitter output signal to the harmonic filter (C5455-C5457, C5461-C6467, L5461, and L5462), and from there on to the antenna connector. During the transmit time slot, pin diode D5551 is also turned on, preventing power from the transmitter from reaching the receiver LNA. During receive time slots, PIN diodes D5451 and D5551 are OFF, allowing receive signals to pass from the antenna connector through the harmonic filter, through L5452, and on to the receiver input preselector.

Harmonic Filter

From the antenna switch the signal is routed to the harmonic filter, consisting of C5455-C5457, C5461-6467, L5461, and L5462. The filter is required to attenuate transmitter harmonics during transmit mode, and leakage of local oscillator harmonics during receive mode.

Frequency Generating Section Detailed Circuit Description

For the Frequency Generating Section Block Diagram see Figure 4.

This section describes the generating circuits that supply all the required frequencies for the required transmitter and receiver functions. These circuits are described as follows:

- 16.8 MHz Reference Oscillator - TCXO.
- Main VCO and Main Synthesizer.
- Transmit frequency translation loop.

Reference Oscillator - TCXO

16.8 MHz TCXO (Y5363) is a temperature compensated crystal oscillator producing an accurate and stable 16.8 MHz master clock to the terminal RF circuits. Its operating frequency is fine tuned by means of a warp voltage signal generated by the LVFRACN IC (U5331, pin 25). On terminal power-up, an initial warp voltage setting is programmed into the LVFRACN IC by the microprocessor via the SPI bus, using a stored value programmed into the terminal codeplug during factory tuning.

While the receiver is registered to the terminal system, an automatic frequency control algorithm is executed by the microprocessor, to fine tune the LVFRACN warp voltage to bring the TCXO frequency into alignment with the terminal system frequency standard.

The output signal at pin 3 of the TCXO is passed to LVFRACN IC U5331, where it is used as a reference for the main frequency synthesizer. The TCXO output is also buffered by Q5351, and passed to other terminal circuits via REF16_8_OSC. The LVFRACN IC buffers the 16.8 MHz reference, and provides it at FREFOUT (pin 41) for use by other terminal circuits.

Main VCO and Main Synthesizer

The synthesizer components are LVFRACN, Loop Filter, VCO and VCO Buffer IC (VCO BIC). It produces the receiver first LO signal, as well as serving as the reference for the transmit frequency translation loop.

The operating frequency of Voltage Controlled Oscillator (VCO) with active element Q5712 is determined by resonator W5701, in conjunction with C5735, C5737, C5738, C5736, L5733, and varactors D5731-5734. The operating frequency of the oscillator is varied by means of varactor tuning voltage VCTRL, supplied by the LVFRACN U5331 IOOUT signal (pin 43), and filtered by loop filter components C5303, R5304, C5305, R5303, R5302, and C5301. The RF output of the VCO is buffered by U5701

U5701 pin 12 provides a sample of the VCO output to the LVFRACN prescaler input (pin 32), where the signal is divided down to a lower comparison frequency by means of a programmable frequency divider. The divided down VCO signal is compared to a signal derived from the 16.8 MHz reference clock to generate an error signal (IOOUT) which is filtered by the loop filter and tunes the VCO to the programmed operating frequency.

A LOCK_FN signal is available at LVFRACN pin 4 to provide feedback to the microprocessor that the synthesizer has successfully locked to the programmed frequency. The "RX_OUT" signal from buffer U5701 pin 8 is amplified by Q5701, and supplied to the first mixer LO port.

The "TX_OUT" signal from buffer U5701 pin 10 provides the frequency reference for the Transmit Frequency Translation Loop.

Transmit Frequency Translation Loop

The Transmit Frequency Translation Loop comprises the following components:

- transmit Voltage Controlled Oscillator (VCO) and
- the ESCORT Near Unity Divider (NUD) Phase Locked Loop IC.

The operating frequency of Voltage Controlled Oscillator with active element Q5601 is determined by resonator W5601 in conjunction with C5603, C5604, C5606, C5607, L5603, and varactors D5601-5604. The operating frequency of the oscillator is varied by means of a tuning voltage applied to the varactors.

The translation loop works as follows:

- A sample of the VCO operating frequency is buffered by Q5631 and applied to the FREQA input of the NUD IC U5702 pin 16 , where it is divided by a programmable divider set to 1.0625, and phase compared to a reference frequency supplied to U5702 FREQB pin 9 from the main synthesizer
- The result of this comparison is a VCO tuning signal, buffered by charge pump transistors Q5604, Q5605, and Q5653, filtered by loop filter components C5653, R5652, C5654, C5655, and L5607 and applied to the VCO varactors.
- The action of the feedback loop is to maintain the operating frequency of the Transmit VCO at 1.0625 times the programmed operating frequency of the main synthesizer.
- The loop bandwidth of the transmit frequency translation loop is set to a high value in order for the corrective feedback action of the loop to suppress re-modulation of the VCO as a result of leakage of the modulated transmitter signal from the transmitter Power Amplifier output back into the VCO.

Controller Section

For the Controller Section Block Diagram see Figure 5.

This section describes the related circuits as follows:

- DC Power Distribution and RESET
- Microprocessor and Host Memories
- SPI
- RS232/USB
- Terminal Audio System
- RTC
- GPS
- SIM card connectivity
- GPIOs

DC Power Distribution

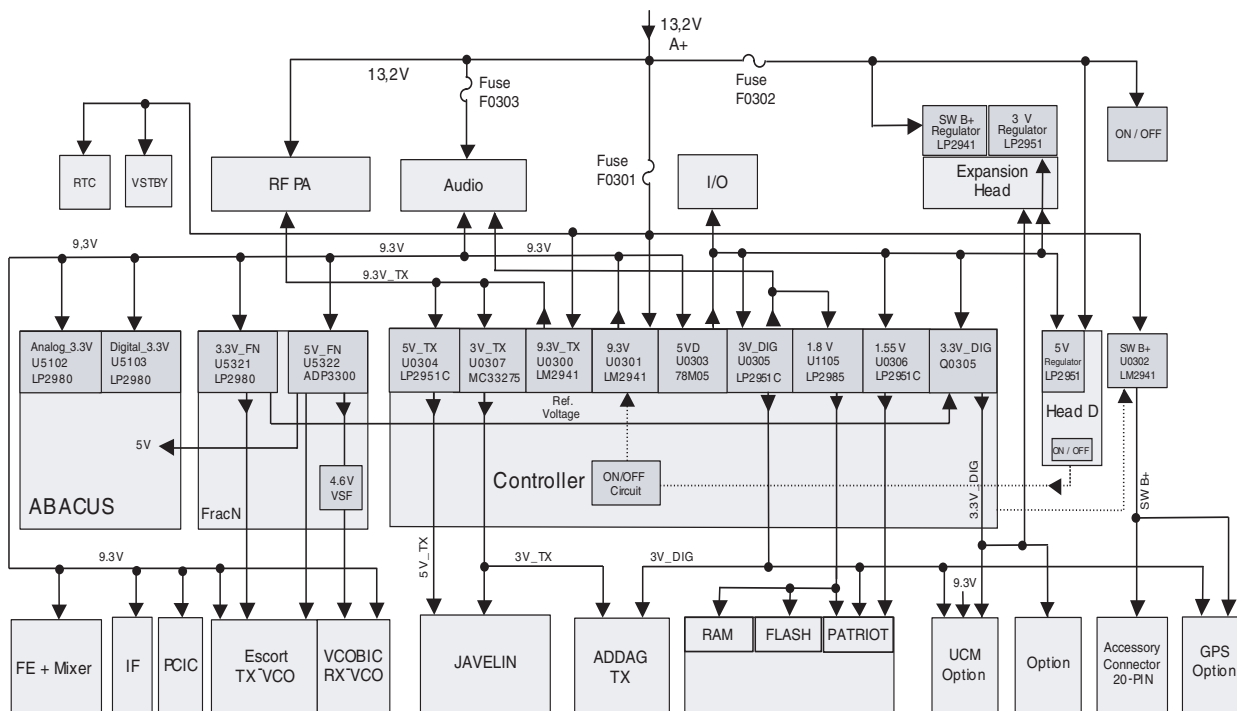

Figure 6 DC Power Distribution Diagram

DC Power Input

The DC power of nominal 13.2 volts enters the terminal at connector J0301. Diode VR0300 acts as protection against transients and wrong polarity of the supply voltage. The supply voltage is fed directly to the RF PA, through the 3A fuse F0303 to the audio circuitry, through F0302 to the

expansion head and control head, and through the 4A PCB fuse (F0301) to regulators U0300, U0301, U0302, and the ON/OFF and VSTBY circuitry. The fuses protect the board from over current in case of a short on the connector pins or circuit failure.

9V3 Linear Regulator U0301

Regulator U0301 is connected to the 13.2 volts supply voltage via PCB fuse. The output of this regulator is controlled by the ON/OFF circuitry. When any of the signals RTC_ON_SW, ON_OFF_CONTROL_SV, SOFT_TURN_OFF, IGNITION is at high level or EMERGENCY is at low level the regulator is switched on via transistors Q0302, Q0301, Q0303. In addition, regulators U0300 and U0302 are also switched on by the same signal. The output voltage of U0301 is set to 9.3 volts with resistors R0307 and R0308.

9V3_TX Linear Regulator U0300

Regulator U0300 is connected to the 13.2 volts supply voltage via PCB fuse. The output of this regulator is controlled by the ON/OFF circuitry. When any of the signals RTC_ON_SW, ON_OFF_CONTROL_SV, SOFT_TURN_OFF, IGNITION is at high level or EMERGENCY is at low level the regulator is switched on via transistors Q0302, Q0301, Q0303. The output voltage of U0300 is set to 9.3 volts with resistors R0305 and R0306.

SW B+ Current Limit Regulator U0302

Regulator U0302 is connected to the 13.2 volts supply voltage via PCB fuse. The output of this regulator is controlled by the ON/OFF circuitry. When any of the signals RTC_ON_SW, ON_OFF_CONTROL_SV, SOFT_TURN_OFF, IGNITION is at high level or EMERGENCY is at low level the regulator is switched on via transistors Q0302, Q0301, Q0303. The output voltage of U0302 is set far above the maximum possible input voltage with resistors R0303 and R0304 so that this regulator acts as a current limiter for the EXT_SWB+ voltage on the 20 pin accessory connector.

5VD Linear Regulator U0303

Regulator U0303 gets its input voltage from the 9.3 volt regulator U0301. The output voltage 5VD is fixed to 5 volts and is the input voltage for the regulators U0305 and U0306. The voltage 5VD is also fed to the enhanced control head.

5V_FN Linear Regulator U5322

Regulator U5322 gets its input voltage from the 9.3 volt regulator U0301. The output voltage 5V_FN is fixed to 5 volts and is mainly used in the frequency generating unit (FGU).

3V3_FN Linear Regulator U5321

Regulator U5321 gets its input voltage from the 9.3 volt regulator U0301. The output voltage 3V3_FN is fixed to 3.3 volts and is mainly used in the frequency generating unit (FGU).

Analog_3V3 Linear Regulator U5102

Regulator U5102 gets its input voltage from the 9.3 volt regulator U0301. The output voltage ANALOG_3V3 is fixed to 3.3 volts and is mainly used in the receiver section.

Digital_3V3 Linear Regulator U5103

Regulator U5103 gets its input voltage from the 9.3 volt regulator U0301. The output voltage DIGITAL_3V3 is fixed to 3.3 volts and is mainly used in the receiver section.

3V_TX Linear Regulator U0307

Regulator U0307 gets its input voltage from the 9.3 volt regulator U0300. The output voltage 3V_TX is fixed to 3 volts and is used in the transmitter TX_LOW section to supply the ADDAG and JAVELIN IC.

5V_TX Linear Regulator U0304

Regulator U0304 gets its input voltage from the 9.3 volt regulator U0300. The output voltage 5V_TX is fixed to 5 volts and is mainly used in the transmitter section.

3V3_DIG Voltage Follower Q0305

Transistor Q0305 is configured as voltage follower and gets its input voltage from the 5 volt regulator U0303. The output voltage 3V3_DIG is set to 3.3 volts by the reference voltage 3V3_FN from U5321. Diode D0303 compensates the base to emitter voltage drop of Q0305. The voltage is used as supply voltage for modules connected to J0570.

3V_DIG Linear Regulator U0305

Regulator U0305 gets its input voltage from the 5 volt regulator U0303. The output voltage is fixed to 3 volts and is mainly used in the controller section to supply the I/O voltage.

1.55 V Linear Regulator U0306

Regulator U0306 gets its input voltage from the 5 volt regulator U0303. The output voltage is set to 1.55 volts with resistors R0318 and R0319 and is used in the controller section for supplying the Patriot Bravo core.

1.8 V Linear Regulator U1105

Regulator U1105 gets its input voltage from the 3 volt regulator U0305. The output voltage is 1.8 volts and is used in the controller section for supplying the address and data bus voltage of the patriot Bravo and for supplying the Flash and RAM memory.

4.6V VSF Voltage

The fractional N synthesizer U5331 creates the 4.6 volts super filter voltage (VSF). This voltage is used for the main VCO.

RESET

The open drain Error outputs of the regulators U0304 (5V_TX), U0305 (3V_DIG), U0306 (1V55) as well as the 2.8V voltage sense IC U0308 are connected together to create the LV_DETECT signal which is the RESET_IN signal of Patriot Bravo. Furthermore the circuitry Q0341, Q0342, R0341, R0342, R0343 generates a reset when a programming cable is disconnected from the terminal. The reset sources share the pull up resistor R0344

Microprocessor

The Patriot Bravo dual core (DSP / RISC) processor (U1100, block 1 to 5) controls the terminal hardware, communicates via various interfaces with external equipment or accessories and performs digital signal processing. Beside its internal memory the Patriot Bravo uses the FLASH Memory and the SRAM also located near to the controller. The Patriot Bravo exchanges digitized audio data with the CODEC via its Serial Audio Port (SAP). The Patriot Bravo sends digital baseband data to the ADDAG and receives digital baseband data from the ABACUS via its Baseband Port (BBP). To communicate with the RF IC's the Patriot Bravo uses one of its Queued

Serial Peripheral Interfaces - the (QSPIA). A second interface, QSPIB, is used for communication with external equipment or accessories. The Patriot Bravo has 2 universal asynchronous receiver / transmitter ports (UARTA and UARTB) for communication with external equipment e.g. a control head or a control terminal (PC). UARTA communicates via SB9600, RS232 or USB protocol and UARTB communicates via SBEP protocol.

Host Memories

Flash Memory

The 16MByte FLASH Memory (U1102) located near to the micro-controller contains the terminal's Application Software and the Terminal Code Plug. The Code Plug stores customer related information and terminal parameters. The Patriot Bravo accesses the data via a 24 bit wide address bus (A0-A23), a 16 bit wide data bus (DQ0-DQ15), and 8 control lines (EN_CE, EN_OE, EN_WE, ADV, BURSTCLK, WP, VPP and RESET). When the FLASH Memory has been replaced or the software needs to be upgraded, the new Code Plug and application software must be programmed into the FLASH Memory.

SRAM Memory

The 4MByte SRAM (U1103) located near to the micro controller stores data that can change very frequently, and which is generated and stored by the Application Software during its normal operation. The information is lost when the terminal is turned off. The Patriot Bravo accesses the data via a 21 bit wide address bus (A0-A20), a 16 bit wide data bus (IO1-IO16), and 6 control lines (CS1, CS2, EN_OE, EN_WE, LB, UB).

EEPROM

On the terminal mainboard, an additional 128 kbit serial memory is connected to the SAP interface of the Patriot Bravo. This EEPROM holds encryption keys and is accessed by the DSP.

Serial Peripheral Interface (SPI)

The Patriot Bravo features two SPI interfaces.

The SPI protocol is used to communicate with the RF IC's ABACUS, ADDAG, JAVELIN, LVFRACN, ESCORT and PCIC. All these IC's are connected to the Patriot Bravo's QSPIA module. The interface comprises the lines SPIA_MOSI (TX), SPIA_MISO (RX), SPIA_CS's, and SPIA_CLK. The SPI bus is a synchronous bus, the timing clock signal CLK is sent while SPI data is transferred. Therefore, whenever there is activity on either MOSI or MISO, there should be a uniform signal on CLK.

The Patriot Bravo uses its module QSPIB to communicate with the real time clock (RTC) U0100, the external UART in the expansion head via the 40 pin connector J0500 and the GPS module via the 24 pin connector J0600.

RS232, USB, SB9600, SBEP Serial Interfaces

The Patriot Bravo uses four serial protocols to communicate with external devices: RS232, USB, SB9600 and SBEP. The interface lines are available on the rear or front connectors, dependent on the interface. Not all interfaces can be used at the same time.

SBEP Serial Interface

The Patriot Bravo communicates with the enhanced control head via the SBEP serial interface. This interface comprises line BUS+ and is available on the 12 pin front connector J0550. Op-amps U0102-1 and U0102-2 perform buffering and level shifting from 3 volts to 5 volts level. The Patriot Bravo uses its UARTB for the SBEP serial interface.

RS232 and SB9600 Serial Interfaces

The configuration of the RS232 and SB9600 serial interfaces depends on the terminal setup. If no expansion head is connected to the terminal, Patriot Bravo module UARTA provides either a 4-wire RS232 or an SB9600 interface on the 20 pin accessory connector J0400.

If at power up pin BUSY_OUT on the accessory connector J0400 is connected to pin BUSY_IN, the Patriot Bravo assumes that SB9600 equipment is connected and configures UARTA for the SB9600 interface. If both pins are not connected to each other at power up, the UARTA will be configured for RS232 interface. The interface comprises lines RS232_TX, RS232_RX, RS232_CTS, RS232_RTS. These lines are not buffered and at 0 or 3 volts level.

USB

The terminal is a 1.1 USB device with 12Mb/s. The interface comprises lines RS232_TX, RS232_RX and RS232_RTS. When a USB cable is connected to the terminal via JB the USB supply voltage is detected on line RS232_RTS and transferred to the controller via signal USB_INT.

The controller chooses between RS232 and USB interface via the signal USB_RS232 and switches the IC U0408. When the USB mode is used, the signal line RS232_TX is switched to USB D+ and the RX signal to D-. The USB signals are driven by the driver IC U0405. The RS232 lines to expansion head are then disconnected to eliminate the influence of stub lines.

Note

When an expansion head is connected to the terminal, the serial interfaces on the 20 pin accessory connector J0400 can not be used.

The UARTA is configured for an 8-wire RS232 interface, which is available on the 9 pin connector of the expansion head. This interface has standard RS232 levels and can be connected to an external data terminal.

In addition, the Patriot Bravo configures its QSPIB module to provide either a 4-wire RS232 or SB9600 interface with 5 volts level on the 25 pin expansion head connector. If line MUX_CTRL_1 is at 0 volt, the interface is switched to RS232 mode.

When the MUX_CTRL_1 line is at 3 volts, the interface is switched to SB9600 mode. The interface comprises lines BUSY_IN, BUSY_OUT, RESET_OUT, and the QSPIB lines SPIB_MOSI, SPIB_MISO, SPIB_CLK, SPIB_CS1_UART and is available on the 40 pin front connector J0500 with signals at 3 volts high level.

The Patriot Bravo uses the SB9600 interface to communicate with the motorcycle control head. If no motorcycle control head is connected, the interface can be used to control the terminal via the SB9600 protocol with an external control terminal.

Terminal Audio System

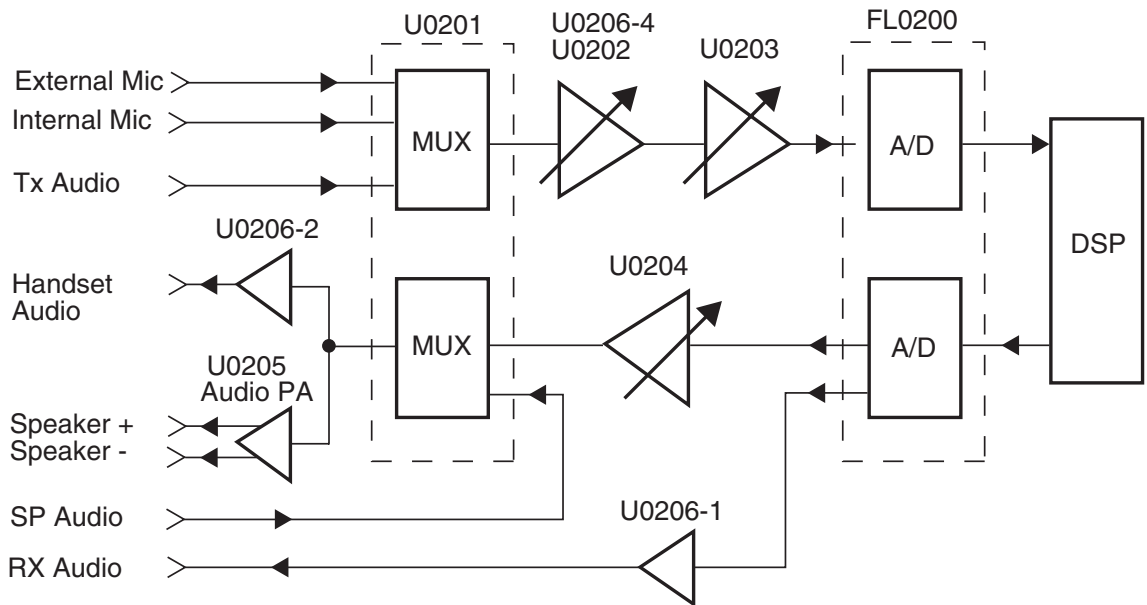

Figure 7 Audio Block Diagram

The Audio system consists of the following components:

- RX and TX path multiplexer
- RX and TX programmable potentiometer
- CODEC
- DSP
- Audio PA

TX Path

The speech audio is fed to the internal microphone input (INT_MIC), the external microphone input (EXT_MIC) or the TX audio input (TX_AUDIO). The internal and external microphone inputs have a DC bias prepared for connecting a microphone.

The TX audio input has a DC blocking capacitor. Multiplexer U0201 selects one of the possible inputs and feeds the signal to amplifier U206-4. The gain of this amplifier is switchable via gate U0202.

The programmable potentiometer U0203 attenuates the signal according to the terminal mode of operation. Finally, the CODEC FL0200 converts the analog signal into digital format and transfers it to the DSP via the serial audio port (SAP).

The DSP performs the functions of audio filtering, ACELP speech compression, digital modulation, and transfers the data to the RF section. When the terminal is operating in the telephone interconnect mode, the DSP performs the required tasks such as echo and noise reduction.

RX Path

The receiver feeds the digital output signal via the baseband port (BBP) to the DSP which performs the functions of digital demodulation, ACELP speech de-compression, and audio filtering. After processing, the DSP feeds the signal via the serial audio port (SAP) to the CODEC FL0200.

The CODEC converts the digital audio format to an analog signal. One of the CODEC's analog output signals is amplified by U0206-1 and then fed to the RX_AUDIO pin on the 20 pin accessory connector J0400.

The second output signal from the CODEC is fed to the programmable potentiometer U0204 which attenuates the analog signal according to the terminal mode of operation or the setting of the volume control.

The multiplexer U0201 selects between the signal from the potentiometer or the signal SP_AUDIO from the 40 pin expansion head connector J500 and routes the audio to the audio power amplifier (PA) U0205 and the amplifier U0206-2.

The amplified audio from U0206-2 is available on the HANDSET_AUDIO pins on the 20 pin accessory connector J0400 and the 40 pin expansion head connector J0500.

The audio PA has one inverted and one non-inverted output that produces the differential audio output signals SPEAKER+ and SPEAKER-.

Both signals are available on the 20 pin accessory connector J0400 and the 12 pin control head connector J0550.

RTC

The real time clock (RTC) IC U0100 supplies the controller with 32.768kHz clock. When the terminal is powered off, the RTC is supplied by a 5.1V supply URTC which derives from A+ via the zener diode VR0325.

After the terminal has been switched on, the IC is supplied from 3V_DIG and URTC is internally disconnected from the IC supply. When the terminal is disconnected from FLT_A+, the RTC continues to work for approx. 10 minutes.

TEMP_SENSE and BATTERY_VOLTAGE MUX

The controller alternately senses the battery voltage and the temperature on a dedicated input. The temperature information TEMP_SENSE is generated by the temperature sensor U5501 which is located close to the PA.

The battery voltage information derives from FLT_A+ via R0312 and R0313. These signals are input to the analog multiplexer U0104. With the PWM_ADC_SEL line, the controller selects which signal is routed to the comparator U0103-1.

The comparator compares the voltage from the multiplexer and the filtered (R0115 and C0113) pulse width modulated signal PWM_ADC_REF from the controller.

This PWM signal is adjusted by the controller until the comparator output changes its state. Thus the voltage either battery or temp sense can be determined.

GPS connector J0600

On this connector an optional GPS module electrically interfaces to the terminal. Two voltages, 3V_DIG and a protected SWB+, are available to supply the GPS circuitry. The GPS module communicates with the controller via the SPIB bus and the module is activated by SPIB_CS0_UART.

Furthermore a 32.768 kHz clock signal from the terminal is provided to the GPS module on J0600. The controller ports SIM UART0 and SIM UART1 are also routed to J0600 in order to provide the signals for a SIM card device.

SIM card connectivity

All SIM card signals are also available on the connectors, J0450, J0570 and J0600.

EMERGENCY

The signal EMERGENCY has an internal 4k7 pull up to FLT_A+. When the EMERGENCY signal pulls to ground during the "OFF" state of the terminal, the regulators U0300, U0301 and U0302 are powered on by means of Q0301 and Q0303. INT_SWB+ is supplied to the terminal through Q0301.

The controller reads the EMERGENCY information via Q0158 when it comes out of the POR and applies a high signal to SOFT_TURN_OFF and thus keeps the terminal powered on.

When EMERGENCY is applied during the "ON" state of the terminal, the controller also reads the EMERGENCY information via Q0158.

IGNITION

The IGNITION line is accessible on the 20pin accessory connector J0400 on pin 10 and the 40 pin expansion board connector J0400 on pin 27.

They are routed to a common 4k7 pull down resistor R0404. When the IGNITION signal exceeds approx. 4V, the regulators U0300, U0301 and U0302 are powered on by means of Q0302, Q0301 and Q0303. INT_SWB+ is supplied to the terminal through Q0301.

The controller reads the IGNITION information via Q0160 when it comes out of the POR.

General purpose inputs and outputs

HOOK

The HOOK GPIO is used as a digital input with a 2k2 pull up resistor R0154 to 5V. The HOOK function is detected if the signal is active low.

PA_ENABLE

The PA_ENABLE GPIO is used as a digital input with a 2k2 pull up resistor R0155 to 5V. The PA_ENABLE function is detected if the signal active low.

EXTERNAL_PTT

The EXTERNAL_PTT GPIO is accessible on the 20 pin accessory connector J0400 on pin 3 and the 12 pin control head connector J0550 pin 5. They are routed to a common 4k7 pull up resistor R0160 to 5V. EXTERNAL_PTT is detected if the signal active low.

EXT_ALARM

The EXT_ALARM GPIO is used as a digital output with a 4k7 pull up resistor to FLT_A+. When EXT_ALARM occurs, the transistor Q0159 switches to low.

GPS Sub Module

The MTM800 ENH GPS is based on the Phoenix GAM IC (PGAM), which comprises a custom mixed mode RF-DSP IC in a single chip FBGA package.

It is a self contained GPS receiver capable of producing a final position including full tracking and data decode capability.

The GPS signal that applies to the RF cable connector is filtered by two SAW filters FL1 and FL2. It is amplified by a low noise amplifier (LNA).

The input of the GPS receiver at the RF FME connector is DC coupled.

A voltage regulator on board provides about 20mA at 5V DC voltage to an external antenna low noise amplifier (LNA).

This phantom voltage is applied to the input by the RF coil L1.

The supply voltages GPS_2V and GPS_3V of the PGAM-IC are derived from two on board voltage regulators U2 and U3.

A 26MHz TCXO provides the reference clock to the PGAM IC.

Data communication takes place via the serial SPI bus.

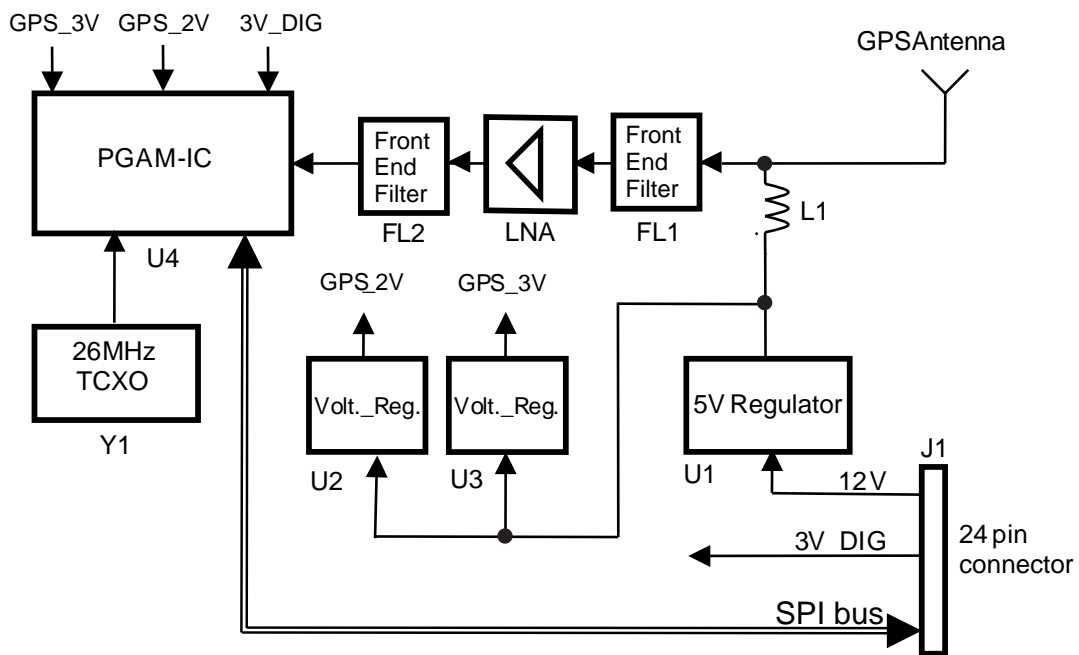

Figure 8 GPS Module Block Diagram

CHAPTER 4.2

THEORY OF OPERATION (CONTROL HEADS)

This chapter contains the descriptions of the different configurations of the control head:

- Control Head in Dash Mount configuration
- Control Head in Remote Mount configuration
 - Remote Back Head
 - Remote Mount Head
 - Expansion Head
- Control Head in Motorcycle configuration

Control Head in Dash Mount configuration

The control head in dash mount configuration consists of the main board, the liquid crystal display (LCD) module, the keypad board, the keypad, the rotary and push button, the EMERGENCY button, the GCAI accessory connector, the 3-colour status LED and the housing.

The display module contains a colour 2.8" VGA TFT display.

The 3 colour status LED informs the user about the radio status

The functions of the control head are driven by the OMAP330 microcontroller from Texas instruments.

Power Supplies

The power supply to the control head is taken from the host radio's FLT A+ voltage via connector J101 pin 3. It is used to power up the control head.

The regulator U513 provides an unswitched stabilized 5V to constantly power some circuits.

The switching regulator U501 produces 5V when the system is switched ON. The output voltage of U501 feeds the following regulators U503, U504 and U505. Furthermore the VCC_5 voltage is used to supply the keypad backlight.

The boost regulator U503 generates 23V for the display backlight.

The reset IC U502 enables the regulator U503 when the output voltage of U501 exceeds 2.8V. U503 produces the 1.5V core voltage for the OMAP microcontroller.

Only when the 1.5V is stable, the regulator U504 is enabled and generates 3.3V for USB and as input voltage for the two regulators U506 and U507. U507 provides 1.8V to the memory block of the OMAP and to the memories themselves.

U506 generates 2.8V for the I/O section of the OMAP.

The 2.8V also release the clear input of the D-Flip Flop U509. At the same time the crystal oscillator U515, Y501, R520 - R523 and C530 - C532 starts oscillating at 32.768 kHz and the binary counter in U515 starts counting. When the output Q12 of U515 goes to HIGH, the output of the D-Flip Flop U509 goes to HIGH and the OMAP is coming out of RESET.

In case the error output of U506 goes to LOW, the Flip Flop is cleared and thus the OMAP goes into RESET. U515 is also held in RESET and the oscillator stops working.

Power On / Off

The control head in dash mount configuration can be switched ON either by the ON rotary push button, the ON button in the keypad, the EMERGENCY button or by the radio via the accessory connector of the radio.

If one of the three buttons on the control head is pressed, the OR circuitry D510, D511 produces the signal ON_OFF_CONTROL, that switches the radio ON. When the radio powers ON it delivers a 5V level on the BUS+ and SCI_TX lines. The transistor couple Q508 then sets the signal BUS_ON to HIGH and the regulator U501 is enabled.

When all regulators are powered and the RESET signal has gone to HIGH, the OMAP controller starts operating.

The OMAP processor has to program the ON_HOLD line to HIGH in order to maintain the enable signal for U501, when the BUS+ line is used for communication later on.

Before the first message can be transferred, the interface has to be activated by setting the RADIO_COM_EN signal to LOW and the BUS_EN signal to HIGH.

RADIO_COM_EN enables the buffer U420-1 and supplies 5V to the operational amplifiers U421 and U422 via the transistors Q411 and Q412.

The BUS_EN signal connects the SCI_TX to the BUS+ line via Q410.

The other possibility to switch ON is when the radio is switched ON from its accessory connector either by IGNITION or by EMERGENCY. The regulator U501 is also enabled by the BUS+ signal in this case.

The system can be switched OFF by either the ON/OFF button in the keypad or by the radio via the IGNITION signal on the accessory connector.

If it is switched OFF by the ON / OFF button, the control head communicates this to the radio. After the radio has shut down the OMAP releases the ON_HOLD signal. If it is switched OFF by the radio it is told by a message from the radio to switch OFF. It has then also to release ON_HOLD.

Microprocessor Circuit

The control head uses the TI microcontroller (?C) OMAP330 (U201) to control the functions of the control head. The firmware is contained in a flash memory of 16Mbytes (U204). When the firmware is executed it runs in the SRAM U205. Flash and RAM have a separate data, address and control bus and operate at a 1.8V level.

The internal clock oscillator with the Xtal Y201 and the components R221 and C204/C205 generate the system clock of 12MHz.

The 32.768 kHz clock mentioned above is also fed into the OMAP controller.

The power supply design assures that the core is powered first and then the I/O and USB voltages are supplied to the controller. After this the system comes out of RESET.

The internal display controller in the OMAP loads the images into the display.

The display module is connected to the main board by the 40 pin connector J201

Keypad

The keypad interface of the OMAP can read the keypad matrix (COL5 - COL0 / ROW4 - ROW0) and discover which key has been pressed. The reading of the matrix is initiated by an interrupt.

The keypad PCB is connected to the main board by the 24 pin connector J401.

One Wire interface

The One Wire signal from the OMAP is connected via a level shifter Q305, D301 and R309/R310 to a switch U301. The switch routes the One Wire interface either to the front GCAI connector or to the rear of the remote back housing connector if present.

The direction of the switch is chosen by the OMAP GPO signal ONE_WIRE_SEL.

GCAI GPIOs and USB

The general purpose I/Os from the GCAI connector GPIO_0_PWR, GPIO_3_PTT and GPIO_4_HOOK are shifted from a 3.3V level to the OMAP I/O level of 2.8V by the bi-directional level shifters U302, U303 and U304. The direction of the signal is chosen by the OMAP GPOs GPIO_0_DIR, GPIO_3_DIR and GPIO_4_DIR.

The general purpose I/Os from the GCAI GPIO_1 and GPIO_2 are also level shifted by U323 and U325. As the USB signals D+ and D- share the same physical pin of the GCAI connector with the two GPIOs GPIO_1 and GPIO_2, the two switches U321 and U322 rout the respective signals from the OMAP to the GCAI connector.

With the switches U326 and U327 the signals can be switched between the front GCAI connector and the rear GCAI connector when a remote back head is present. The two switches are controlled by the logical signal USB1_GPIO and USB_FRONT_REAR.

The digital signal USB_MODE_SEL switches the resistors R327 and R328 to GROUND when the control head USB is required to be host. If the control head is an USB device USB1_PUEN activates the pull up resistor R326.

When the control head is USB host the signal USB_VBUS_ENA enables the power supply switch U324.

U324 provides 5V for USB to the FET switch and to the remote back head if present. The signal VBUS_FET_EN activates the FET Q326, which then switches the 5V to the GCAI connector. U324 has an internal over current detection, which will switch OFF the 5V if too much current is drawn. At the same time the signal VBUS_OC_DET goes to LOW and indicates the over current to the OMAP.

The comparator U328 compares the USB_VBUS signal with 3.3V and delivers a HIGH on USB1_DET when the VBUS voltage exceeds 3.3V. If the control head is USB master it will detect its own voltage. When the control head is USB device it will detect when a master is applied.

Backlights

The PWM output LCD_BL controls the current source Q201 and related circuitry. By this signal the current through the backlight diodes on the display module is determined. The supply voltage for the backlight diodes is the 23V source provided at J201 pin 32.

The PWM signal KPD_BL controls the brightness of the 3 colour LED. It is routed via Q324 to the emitters of the two red/green switches Q404 and Q405. The digital signals LED_GREEN and

LED_RED enable the colour by applying a HIGH to the basis of the respective transistor.Q504/Q505. When both switches are ON the light will be amber.

The digital signal KPD_BL_ON_OFF switches the keypad backlight ON or OFF by means of the FET Q401.

The PWM signal LED_EMERG is low pass filtered by R414/C410 and controls the brightness of the EMERGENCY key backlight.

Rotary and push button

The push button S401 connects the LOCK_ON signal to the FILT_A+. LOCK_ON is wired into the keypad matrix. The rotary S401 produces pulses on the two outputs PULSE_A and PULSE_B of a different phase when the knob is turned. These pulses are low passed R40 - R404 and C405/C406.

The B output is then applied to the D inputs of the two D-Flip Flops U401 and U402. The signal integrity of output A output is ensured by the two invert Schmitt triggers U403 and U404. The output pulse of U403 is the clock input for D-Flip Flop U401 and latches the status of the B signal with the rising edge. The second Schmitt trigger inverts the A signal another time and latches the B output into the D-Flip Flop U402 with its rising edge. Furthermore it serves as an interrupt RSW_1 for the OMAP, which is the required to read the outputs of the two D-Flip Flops RSW_2 and RSW_INT. From the polarity of these two signals the OMAP can determine whether the rotary was turned clockwise or counter clockwise. The Flip Flops get a reset from the general board-reset POR

Communication interface

In direct mount the radio and the control head communicate with each other via a two wire communication interface BUS+ and SCI_TX. This interface needs to be enabled by setting the RADIO_COM_EN signal to LOW and the BUS_EN signal to HIGH.

RADIO_COM_EN enables the buffer U420-1 and supplies 5V to the operational amplifiers U421 and U422 via the transistors Q411 and Q412.

The BUS_EN signal connects the SCI_TX to the BUS+ line via Q410.

The speed of this interface is 115kBaud/sec.

The physical interface to the radio is J102 with the following signals: GROUND, ON_OFF CONTROL, FILT_A+, BUS+, HANDSET_AUDIO, 5VD and SCI_TX.

Accessory Connector

The accessory connector J101 complies to the GCAI standard and provides the following signals: FRONT_ONE_WIRE, GPIO_3_PTT, HANDSET_AUDIO, USB_D-, GROUND, USB_VBUS, INT_MIC, USB_D+, GPIO_4_HOOK and GPIO_0_PWR. For further information please refer to the GCAI specification.

Control Head in Remote Mount configuration

In remote configuration a remote mount back housing is attached to the back of the control head.

It is connected to the control head main board through J603.

A 10 pin Remote Mount cable on P101 connects the Remote Mount Back Housing Board to the radio transceiver with either expansion head or remote head.

A 25 pin connector J105 gives access to the GCAI GPIOs, second USB, 4-wire RS232, Rear GCAI Pins and Audio.

The remote mount back head is detected by the OMAP by sending an I2C Bus request by means of the I2C clock and data lines I2C_SCL and I2C_SDA.

The routing of the GCAI GPIOs and the first USB is described already in the dash mount chapter. The 4-wire RS232 is connected to the UART 3 of the OMAP microcontroller. The signals for realizing the second USB port are directly provided by the OMAP and connected through the 40 pin connector J601 to the remote mount back housing board. The ON_OFF_CONTROL, BUS+, SCI_TX as well as the HANDSET_AUDIO and MIC lines are also routed via J602 to the rear of the remote mount back head.

The remote mount back head itself is controlled by I2C messages and the remote mount back head creates an interrupt to the OMAP when it has an I2C Bus message to deliver.

When the device was switched ON from the rear IGNITION line, the signal RM_ON turns to HIGH and switches the signal GCAI to HIGH by means of D350 and Q353. Then the same ON procedure starts as in dash mount configuration. After the device is in ON_HOLD and the OMAP has detected the ON source on the remote mount back housing it sent a LOW on RM_GCAI_PWR_ON_CLR to clear the RM_ON.

Remote Mount Back Head

Power supply

The remote mount back head is supplied from the control head main board with the FILT_A+ and unswitched 5 V when the device is switched OFF. When the device is switched ON by either the control head front panel or from the radio accessory connector, VCC_2.8V, VCC_3.3V and the switched 5V will be also provided by the control head main board.

When the device is switched ON from the rear IGNITION on the 25 pin rear connector by pulling J105 pin 25, to the battery voltage, the Transistor Q401 provides a rising edge to the D-Flip Flop U401 clock input. This latches the HIGH level on the D-input of U401 and creates an HIGH on RM_ON. This turns ON the control head main board as described above. At the same time a HIGH on IGN_SENSE is applied to the I2C port expander U501 and generates an interrupt to the OMAP. When the main board has powered ON as described above it clears the Flip Flop by pulling RM_GCAI_PWR_ON_CLR to LOW.

An optional 5V can be turned ON supplying the rear GCAI (U304) even when NGCH is turned OFF.

RS232

The MAX3232E U303 transceiver provides level translation to RS232 levels of the 4 wire RS232 interface connected to UART3 of the OMAP that is internally routed to the camera interface.

USB

There are 2 USB connections on the Remote Mount Back Housing Board. The first USB is shared with the front GCAI USB and the D- and D+ lines are switched ON the main board. The second USB is provided by the ISP1105 USB transceiver U302. It is interfaced to the OMAPs USB1 port. USB

power supply is separately switched for both USBs via Q306 and Q307. Detection and switching is controlled by the I2C port expanders U501 and U502.

Audio

Audio is on 2 wires for both directions and balanced and is routed from and to the Milan transceiver via the Gabel Hybrid U201. The Gabel Hybrid serves to transform the audio from unbalanced to balanced in order to reduce noise susceptibility on the remote cable. Receive or Handset Audio is routed to the main board and via 10uF to the 25 pin connector J105. Transmit or MIC audio is multiplexed by U203 and U204. Depending on PTT, these switches determine where the transmit audio is coming from. There are 3 sources: Front GCAI, Rear GCAI ON 25 pin connector and Rear MIC, also from the 25 pin connector J105.

1-Wire

The 1-Wire bus is routed from the 25 pin connector to the main board. It is shared between front and back GCAI and switched ON the main board.

Bus+/SCI_TX

Both BUS+ and SCI-TX serial communication lines have Pull-Ups to 5V. These 5 Volt needs to be turned ON/OFF by the OMAP in order to detect the ON/OFF status of the radio transceiver. This is done via the I2C port expander and Q503.

Analogue 4-level Input:

An analogue 4-level input pin is available on the 25 pin connector (U503). The 4 levels are preset by resistor dividers R540 - R551 and detected by comparators U503. The 4 states can be read by I2C expander 501.

I2C Port Expander settings and In/Output Matrix:

The heart of the Remote Mount Back Housing Board is the two PCA9535BS port expanders U501 and U502. The GPIOs and most detection and switching circuitry on the Back Housing Board are provided by these Port Expanders. The PCA9535BS provides 16 general purpose In/Output pins. It is interfaced to the OMAP's I2C bus via SDA (data) and SCL (clock) line. Both expanders are sharing the same interrupt, provided by an extra line GPIO_REQ.

Under normal operating condition, the second port expander U502 has only outputs and static inputs (HW ID) connected to it, so no interrupt is generated by U502. All Inputs that generate an interrupt are connected to U501.

Expansion Head

Overview

The Expansion Head GMCE4053A is a hardware interface to the MTM800 TETRA mobile radio. It gives access to the radio via three front side connectors. The following interfaces and protocols are provided:

- 8-wire RS232 Interface (9-pin D-type connector)
- 4-wire RS232 Interface (25-pin D-type connector)
- SB9600 Interface (25-pin D-type connector)
- SBEP Interface (10-pin Telco connector)

- 14 pin JTAG port

General

The 25-pin D-type, the 9-pin D-type connector and the 10-pin Telco connector are mounted on the Connector Board that is screwed into the Expansion Head housing. The Milan Expansion Board is installed at expansion board position. The interconnection between the Connector Board and the Milan Expansion Board is accomplished by a 40-pin flex connector.

A 12-pin flex and a 40-pin flex achieve the connection between the Expansion Board to the main radio chassis. A remote mount control head can be connected in a remote mount configuration via the 10-pin Telco connector. External DCE(s) can be connected via the 25 pin and /or 9 pin D type connectors.

Circuit Description

The Expansion Head Interface consists of several circuits to provide interfaces for the MTM800 TETRA mobile radio and the "outside world".

The Expansion board has an onboard 3-Volt Regulator U501 that is driven by 5-Volt supply from the main radio via the 12-pin flex on J1001. The supply voltage FLT_A+ is over current protected by the 2A fuse F101.

A second regulator U503 provides VAG_1 of 9.3V for the Gabel Hybrids U201. This regulator will be shut down through Q501 when the 5V are detached

The Gabel Hybrid U201 serves to transform the audio from unbalanced to balanced in order to reduce noise susceptibility on the remote cable.

There are several interfaces on the board but not all of them are available at the same time

The 8 wire RS232 interface consists of the MAX3238 true RS-232 transceiver (U101) that provides the EIA/TIA-232 and V.28/V.24 communications interface. This interface can be fully accessed through the 9-pin D-connector.

The circuit comprising ICs U401, U403 and U404 interfaces the MTM800 SPIB bus to an asynchronous serial-data communication port RS232 that is the 4-wire RS232 interface (pins 2, 3, 4, 5).

U401 is a MAX3100 universal asynchronous receiver transmitter (UART) with a baud rate generator driven by a 3.6864 MHz crystal U402.

U404 is a MAX3232 RS232 transceiver, translating the 3V logic levels to the RS232 levels.

The next interface is an SB9600 interface on the 25-pin connector (pins 8, 13, 15, 17) (SB9600_INTERFACE). The UART chip U401 also generates the transmit/receive signals of this interface.

The SBEP interface is provided on the 10-pin Telco remote connector. All signals necessary to connect a remote mount control head are routed through this connector. Those signals are fed from the radio via the 12-pin flex (J1001). The SBEP interface is always available on the Telco connector.

The Expansion PTT signal on the Telco connector is routed through the Expansion Board via Q102 and Q103. This line signals the radio that PTT is coming from the Expansion Head and the audio paths are routed through the Expansion Head.

The JTAG port is provided on the back of the Expansion board. The pin layout of the connector is setup in a way that the JTAG connector used for software debugging can be directly connected to this port. A 14-pin m/m 90° adapter is needed to connect to the test equipment.

To select a specific configuration, pin 23 (SB9600_SW) on the 25 pin D-type connector can be used.

Also the ACC3 pin on the 12-pin flex and pin 19 on the JTAG connector influence which interface is active in the Expansion Head at a specific time. Default if nothing is connected to the radio is that the 8-wire RS232 interface and 4-wire RS232 interface are active.

A high voltage (12V) on pin 23 enables the 8-wire RS232 interface on the 9-pin D-type connector. At the same time the SB9600 interface on the 25-pin connector is enabled. A low voltage (0V = default) on pin 23 enables the 8 wire RS232 interface on the 9-pin connector and the 4 wire RS232 interface on the 25-pin connector.

If a device is connected to the accessory connector of the radio, the 8-wire RS232 interface in the Expansion Head is disabled. Also, if the JTAG port is used, a 3-Volt level is applied to pin 19 of the JTAG, the 8-wire RS232 interface is disabled.

Remote Mount Head

General

The remote mount head and the radio are connected via 10-pin TELCO connectors. A 12-pin flex connects the radio to one remote mount PCB.

Description

The remote mount board basically routes the signals necessary to drive a control head from the radio to the remote mount cable and to the control head. The signals (ON_OFF_CONTROL, BUS+, SCI_TX and the supply voltage) are directly routed from the flex connector J301 to the TELCO connector J302. Microphone and speaker audio are transformed from unbalanced to balanced by the Gabel Hybrid U202 in order to reduce noise susceptibility on the remote cable.

The regulator U201 provides VAG_1 of 9.3V for the Gabel Hybrids U202. This regulator will be shut down through Q101 when the 5V are detached. The supply voltage FLT_A+ is over current protected by the 2A fuse F101.

VR301 - VR304 protects the board against electrostatic discharge

Control Head in Motorcycle configuration

When the control head is used on a motor cycle, it is electrically in remote configuration. The housing of the remote mount back head and the TELCO connector are mechanically modified to meet the IP67 requirement.

CHAPTER 5

PROGRAMMING THE TERMINAL

Note: For programming the terminal, refer to TETRA Customer Programming Software (CPS) Start-up User Guide, Publication No. 6802974C10_

THIS PAGE INTENTIONALLY LEFT BLANK

CHAPTER 6 TEST SETUP & TESTING

 WARNING	<p>Any level 3 repairs can deeply affect the performance of the MTM800 ENH terminal and may cause a new tuning procedure.</p> <p>This tuning procedure can only be applied by certain authorized Motorola depots where the appropriate TEST&TUNE EQUIPMENT is available.</p> <p>The appropriate TEST&TUNE EQUIPMENT is a special automated test equipment which is only available at some Motorola factories and Motorola repair centers.</p>
--	--

Typical Test Setup

Before Testing

Carry out the following instructions before testing:

- Connect the DC cable to the DC connector on the terminal.
- Connect the other side of the DC cable to the DC output connector on the power supply
- Connect an RF cable to the N-type RF Connector of the IFR.
- Connect the other side of the RF cable to the antenna connector on the terminal.
- Set the DC voltage on the power supply to 13.2 Volts.
- Switch on the terminal.

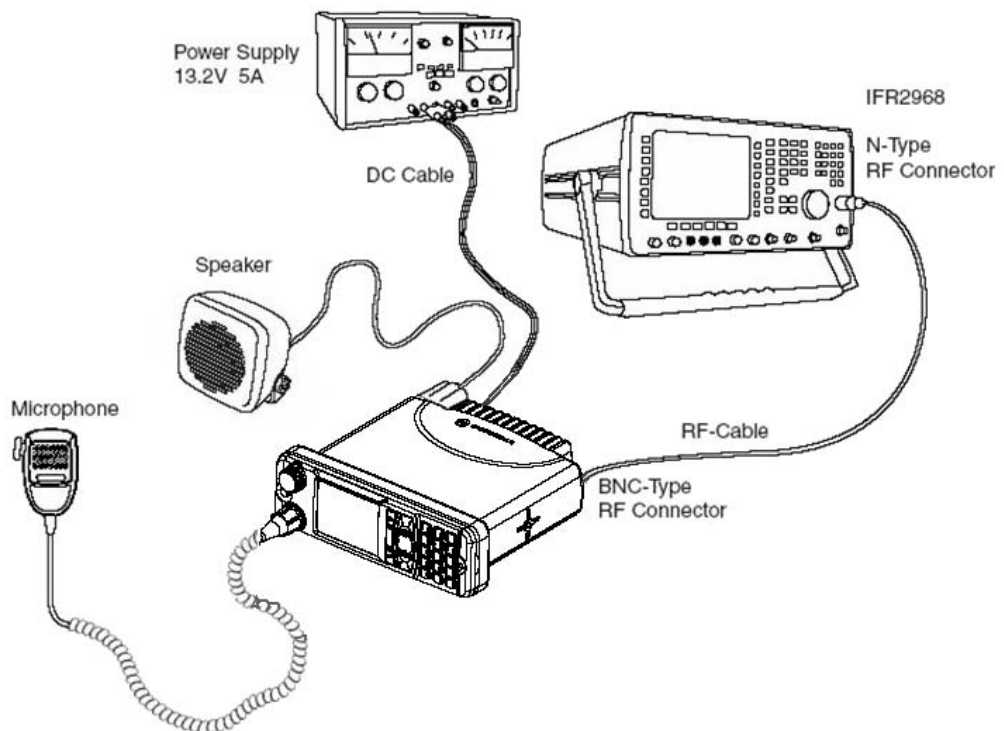

Figure 1 Typical Test Setup

Test Equipment

The table below lists the special test equipment required for servicing TETRA mobile terminals.

Table 1 Test Equipment

Name	Part Number
Digital Multimeter	R1072_
220V Power Supply	R1011_/220V
TETRA SVC MON. MOBILES ONLY	WADN4161A
TETRA SVC MON. MOB.+ DIR.MODE	WADN4163A
TETRA SVC MON. MOB.+ BASE ST.	WADN4164A
TETRA SVC MON. MOB.+ BASE ST. + DIRECT MODE	WADN4173A
TETRA SVC MON. MOB.+ DIR.MODE + MPT1327/1343	WADN4233A

Test Check List

The following table summarises the required test setups.
Receiver Tests

Table 2 Test setup

No.	Test Name	Test Setup	Terminal Setup	Test Conditions	Limits	
1.	IFR System Setup and Manual Test Screen	Control Channel		2040		
		Traffic Channel		2040		
		Time Slot		3		
		Country Code		262		
		Network Code		75		
		Base Color		1		
		Location Area		224		
		Min Rx Level				-110dBm
		Max Tx Level				35dBm (3.2W)
		Access Parameter			-33dBm	
		Mobile Power	35dBm (3.2W)			
Burst Type			Normal			
2.	Base Station Registration	RF Gen Level	851.0125MHz	-90dBm		
3.	Receiver RSSI	RF Gen Level	Cells Info RSSI TRACE	-90dBm		
4.	Transmitter Tests	RF Gen Level	Range 1 Test Group	-90dBm		
		Burst Power			33-37dBm	
		Timing Error			<=0.25 Symbols	
		Frequency Error			-/+ 100Hz	
		Vector Error			Max 10% RMS, Max 30% Peak, Max 5% Residual	
5.	Call Processing Talk Back	1KHz Test Signal Group Mode	Range 1 Test Group	-90dBm		
6.	Call Processing Call to Mobile	Private Mode Private Call	Private Mode			
		RF Gen Level Burst Power		-90dBm	33-37dBm	
		Timing Error			<=0.25 Symbols	
		Frequency Error			-/+ 100Hz	
		Vector Error			Max 10% RMS, Max 30% Peak, Max 5% Residual	

Table 2 Test setup

No.	Test Name	Test Setup	Terminal Setup	Test Conditions	Limits
7.	Digital Duplex Test (Tx)	RF Gen Level	Private Mode	-50dBm	
		Burst Power			10-22dBm
		Timing Error			<=0.25 Symbols
		Frequency Error			-/+ 100Hz
		Vector Error			Max 10% RMS, Max 30% Peak, Max 5% Residual

1. Simulate Base Station (registration)
2. RSSI Test

Transmitter Tests

1. Power Profile
2. Power Burst (Control Range)
3. Tx Burst Timing Error
4. Tx Frequency Error
5. Vector Error RMS, Peak and Residual

Call Processing Tests

1. Talk Back
2. Call to Mobile

Duplex Test

1. Digital Duplex Test (Tx)

Measurement Capabilities:

Bar chart display for Tx Power, Frequency Error, Vector Error RMS, Power Analyzer, Spectrum Analyzer, Vector Analyzer, Vector Diagrams.

Configuration of the IFR 2968 System Setup

The setup depends on the firmware version of the IFR 2968, the firmware version of the terminal and the customer programming of the terminal.

>>The following table should be taken only as an example of how to proceed for setup.<<
Perform following steps to configure the IFR2968 System Setup with the terminal settings:

1. Turn ON the IFR.
2. Press the "Systems" Mode Key (wait until the digital system is initialised).
3. Press the "Tetra Mobile" soft key.
4. Press the "Setup" soft key and enter the System Parameters Screen.
5. Press the "Channel Plan" or "System Type" soft key.
6. Press the "More" soft key if "User Defined" cannot be seen.
7. Press the "User Defined" soft key.

Note: Press the "More" soft key, if any of the following keys is not displayed.

8. Perform the following steps to setup the system parameters:
 - a. Press the "User Defined" soft key.
 - b. Press the "Frequency Band" soft key and press the "8 (800MHz)" soft key.
 - c. Press the "Offset" soft key and press the "3 (12.5kHz)" soft key.
 - d. Press the "Duplex Spacing" soft key and press the "1 (45MHz)" soft key.
 - e. Press the "Reverse Operation" soft key and press the "0 (Normal)" soft key.
 - f. Press the "Channel Block 1" soft key.
 - g. Press the "Channel Block" soft key and press the "Include" soft key.
 - h. Press the "Lowest Channel" soft key and enter "2040" using the data keys followed by the "Lowest Channel" soft key.
 - i. Press the "Highest Channel" soft key and enter "2800" using the data keys followed by the "Highest Channel" soft key.
 - j. Press the "Lowest Tx Freq" soft key and enter "806.0125" using the data keys followed by the "MHz" key
 - k. Press the "Duplex Offset" soft key and enter "45" using the data keys followed by the "MHz" key
 - l. Press the "Channel Spacing" soft key and enter "25" using the data keys followed by the "kHz" key
 - m. Press the "Return" soft key.
 - n. Verify that channel block 2 to 8 are excluded.
 - o. Press the "Return" soft key.
9. Press the "Control Channel" soft key and enter "2040" using the data keys followed by the "Control Channel" soft key.

10. Press the "Traffic Channel" soft key and enter "2040" using the data keys. Press the "Traffic Channel" soft key again and check that the marker goes to Timeslot. Press data key "3" followed by the "Traffic Channel" soft key, to change to Timeslot "3".
11. Press the "Country Code" soft key.
Enter "262" and press the "Country Code" soft key.
12. Press the "Network Code" soft key.
Thereafter, enter "75" and press the "Network Code" soft key.
13. Press the "Base Color" soft key.
Thereafter, enter "1" and press the "Base Color" soft key.
14. Press the "Location Area" soft key.
Thereafter, enter "224" and press the "Location Area" soft key.
15. Press the "Min Rx Level" soft key.
Thereafter, enter "-110dBm" and press the "Min Rx Level" soft key.
16. Press the "Max Tx Level" soft key.
Thereafter, enter "35dBm (3.2W)" and press the "Max Tx Level" soft key.
17. Press the "Access Parameter" soft key.
Thereafter, enter "-33dBm" and press the "Access Parameter" soft key.
18. Press the "Test Mode" soft key. Press the "Enable" soft key.
19. Press the "Base Service" soft key.
20. Press the "Suport" soft key if it is displayed
or verify that the following values are displayed:

POWER ON REGISTRATION:	REQUIRED
POWER OFF DE-REGISTRATION:	REQUIRED
PRIORITY CELL:	YES
MINIMUM MODE SERVICE:	NEVER USED
MIGRATION:	SUPPORTED
SYSTEM WIDE SERVICE:	NORMAL MODE
TETRA VOICE SERVICE:	SUPPORTED
CIRCUIT MODE DATA SERVICE:	SUPPORTED
(RESERVED):	NOT AVAILABLE
SNDCP SERVICE:	NOT AVAILABLE
AIR INTERFACE ENCRYPTION:	NOT AVAILABLE
ADVANCED LINK:	NOT SUPPORTED

Note: The displayed values are factory defaults and should not be changed.

21. Press the "Return" soft key.
22. Press the "Neighbor Cell" soft key.
23. Verify that the following values are displayed:

NEIGHBOUR CELL BROADCAST:	NOT REQUIRED
BROADCAST INTERVAL:	10s
NEIGHBOUR CELL CHANNEL:	0000

NEIGHBOUR CELL LOCATION AREA: 00001
NEIGHBOUR CELL IDENTIFIER: 01
SLOW RE-SELECT THRESHOLD: 10dB
SLOW RE-SELECT HYSTERESIS: 10dB
FAST RE-SELECT THRESHOLD: 10dB
FAST RE-SELECT HYSTERESIS: 10dB

Note: The displayed values are factory defaults and should not be changed.

24. Press the "Return" soft key.
25. Verify that "Trunking Type" is set to "Message".
26. Press the "Call Type" soft key to enter the "Call Type" screen.
27. Press the "Private Call" soft key.
28. Press the "Simplex Duplex" soft key and "Simplex Call" soft key.
29. Press the "Signal Type" soft key and "Direct set –up" soft key.
30. Press the "Priority" soft key. Thereafter, enter "00" and press the "Priority" soft key.
31. Leave "Calling Party SSI" setting to default value
32. Press the "Return" soft key.
33. This completes the System Setup configuration

Configuration of the IFR 2968 Manual Test Screen

The setup depends on the firmware version of the IFR 2968, the firmware version of the terminal and the customer programming of the terminal. The following procedure is only an example.

1. To enter "Manual test" screen, press the "Manual" soft key.
2. Press the "Control Channel" soft key. Thereafter, enter "2040" and press the "Control Channel" soft key (IFR "2040" = Rx 851.0125MHz).
3. Press the "Traffic Channel" soft key. Enter "2040" and press the "Traffic Channel" soft key. The marker goes to Timeslot. Enter "3" and press the "Traffic Channel" soft key. (**Note** that the Traffic Channel number changes automatically after entering the Control Channel number).
4. Press the "RF Gen Level" soft key. Thereafter, enter "-90" and press "dBm" data keys followed by "RF Gen Level" soft key.
5. Press the "Mobile Power" soft key, enter "35 dBm/3.2W", using soft key.
6. Press the "Burst Type" soft key and "Normal" soft key.
7. This completes the Manual test equipment configuration setup.

Note: The System Setup Configuration Data is saved even after the power is turned off. However, the Manual Test Setup is not saved.

RF Tests

Receiver Tests

Simulate Base Station (registration)

1. Turn the terminal ON
When the terminal is in Trunked Mode, continue with step 2. Otherwise perform steps a through c.
 - a. Press "Options" using the Lower (soft) key
 - b. Press the "Down" navigation key to scroll to "Trunked Mode".
 - c. Press "Select" using the Lower (soft) key
2. Check that registration and "ITSI: ---/---/01490199" (as example only) is displayed on the IFR "Manual Test" screen.

Note: The number "01490199" is the terminal ID (ISSI) which is displayed when the terminal is switched on.

RSSI Test

Note: To perform procedure below the Test Page field must be enabled using the CPS

Before carrying out the following steps, record the Insertion loss (dB) of the cable loss value - (X) dB.

1. In the IFR Manual Test Mode, press the "RF Gen Level" Soft Key and enter -90 dBm.
2. Before testing, the terminal should be configured to RSSI mode using the following sequence. When performing steps 3 through 6, make sure that you press the control head keys sequentially (less than a second between every consecutive press).
3. Press the "*" key.
4. Press the "#" key.
5. Press the "Menu" key.
6. Press the "Right Navigation" key.

Hereafter, there is no need for quick sequence of pressing the control head keys.

7. Press the "Down" navigation key to scroll to "Cells Info".
8. Press "Select" using the Lower (soft) key.
9. Press the "Right" navigation key to scroll to the RSSI monitoring screen.
10. Press "Trace" using the Lower (soft) key.

Note: RSSI results will flash on the screen every few seconds.
The display shows: **SERV: 0/34348**

RSSI: -90
CX: 20
CHQ: 99/E0

Disregard the "SERV", "CX" and "CHQ" results.

Actual RSSI measured
=IFR RF Gen Level - Cable insertion loss +/- other stray losses.

Range of Actual RSSI measured
= -90dBm - XdB (cable) +/- 1 dB.

Terminal RSSI result should be within the range of Actual RSSI.

To stop the "Trace" process, perform the following. When performing steps 11 through 14, make sure that you press the control head keys sequentially (less than a second between every consecutive press):

11. Press the "*" navigation key.
12. Press the "#" key.
13. Press the "Menu" key.
14. Press the "Right Navigation" key.

Hereafter, there is no need for quick sequence of pressing the control head keys.

15. Press "Select" using the Lower (soft) key.
16. Press "Stop" using the Lower (soft) key.
17. Press "Back" using the Upper (soft) key twice.

Transmitter Tests

Before you start these tests, make sure that the terminal is in Trunked Mode.

1. Press "Options" using the Lower (soft) key.
2. Press the "Down" navigation key to scroll to "TG by abc".
3. Press "Select" using the Lower (soft) key.
4. Scroll to one of the available groups and press select using the Lower (soft) key.
5. In the IFR Manual Test Mode press the "RF Gen Level" soft key. Enter "-90dBm" by pressing the data keys and "RF Gen Level" key.
6. Press the "PTT" of the terminal and monitor the IFR "Manual Test" screen which displays the Power Profile, Burst Power, Timing Error, Frequency Error and Vector Error.

Note: You have to hold the PTT in the pressed position long enough to enable you to read the results.

- Power Profile:	Passed.
- Burst Power Required Results:	33-37dBm.
- Timing Error:	≤ 0.25 symbols.

- **Vector Error:** **Max 10% RMS,
Max 30% Peak,
Max 5% Residual.**
- **Frequency Error:** **+/- 100Hz.**

7. Press the "Clear Down" soft key, to proceed with other tests.

Call Processing Test

Before you start these tests, make sure that terminal and test equipment are configured the same as given in the Transmitter Test.

Talk Back

1. Press "Options" using the Lower (soft) key on the terminal and change to one of the available groups.
2. In the IFR Manual Test Mode press the "RF Gen Level" soft key. Enter "-90dBm" by pressing the data keys and "RF Gen Level" key.
3. Press the "PTT", press the "Talk Back" soft key on the IFR and speak into the mic of the terminal for at least 3sec, then release "PTT". You will hear from the terminal speaker the last three seconds of the speech frames before the "PTT" has been released.
4. Press the "Test Sound" soft key to provide the 1kHz signal to the terminal speaker.
5. Press the "Silence" soft key to mute the 1KHz audio signal of the speaker.
6. Press the "Clear Down" soft key and check that the "Cleardown Complete" status appears on the IFR "Manual Test" screen.

Call to Mobile

1. In the IFR Manual Test Mode press the "RF Gen Level" soft key. Enter "-90dBm" by pressing the data keys and "RF Gen Level" key.
2. Press the "Call Mobile" soft key and select "Private Call" on the IFR. Verify that two beeps are heard from the terminal speaker.
3. Press the "Abort Call" soft key.

Duplex Test (Phone/Private Mode)

Digital Duplex Test (Tx)

1. In the IFR Manual Test Mode press the "RF Gen Level" soft key. Enter "-50dBm" by pressing the data keys and "RF Gen Level" key.
2. Dial a random 4 digit number (eg "9359") using the alphanumeric keys of the terminal, press "Calltype" using the Lower (soft) key until "Phone #" is displayed and press

the "Send" Key  .

The following results are displayed on the IFR “Manual Test” Screen

- **Power Profile:** **Passed**
- **Burst Power Required Results:** **10-22dBm**
- **Timing Error:** **≤ 0.25 Symbols.**
- **Frequency Error:** **-/+ 100Hz**
- **Vector Error:** **Max 10% RMS,
Max 30% Peak.
Max 5% Residual.**

3. Press the “Talk Back” soft key.
4. Speak into the terminal microphone and hear your speech (after a short delay) from the terminal loudspeaker.
Note: If you need more details, press the “Duplex Test” mode key.
5. Press the “duplex test (Tx)” soft key. The “Digital Duplex test” results will be displayed on the IFR screen providing you with either one of the following:
 - **bar charts measurement capabilities showing Tx Power, Frequency Error and Vector RMS in one screen**
 - **Tx Power (more details in Power Analyser)**
 - **Frequency Error (more details in Spectrum Analyser)**
 - **Vector RMS (more details in Vector Analyser)**

For Power Analyser Graph:

6. Press “power ana” soft key.
7. Check that the power frame falls within the limits.

For Spectrum Analyser Graph:

8. Press “spec ana” soft key.
9. Monitor the Tx frequency.

For Vector Analyser Diagram:

10. Press the “vector ana” soft key.
11. Monitor the diagram for the following:
 - **press “vector error” soft key for vector error.**
 - **press “mag error” soft key for magnitude error.**
 - **press “phase error” soft key for phase error.**
 - **Vector Error**
 - **Magnitude Error**
 - **Phase Error**

For Vector Diagram:

12. Press the “vector diagram” soft key.
13. View the following:
 - **press “symbol constel” soft key for graphical symbol constellation.**

- press “rotated vector” soft key to zoom in on the constellation.
- press “phase traject” soft key to view trajectory of the constellation.

14. Press the terminal "End" key. 

Manual Mode Testing

Preparation for Testing

Verify that the radio is turned off.

Press the "1", "2" and "3" keys together and then, press the On/Off key or the Rotary Push Button to turn the radio on. Keep the "1", "2" and "3" keys pressed until the display turns on.

The display shows "User test mode, Press any key to start, Press SoftKeys to scroll".

Tests

Note: Any key that will be pressed will cause the test to advance from one step to the next. You can use the soft keys to go to the next or back to the previous test. After a test has started you can press the upper soft key to go back to the start of the current test. At any time you can switch off the radio by pressing the On/Off key for 2 seconds.

1. Press any key to start the first test. The display shows "LCD Red-Green-Blue test".
2. Press any key consecutively. First the display shows horizontal red lines that become thicker with every key press, until it becomes fully red. Then the display shows vertical green lines that become thicker with every key press, until it becomes fully green. After that the display shows horizontal blue lines that become thicker with every key press, until it becomes fully blue.
3. Press any key to start the next test. The display shows "LCD Color brightness test"
4. Press any key consecutively. The display shows the color brightness levels "min", "low", "med" and "max". Verify the color brightness of the display.
5. Press any key to start the next test. The display shows "Display backlight test"
6. Press any key consecutively. The display shows the backlight brightness levels "min", "low", "med" and "max". Verify the brightness of the display.
Note: At level "min" the display contents is not visible.
7. Press any key to start the next test. The display shows "Keypad backlight test"
8. Press any key again. The display shows "Keypad backlight is off". Verify that the keypad backlight is off.
9. Press any key again. The display shows "Keypad backlight is on". Verify that the keypad backlight is on.
10. Press any key to start the next test. The display shows "Emergency backlight test"

11. Press any key consecutively. The display shows the emergency button brightness levels "min", "low", "med" and "max". Verify the brightness of the emergency button.
12. Press any key to start the next test. The display shows "Status LED test"
13. Press any key again. The display shows "Red LED is on" and the Red LED at the right side of the radio is lit.
14. Press any key again. The display shows "Green LED is on" and the Green LED at the right side of the radio is lit.
15. Press any key. The display shows "Orange LED is on" and the orange LED at the right side of the radio lit.
16. Press any key consecutively. The display shows the LED brightness levels "min", "low", "med" and "max". Verify the brightness of the orange LED at the right side of the radio.
17. Press any key to start the next test. The display shows "Keypad test"
18. Press any key again. The display shows all the radio keys.
19. Press every key, one by one. Each key you press causes its respective display to be highlighted. If you press a highlighted key again, the highlighting is removed. To exit this test before all keys are highlighted press the rotary push button.
20. Press any key to start the next test. The display shows "Rotary test"
21. Turn the rotary switch clockwise and counter clockwise. Each step causes the respective displayed arrow sign to be highlighted. Turn the rotary switch until the two respective "OK" labels are highlighted.
22. Press the rotary push button consecutively until "OK" is highlighted.
23. Press any key to start the next test. The display shows "Fist MIC test"
24. Press any key to continue. Connect a fist microphone. The display shows "Accessory connected"
25. Press PTT to highlight all "0".
26. Place the microphone on / off hook to highlight all "0".
27. Press any key again. The display shows "End of user tests", "Press any key to power off or use softkeys to scoll to any previous test".
28. This completes the test. Press any key to turn the radio OFF.

Service Flow Chart (Board Level)

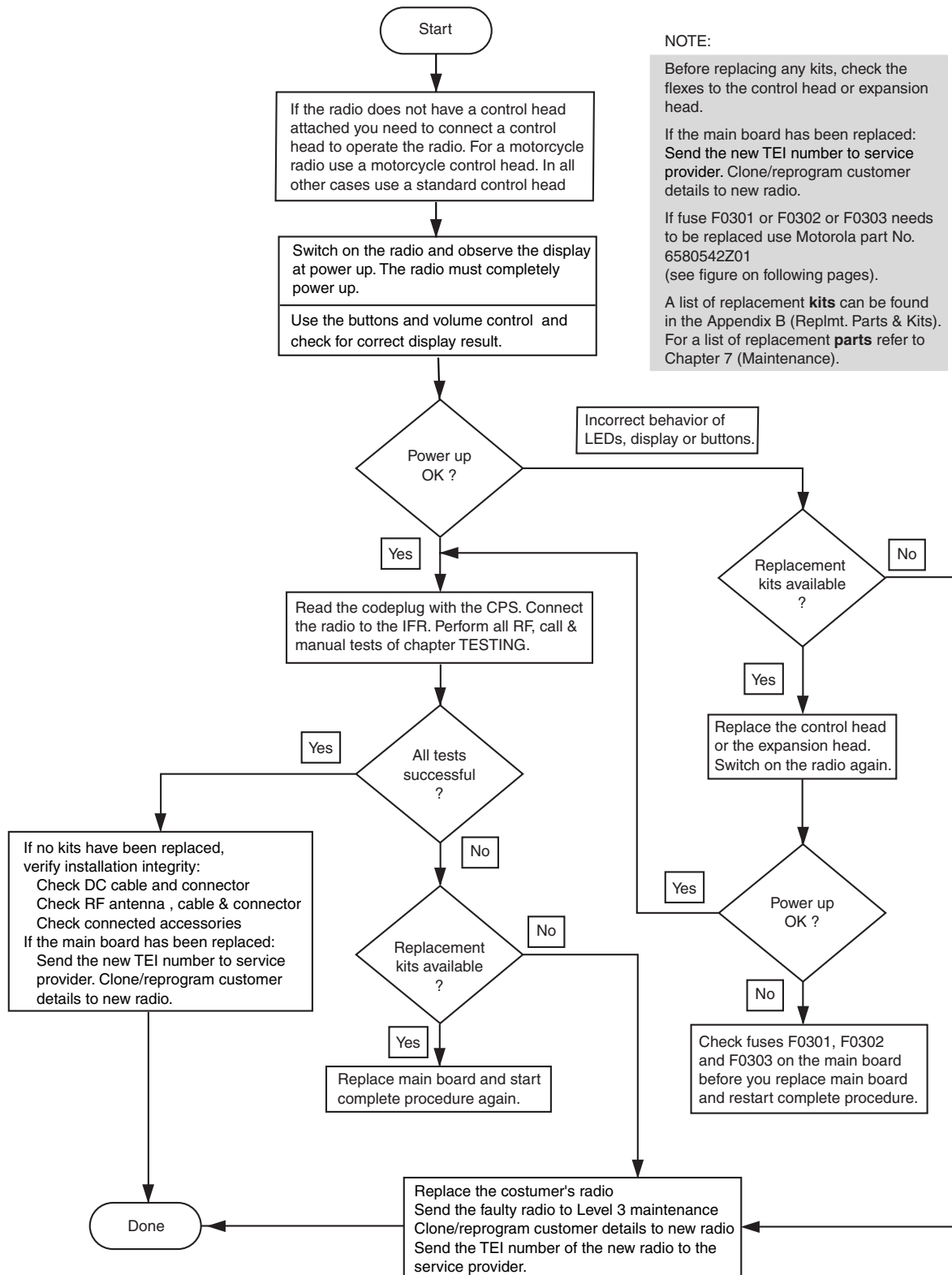

Figure 2 Servicing the MTM800 ENH

Fuses on the Mainboard

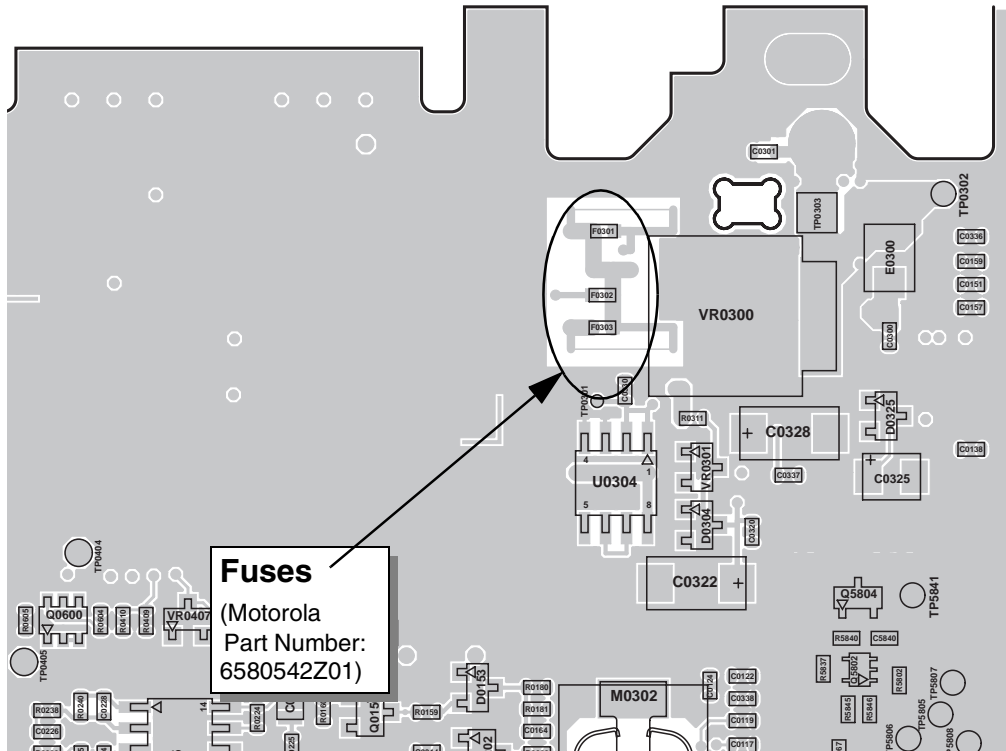

Figure 3 Position of Fuse F0301/2/3 (PCB Mainboard - TOP View)

CHAPTER 7

MAINTENANCE

Introduction

This chapter provides details about the following:

- Preventive maintenance (inspection and cleaning)
- Safe handling of CMOS and LDMOS devices
- Pre-baking of Integrated Circuits
- Repair procedures and techniques
- Disassembly and reassembly of the terminal
- Exploded views and parts lists

Preventive Maintenance

The terminals do not require a scheduled preventive maintenance program; however, periodic visual inspection and cleaning is recommended.

Inspection

Check that the external surfaces of the terminal are clean, and that all external controls and switches are functional. It is not recommended to inspect the interior electronic circuitry.

Cleaning

The following procedures describe the recommended cleaning agents and methods to be used when cleaning the external and internal surfaces of the terminal. External surfaces should be cleaned whenever a periodic visual inspection reveals the presence of smudges, compound, or grime. Internal surfaces (circuit boards and components) should be cleaned only when the terminal is disassembled for servicing or repair.

The only recommended agent for cleaning external terminal surfaces is a 0.5% solution (one teaspoon of detergent per gallon of water) of mild dishwashing detergent in water. The internal surfaces should be cleaned only with isopropyl alcohol (70% by volume).

NOTE: Internal surfaces should be cleaned only when the terminal is disassembled for service or repair.



CAUTION: The effects of certain chemicals and their vapors can have harmful results on certain plastics. Avoid using aerosol sprays, tuner cleaners, and other chemicals.

Cleaning External Plastic Surfaces

Apply the 0.5% detergent-water solution sparingly with a stiff, non-metallic, short-bristled brush to work all loose dirt away from the terminal. Use a soft, absorbent, lintless cloth or tissue to remove the solution and dry the terminal. Make sure that no water remains entrapped near the connectors, cracks, or crevices.

Cleaning Internal Circuit Boards and Components

Isopropyl alcohol (70%) may be applied with a stiff, non-metallic, short-bristled brush to dislodge embedded or caked materials located in hard-to-reach areas. The brush stroke should direct the dislodged material out and away from the inside of the terminal. Make sure that controls or tunable components are not soaked with alcohol. Do not use high-pressure air to hasten the drying process since this could cause the liquid to collect in unwanted places. After completing of the cleaning process, use a soft, absorbent, lintless cloth to dry the area. Do not brush or apply any isopropyl alcohol to the frame, front cover, or back cover.

NOTE: Always use a fresh supply of alcohol and a clean container to prevent contamination by dissolved material (from previous usage).

Safe Handling of CMOS and LDMOS Devices

Complementary metal-oxide semiconductor (CMOS) devices are used in this family of terminals, and are susceptible to damage by electrostatic or high voltage charges. Damage can be latent, resulting in failures occurring weeks or months later. Therefore, special precautions must be taken to prevent device damage during disassembly, troubleshooting, and repair. Handling precautions are mandatory for CMOS circuits and are especially important in low humidity conditions. **DO NOT** attempt to disassemble the terminal without first referring to the following CAUTION statement.



CAUTION: This terminal contains static-sensitive devices. Do not open the terminal unless you are properly grounded. Take the following precautions when working on this unit:

- **Store and transport all CMOS devices in conductive material so that all exposed leads are shorted together. Do not insert CMOS devices into conventional plastic “snow” trays used for storage and transportation of other semiconductor devices.**
- **Ground the working surface of the service bench to protect the CMOS device. We recommend using the Motorola Static Protection Assembly (part number 0180386A82), which includes a wrist strap, two ground cords, a table mat, and a floor mat.**
- **Wear a conductive wrist strap in series with a 100k resistor to ground. (Replacement wrist straps that connect to the bench top covering are Motorola part number RSX4015_).**
- **Do not wear nylon clothing while handling CMOS devices.**
- **Do not insert or remove CMOS devices with power applied. Check all power supplies used for testing CMOS devices to be certain that there are no voltage transients present.**
- **When straightening CMOS pins, provide ground straps for the apparatus used.**
- **When soldering, use a grounded soldering iron.**
- **If at all possible, handle CMOS devices by the package and not by the leads. Prior to touching the unit, touch an electrical ground to remove any static charge that you may have accumulated. The package and substrate may be electrically common. If so, the reaction of a discharge to the case would cause the same damage as touching the leads.**

Pre-baking of Integrated Circuits

Electronic components are generally coated with plastic material which has the nature of not being waterproof. If kept unsealed the components can absorb humidity. When soldered to the board (especially with reflow techniques) the sudden change in temperature can cause fissure or crack which can result in malfunction or damage.

To avoid this problem these moisture sensitive components (MS) should be stored and shipped in a sealed wrapping (dry pack). Processing must take place only with „dry components“ when an uninterrupted dry storage can be guaranteed, otherwise the components have to be pre-baked.

If a reflow procedure takes place close to MS components the whole board must be pre-baked.

Table 18 List of MTM800 ENH moisture sensitive components

Part. No.	MSL*	Description
5166554A01	3	ADDAG
5109841C71	3	GAM IC (on GPS option board)
5186988J77	3	JAVELIN
5185956E43	2A	FLASH 16MB
5185963A85	3	ABACUS AD9874
5166541A01	3	Patriot ROM3
5189233U61	3	PSRAM 4MB
5199434A01	2	Serial SPI EEPROM

*) Out of dry package Moisture Sensitivity Level (MSL) 2 : 1 year
 2A : 1 month
 3 : 168 hrs

Repair Procedures and Techniques - General

Parts Replacement and Substitution

When damaged parts are replaced, identical parts should be used. If the identical replacement part is not locally available, check the parts list for the proper Motorola part number and order the part from the nearest Motorola Communications parts center listed in the "SUPPORT CENTRES" section of this manual.

Disassembling and Reassembling the Terminal - General

Since these terminals may be disassembled and reassembled with the use of only six (board to casting) screws, it is important to pay particular attention to the snaps and tabs, and how parts align with each other.

The following tools are required for disassembling the terminal:

- Small flat blade screwdriver
- Dismantling Tool (Motorola Part No.: 6686119B01)
- TORX™ T screwdriver
- **TORQUES:** Diecast Top Cover (6x): 1.92 Nm ... 2.03Nm (17-18 lbin)
GPS Cover (5x), GPS Board (1x): 1.13 Nm +/- 10% (10 lbin +/- 10%)
UCM Board Cover (3x): 1.13 Nm +/- 10% (10 lbin +/- 10%)

NOTE: If a unit requires more complete testing or service than is customarily performed at the basic level, send this unit to a Motorola Authorized Service Center (refer to Appendix A: Support Centers). The following described disassembly procedures should be performed only if necessary.

Terminal Disassembly and Reassembly - Detailed

The procedure to remove and replace a Control Head, Top Cover or Transceiver Board is similar for all models of terminal. A typical procedure is therefore shown followed by specific disassembly procedures for Control Heads or Expansion Heads on terminal models

Control Head Removal

1. Insert the dismantling tool in the groove between the control head and the terminal assembly as shown in the Figure.
2. Press on the dismantling tool until the snap connectors on the side of the control head release from the terminal assembly.
3. Pull the control head away from the terminal assembly as shown below.

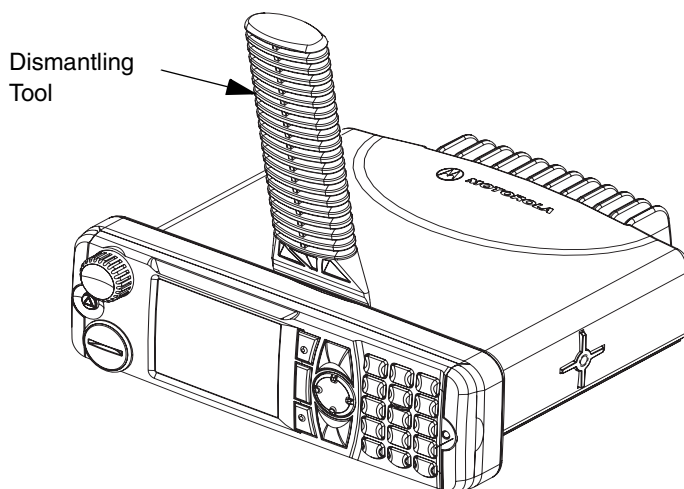

Figure 1 Typical Control Head Removal

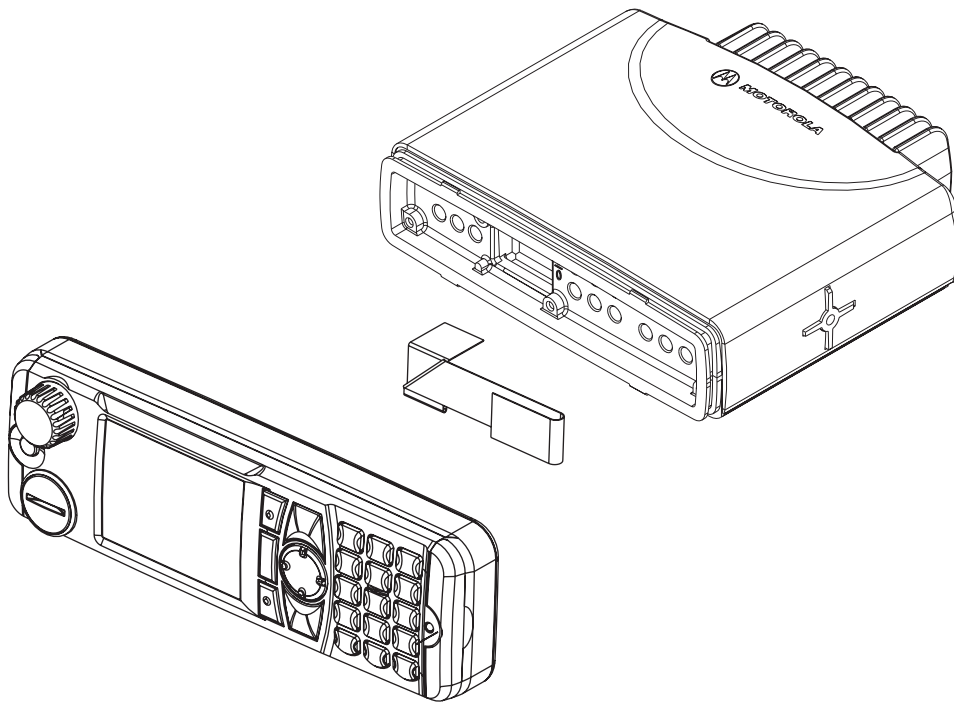

Figure 2 Flexible Connection Removal

4. Remove the flexible connection from the socket on the control head board.

Top Plastic Cover Removal

1. Insert the dismantling tool in the middle of the terminal assembly side groove as shown in Figure 3.
2. Press on the dismantling tool until the snap connectors on the side of the plastic cover release from the terminal chassis.
3. Lift the plastic cover from the chassis.

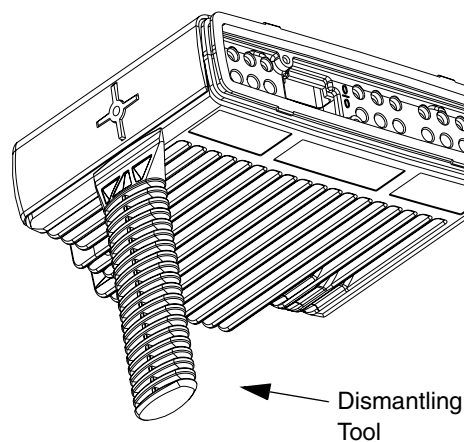

Figure 3 Top Cover Removal.

Transceiver Board Removal



CAUTION: Some terminals are equipped with a GPS module at the left side bottom of the transceiver and/or an additional UCM Board inside the transceiver cover plate, refer to special label at the cover plate (dotted line at the figure below).

There are flex cables installed connecting these boards to the main board. Take extra care not to tear off the flex when dis-assembling or re-assembling the board from/to the transceiver or this could damage the GPS/UCM Board and the main board (refer to chapter explosion views figure 11, 12 for a detailed view).

1. Remove six screws from the diecast cover using the T20 TORX™ driver as shown in Figure 4.
2. If existing remove the metal GPS cover from the bottom (5 screws, T10 TORX™). Remove the internal GPS board (one screw) from the transceiver and disconnect the flex cable from the main board.
3. Lift the cover from the chassis.

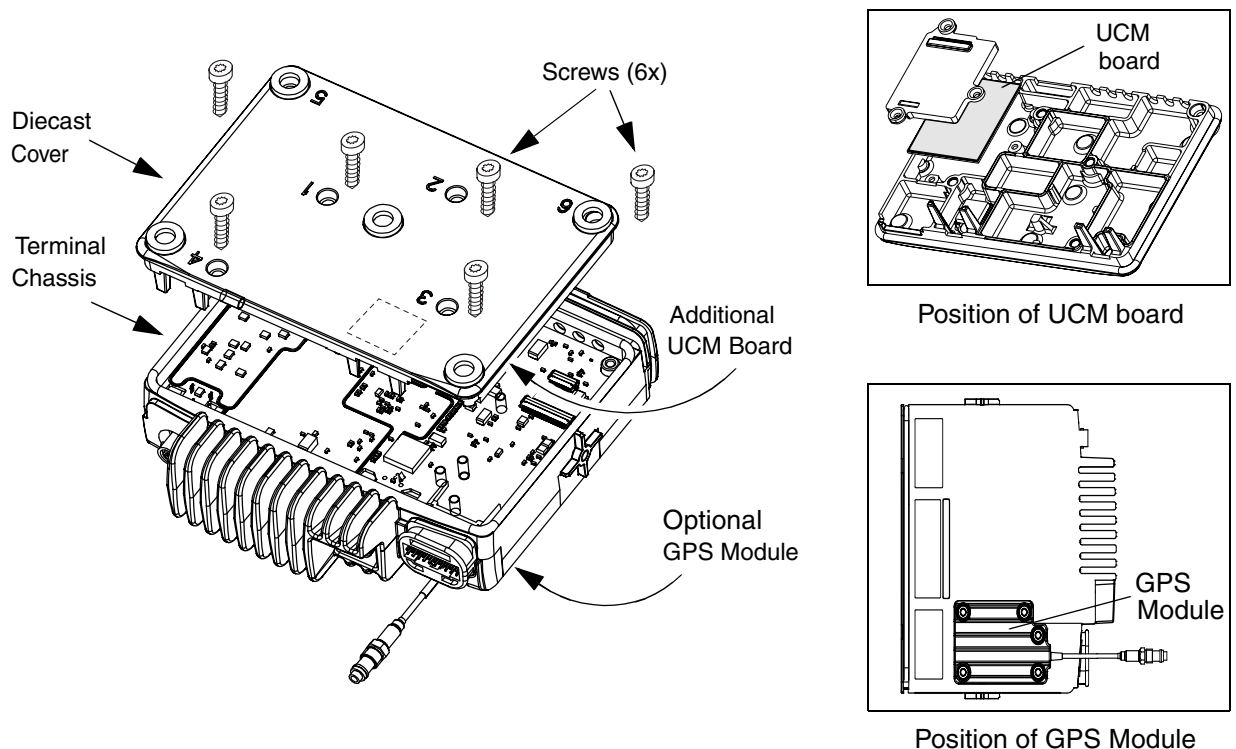

Figure 4 Diecast Cover Removal

4. Pull out the plastic accessory connector housing to the back.
5. Slowly lift the transceiver board on the edge at the front of the terminal (the edge that mates with the control head) and pull gently toward the front of the terminal as shown in Figure 5. Take care to slide the antenna connector and power connector out of the chassis towards the front.
6. If existing, take extra care of the UCM Board inside the cover plate and disconnect the flex cable from the mainboard.



CAUTION: The thermal pad can act as an adhesive and cause the leads of the heat dissipating devices to be over stressed if the board is lifted too quickly. If the board can't be easily lifted, the chassis must be heated up to 55 degree Celsius.

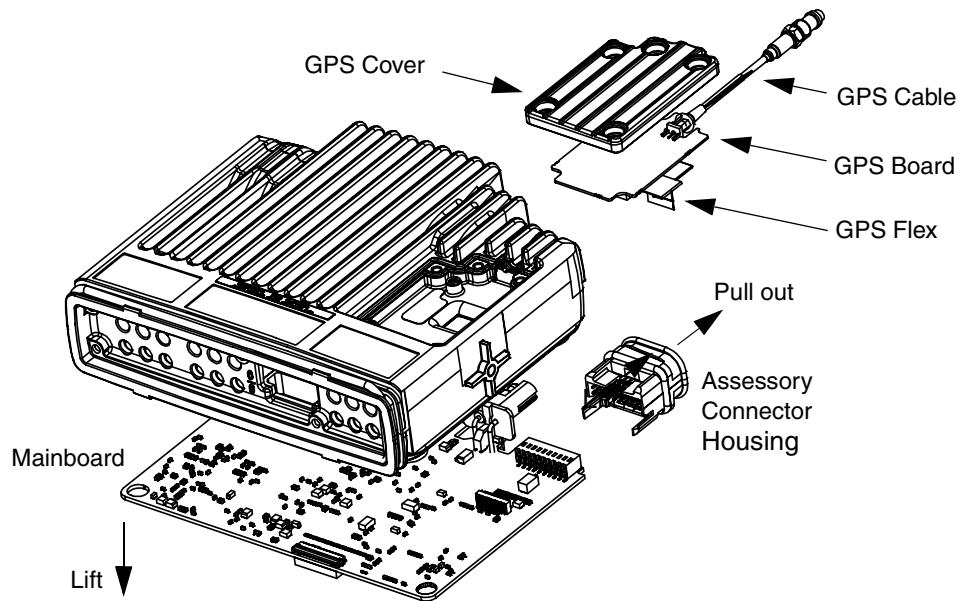

Figure 5 GPS and Mainboard Removal (view from bottom side)

Reassembly the Terminal Chassis And Transceiver Board (torques, see page 6-5)

1. Inspect the transceiver board and ONLY if the surface of the thermal pads show signs of damage, remove the thermal pads and apply thermal grease to the heatsink area on the chassis and heat dissipating devices.
2. Insert the transceiver board at an angle (approximately 30°) into the chassis taking care to slide the antenna connector and accessory connector into their cut-outs in the chassis.
1. Lower the transceiver board onto the chassis and align the two locating holes in the board with the locating pins in the chassis.
2. If a UCM board was mounted, reconnect the flex cable to the mainboard. Take care of the specific flex bending. Note: After removal the UCM board has to be reprogrammed (App. C).
3. Secure the cover to the chassis with the six screws previously removed.
4. Torque the six screws to 1.9 NM (17 in lbs) using the T20 TORX™ driver. Begin with screw 6 followed by 5 to 1. Since the screws usually take a set, torque the screws a second time (1.9 NM) in the same order.
5. If existing, reconnect the GPS flex cable and reassemble the GPS module and cover plate.
6. Refit top cover over the assembled terminal chassis. Press cover down until it snaps into place.

Control Head Fitting

1. Align the 'dot' or 'O' marking on the flex with the 'O' mark on the chassis to the socket on the terminal assembly as shown in Figure 2.
2. Check that the back housing o-ring seal is undamaged and fitted in the groove. Replace the seal if it is damaged (refer to the exploded view diagrams and parts list).
3. Fit the back housing to the control head. Ensure that the tags on the back housing align with the snap catch grooves on the control head. Press the back housing into place until it snaps into place.
4. Check that the terminal chassis o-ring seal is undamaged and fitted in the groove on the chassis assembly. Replace the seal if it is damaged.

Enhanced Control Head - Disassembly

1. To dismantle the control head housing from the back housing, insert the dismantling tool in the groove between the two housings as shown in the following figure.

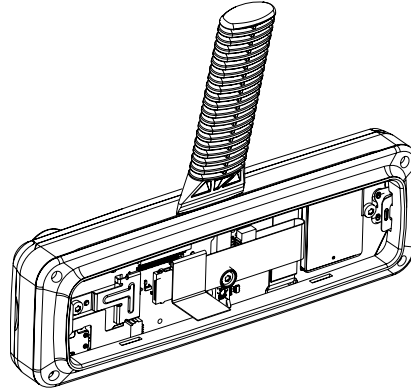

Figure 6 Control Head Back Housing Removal

2. Press the dismantling tool until the snap connectors on the side of the back housing release from the control head.

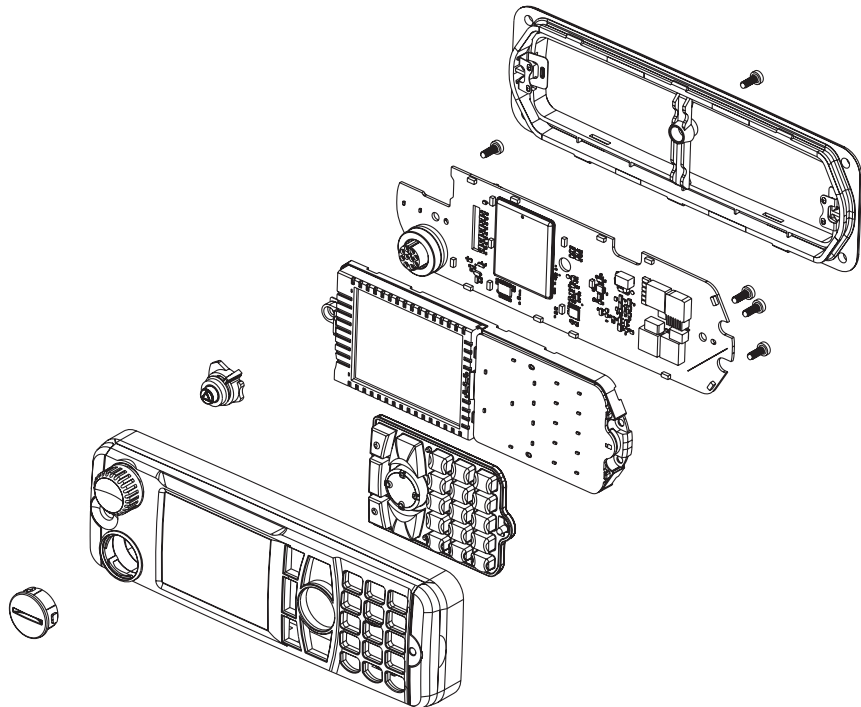

Figure 7 Control Head Board Removal

3. Remove the board from the control head housing by stretching the control head housing and pulling up on the board as shown in the Figures.
4. Remove the keypad from the control head housing by lifting up the rubber keypad.

NOTE Care should be taken not to touch or contaminate the conductive pads on the under side of the keypad or the conductive contacts on the printed circuit board.

Enhanced Control Head - Reassembly

1. Fit the rubber keypad onto the board ensuring that the on/off control and the board is located correctly with the cut-outs in the keypad.
2. On the board, rotate the on/off control spindle fully counter-clockwise.
3. Also, rotate the volume knob on the front housing fully counter-clockwise.
4. Align the board with the control head, inserting the on/off control spindle and connector through the holes in the control head.

Ensure that the keypad, on/off control spindle and microphone connector are aligned with the control head then press the board into place until it clicks.

Remote Mount Head - Disassembly



CAUTION: The terminal must be disconnected from the power supply before commencing any disassembly. The Installation Manual should be referred to for more detailed information on warnings and safety.

To Disassemble the Terminal from the Control Head

1. Remove the Control Head from the Transceiver by inserting the dismantling tool (Motorola part number 6686119B01) in the recess between the Control Head and the Transceiver.
2. Split the Control Head into Front and Back housings by inserting the dismantling tool in the recess between them.

NOTE: To minimize cosmetic damage disassemble from the bottom side (label side).

3. Remove the flex.

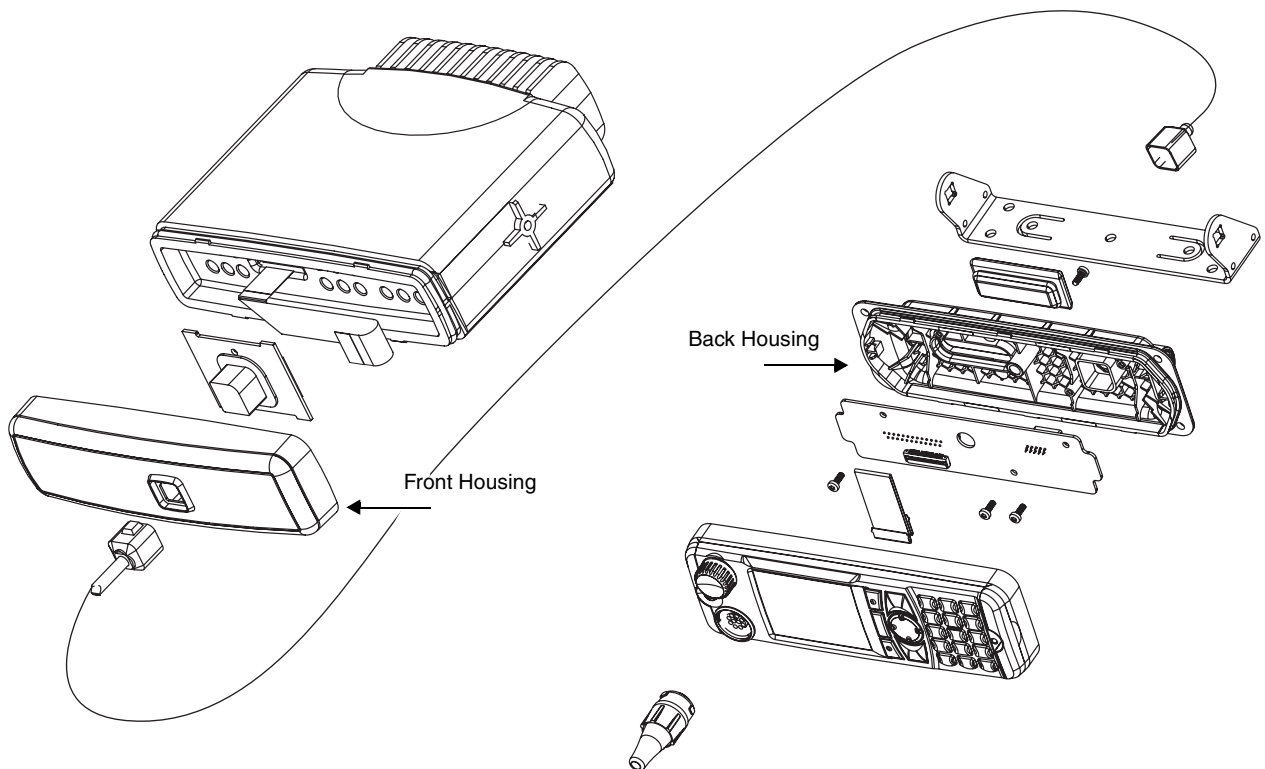

Figure 8 Remote Mount Head

Remote Mount Head - Reassembly

To Reassemble the Remote Front Housing:

1. Connect the flex from the Remote Front Housing to the top small connector in the Transceiver.

NOTE: For correct orientation of the flex in the Transceiver, the “plastic” tab should be up, contacts facing down. Align the ‘dot’ or ‘O’ marking on the flex with the ‘O’ mark on the Transceiver. The flex must be pushed into the connector until it meets the stop.

2. Press the Remote Front Housing onto the Transceiver chassis until the chassis tabs snap into place.

To Reassemble the Remote Back Housing

1. Connect the flex from the Remote Back PCB to the Control Head.

NOTE: For correct orientation of the flex align the ‘dot’ or ‘O’ marking on the flex with the ‘O’ mark on the PCB.

2. Depending on the arrangement, orientate the Control Head in the Back Housing
3. Press the Control Head onto the Remote Back Housing until **ALL** 6 tabs snap into place.

NOTE: The flex is not designed for continuous insertion, replace after several uses.

Expansion Head - Disassembly



CAUTION: The terminal must be disconnected from the power supply before commencing any disassembly. The Terminal Installation Manual should be referred to for more detailed information warnings and safety.

To Disassemble the Expansion Head from the Terminal

1. Remove the expansion head from the transceiver by inserting the dismantling tool (Part No. 6686119B01) in the recess between the expansion head and the transceiver.

NOTE: To minimize cosmetic damage disassemble from the bottom side, (label side).

2. Remove the two flexes from the terminal.

To Disassemble the Expansion Board from Expansion Head Housing

1. Remove the board from the expansion head housing by levering the expansion head housing and pulling up on the expansion board.

NOTE: The 40 pin connector has a top latch that needs to be lifted before the flex is inserted and closed after flex insertion.

2. Lift the top latch and remove the 40-Pin flex from connector board.

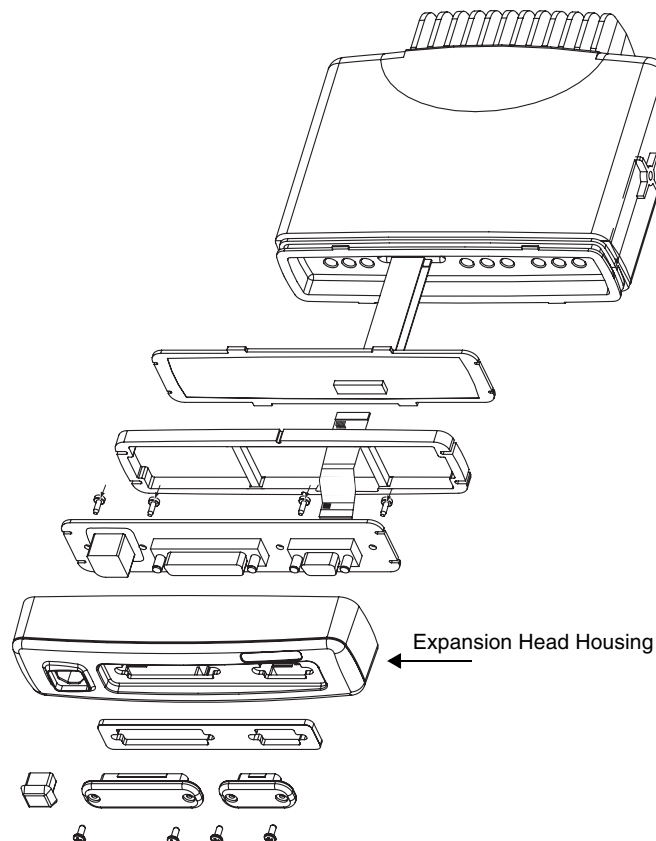

Figure 9 Expansion Head Exploded View

To Disassemble the Connector Board from Expansion Head Housing

1. Remove the silicon rubber frame
2. Remove the four screws from the connector board.
3. Remove all the protection caps on the front of the expansion head housing.
4. Lift the connector board from the expansion head housing.

Expansion Head - Reassembly

To Reassemble the Expansion Head

1. Insert the connector board into the expansion head housing.
2. Secure the connector board with the four screws previously removed.
3. Insert the rubber frame
4. Insert the 40 pin flex from the connector board to the Expansion board, ensuring that the top latch is firmly closed.
5. Snap the Expansion board into the expansion head housing
6. Connect the 12 line flex to the Terminal, top small connector.
7. Connect the 40 line flex to the Terminal, bottom large connector

NOTE: For correct orientation of the flex align the 'dot' or 'O' marking on the flex with the 'O' mark on the PCB.

8. Close the top latch after flex insertion
9. Push the expansion head housing onto the Transceiver until all 4 tabs snap firmly into place.
10. Connect modem cable and sophisticated remote mount Control Head (if applicable).

NOTE: The Expansion Head has a protection grade of IP54. To maintain IP54 sealing when connecting a RS232 data cable make sure to use a IP54 specified cable. (example: ROLINE AT-Modem cable ST-BU 1,8m order no. 11.01.4518)

NOTE: The flex is not designed for continuous insertion, replace after several uses.

Motorcycle Control Head - Disassembly

For disassembly of the Motorcycle version control head, use the following tools:
Parker's screwdriver, a pair of tweezers.

1. Unscrew the wing screws of the control head trunnion and remove the control head from the trunnion.
2. Unscrew the two screws that hold the connector bracket. Remove the bracket, the cable connector (not shown) and the gasket.
3. Unscrew the screws of the back housing and pull straight off.
4. The housing gasket may fall off when the back housing is removed. Note its location for reassembly. Refer to the exploded view for positioning.
5. The lock plate is aligned with one of the housing sides. Slide the lock plate the other direction and lift straight off. Note its placement for reassembly.
6. Remove the PCB support.
7. Carefully lift PCB board assembly out holding the socket of the connector for the flexible PCB.
8. Remove the Insert from the Light Guide.
9. Unscrew all the screws of the Light Guide and carefully lift it out. This step is only required to gain access to the keypad.
10. With the light guide removed, the keypad can be pulled from the front housing. Take care not to touch or get contaminants on the conductive pads on the underside of the keypad.
11. Remove the Internal Spacer using a pair of tweezers. From inside the control head carefully press in two of the tabs of the Volume Knob so that the tabs deflect out and disengage from the control head Housing. Pull the Volume Knob straight out.
12. The External Spacer may fall out. Note its location for reassembly. Refer to the exploded view for positioning.

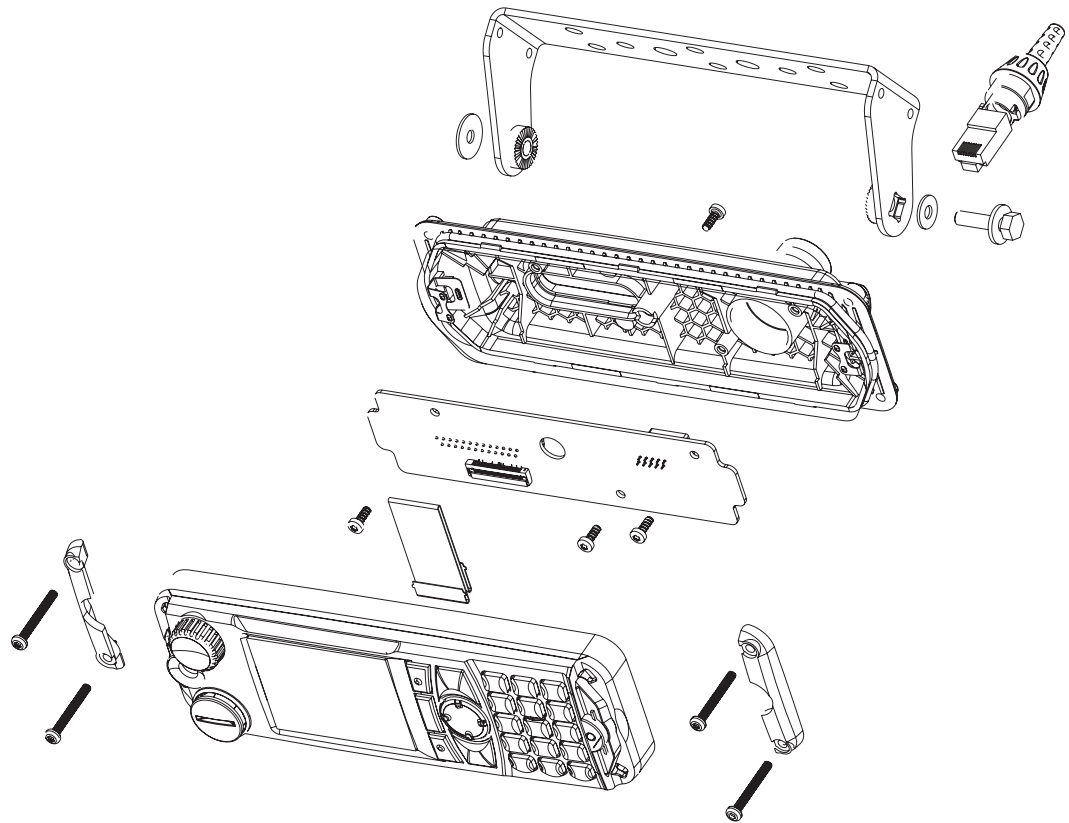

Figure 10 Motorcycle Control Head Exploded View

Motorcycle Control Head - Reassembly

1. Place the volume knob assembly into the opening.
2. Place the keypad into the front housing.
3. Place the light guide into the housing and fasten it with the screws. Be sure that all screws are fastened properly.
4. Make sure that both the volume knob and potentiometer are in the fully counterclockwise position before inserting the board assembly into the front housing.
5. Snap the board assembly into the front housing and verify that the volume knob turns clockwise and counterclockwise, and that when you push on it, it sounds a sound.
6. Place the PCB support - see the exploded view for proper direction.
7. Slide the Lock Plate into place.
8. Install the black gasket into the back housing and fasten the back housing to the front housing with the screws.
9. Place the gasket, insert the cable connector and mount the connector bracket with the screws.

NOTE: Use only the black gasket (Mot.Part.No. 3202113U01) to achieve full IP 57 protection

Service Aids

The following table lists the service aids recommended for working on the terminal. While all of these items are available from Motorola, most are standard workshop equipment items, and any equivalent item capable of the same performance may be substituted for the item listed.

Table 19 Service Aids

Motorola Part No.	Description	Application
6666500A01	Housing Eliminator	Test Fixture used to bench test the terminal pcb
6686119B01	Dismantling Tool	Assists in the removal of terminal control head
0180320B16	Torx Screw Driver Kit (T6,8,10,15,25)	
6680321B81	Torx Bit	
6680321B56	Insert Bit extra long	
T-20 TORX (or equivalent)	Screwdriver with torque meter	

EXPLODED VIEWS & PARTS LISTS

NOTE: For optimum performance, all replacement parts, diodes, transistors and integrated circuits must be ordered by Motorola part numbers.

Transceiver - Exploded View and Parts List

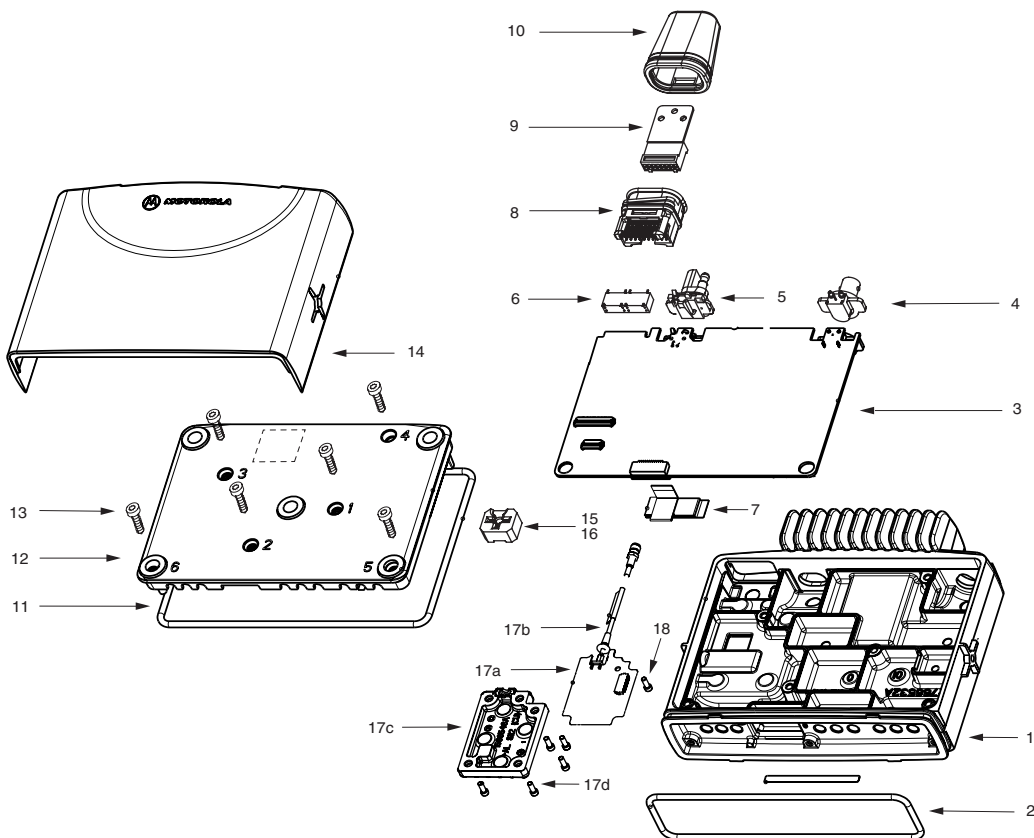

Figure 11 Transceiver Exploded View

NOTE: Terminals with special label **OPTION BOARD MOUNTED** (see dotted lines on figure above) are equipped with an additional board inside the transceiver cover plate. Refer to the figure next page before disassembling such terminals.

Table 20 Transceiver Parts List

Item No.	Description	Part Number
1	Chassis (item 2 included)	2766532A01
2	Gasket, Control Head	3202620Y01
3	Main PCB (items 4 - 7 included)	refer to Appendix: Service Kits
4	BNC Antenna Connector	0986166B01
5	Power Connector	0986165B01

Table 20 Transceiver Parts List

Item No.	Description	Part Number
6	Accessory Connector	0986105B01
7	Flex to optional GPS	3066541B01
8	Connector Assembly	2886122B02
9	Connector Housing 16Pos.	1580922V01
10	Gasket Accessory Connector	3202606Y02
11	Gasket Cover	3286095B01
12	Cover	1566511A02
13	Screw T20, 6x (M4)	0310911A30
14	Cover, Plastic	1586170B01
15	Silicon Pressurepad for UHF only	7566500A01
16	Silicon Pressurepad for 800MHz only	7566502A01
17	GPS Module Kit:	0166502N65
	17a GPS Board with flex	0166502N20
	17b Coax Cable	3366540B01
	17c GPS Cover	1566548A01
	17d Screw, 5x (M3x8)	0310907A19
18	Screw for GPS board, 1x (M3x8)	0310907A19
19	Bushing for IP 54 Protection w/o GPS (not shown)	4366504A02
20	UCM Board Kit:	GMLN4210_
	20a UCM Board Module	CLN8041_
	20b UCM Board Cover	0786183B01
	20c UCM Board Flex	8485615Z02
	20d Screw 3x (M5x8)	0310943R55

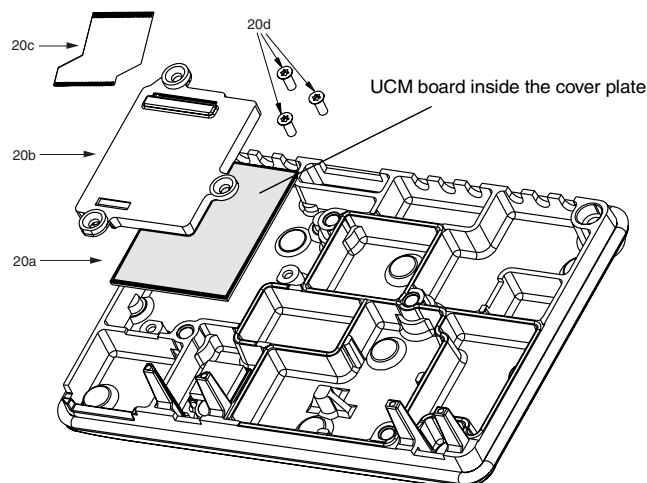
**Figure 12** Location of additional UCM Board inside the Cover Plate

CAUTION: There is a flex installed connecting the UCM board to the main board. Take extra care not to tear off the flex when dis-assembling or re-assembling the board from/to the transceiver cover plate or this could damage the UCM board and the main board.

NOTE: The CLN8041_ UCM board is not repairable. Order a replacement board if necessary.

Enhanced Control Head - Exploded View and Parts List

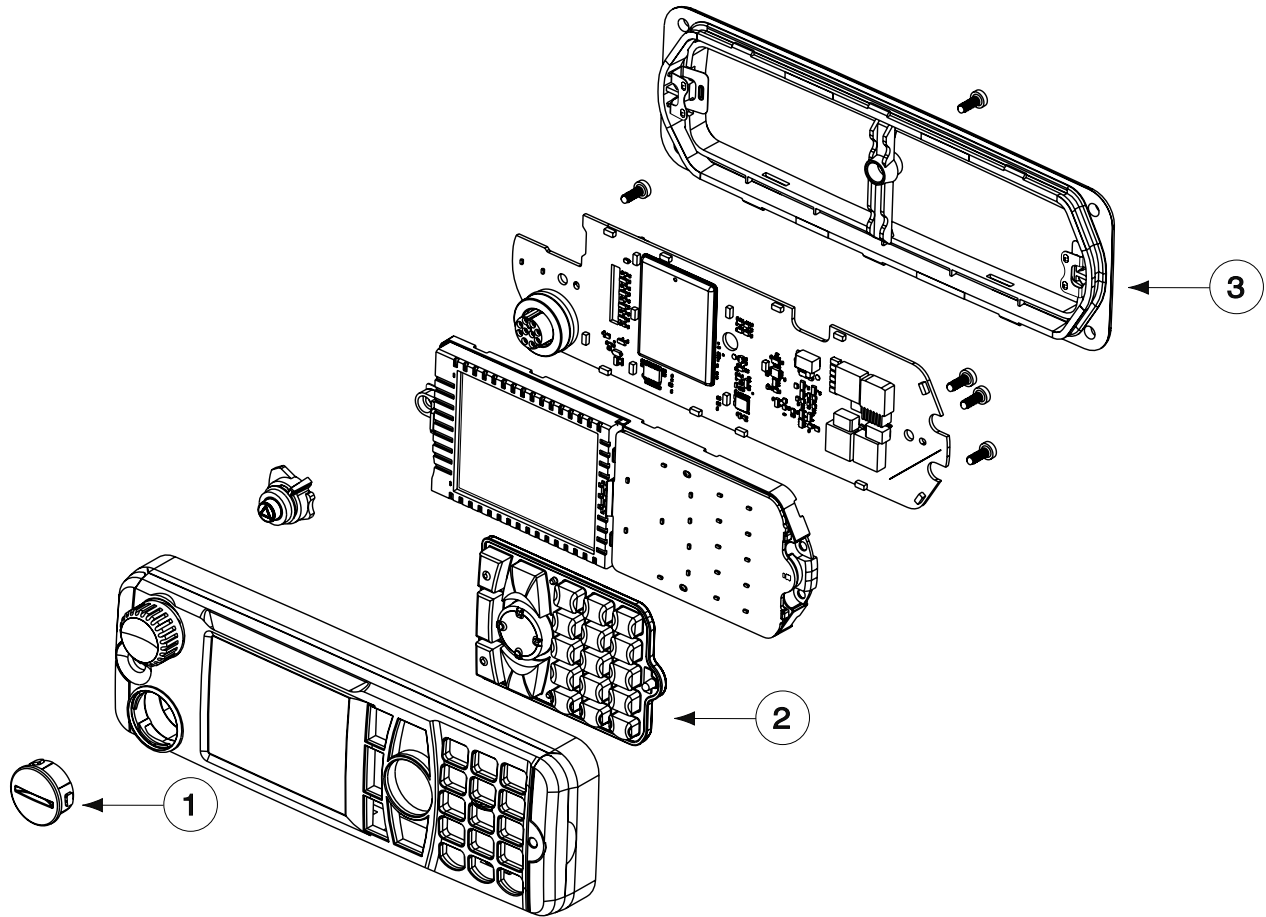

Figure 13 Enhanced Control Head - Exploded View 1

Table 21 Enhanced Control Head - Parts List 1

Item No	Description	Part No
1	GCAI Cover	1515048C01
2	KeyPad Assy	7571017L01
3	Head Bridge Assy	0104025J29

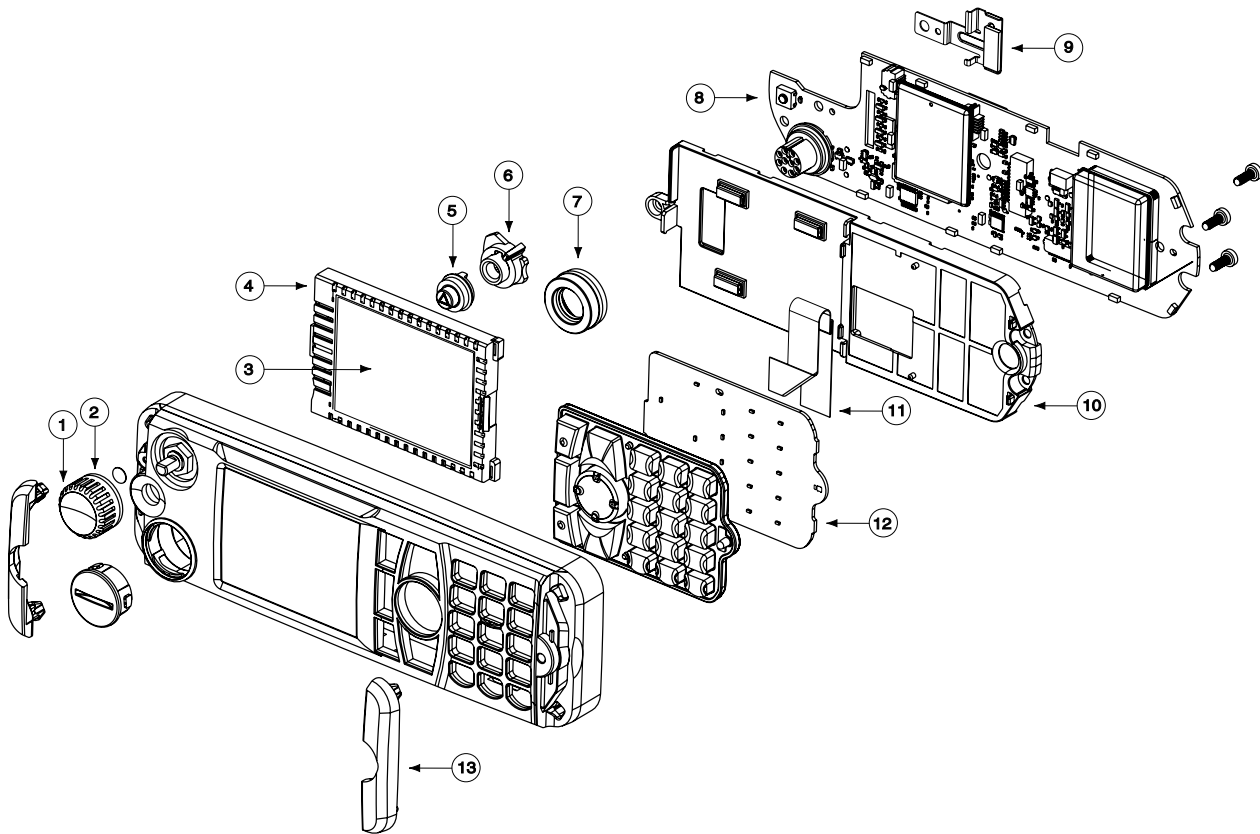

Figure 14 Enhanced Control Head - Exploded View 2

Table 22 Enhanced Control Head - Parts List 2

Item No	Description	Part No
1	Encoder Knob	3616898H01
2	Gore Port	3205472M02
3	LCD Module	7271138D01
4	LCD Rubber Jacket	7516954H01
5a	Emergency Key	3816953H01
6	Emergency Key Frame	0716944H01
7	GCAI Seal	3264133H01
8	Main PWA Kit	GMLN4312A
9	LCD Metal Retainer	4216900H01
10	Chassis	2716937H01
11	KeyPad FFC	8471919L01
12	KeyPad PWA Kit	GMLN4311A
13	Side Cap	3816950H01

Expansion Head - Exploded View and Parts List

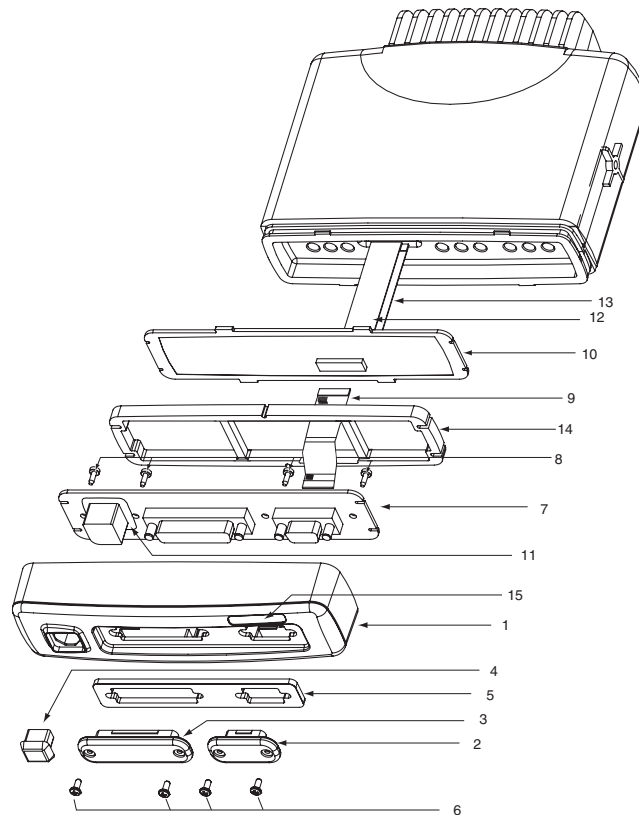

Figure 15 Expansion Head - Exploded View

Table 23 Expansion Head - Parts List

Item No	Description	Part No
1	Expansion Head Housing	1564290B01
2	Cover 9 Sub-D	3864326B01
3	Cover 25 Sub-D	3864326B02
4	Protection Caps/Bung, Telco	GLN7306_
5	Seal, Expansion Head	3264325B01
6	Screw, Protection Caps/Bung (4 required)	0305137Q02
7	Connector Board	PMLN5087A
8	Screw, Connector PCB (4 required)	0385944A02
9	Flex 40 Pin	8415157H01
10	Expansion Board, not part of Housing Kit	PMLN4939A
11	Seal for 10 Pin Telco on PCB	3264291B01
12	Flex 12 Pin	8486127B01
13	Flex 40Pin	8466543A01
14	Silicone Pressure Pad	3264337B01
15	Label	5464344B07

Remote Mount - Exploded View and Parts List

Figure 16 Remote Mount - Exploded View

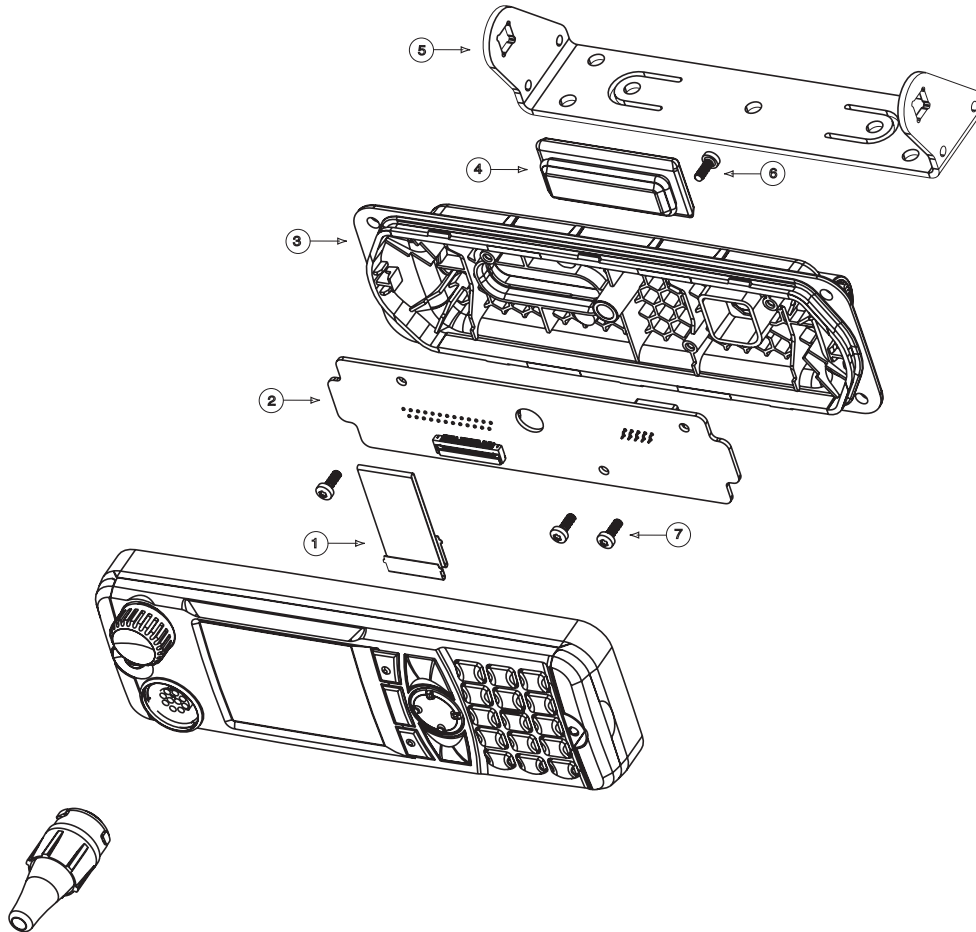

Table 24 Remote Mount - Parts List

Item No.	Description	Part No.
1	Side FFC (Main to Remote)	8471921L01
2	Remote PWA Kit	GMLN4310A
3	Remote Back Hsg Assy	0104025J30
4	D Sub Cover	1571012L01
5	Trunnion	0716933H01
6	Middle Screw	0371912L01
7	Self Tapping Screw	0316961H01

Remote Mount Kit - Exploded View and Parts List

Figure 17 Remote Mount Head - Exploded View

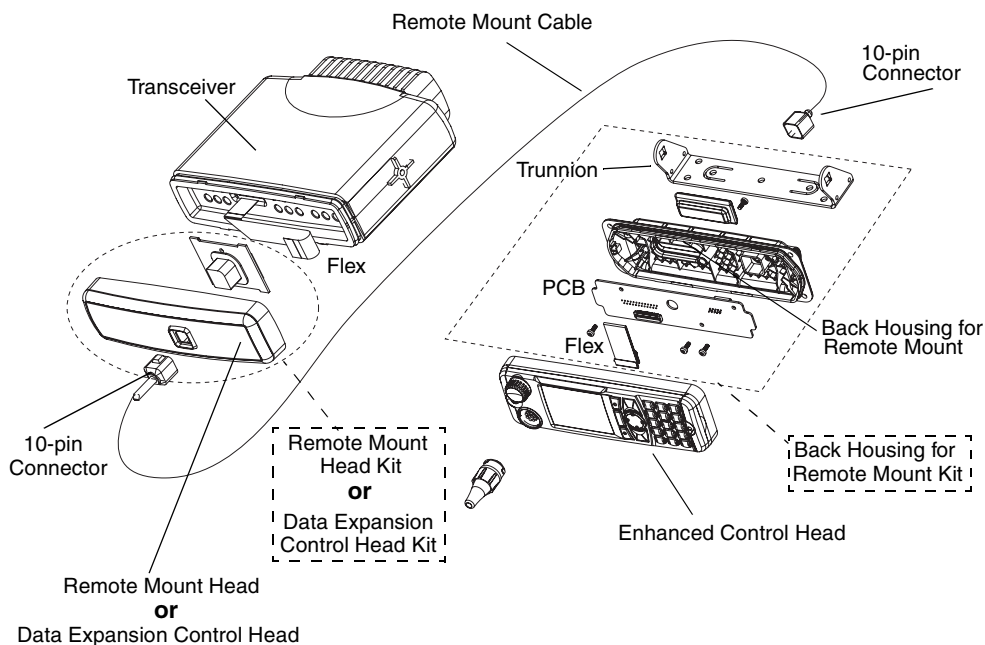

Table 25: Associated Components Remote Mount Kit

Description		Part Number
Remote Mount, 3 m		
	Remote Mount Head Kit	PMLN4904_
	Remote Mount Cable, 3 m	RKN4077_
	Speaker Extension Cable	GMKN4084_
Remote Mount, 5 m		PMLN4493_
	Remote Mount Head Kit	PMLN4904_
	Remote Mount Cable, 5 m, shielded	RKN4078_
	Speaker Extension Cable	GMKN4084_
Remote Mount, 7 m		PMLN4494_
	Remote Mount Head Kit	PMLN4904_
	Remote Mount Cable, 7 m	RKN4079_
	Speaker Extension Cable	GMKN4084_
Remote Mount, 10 m		PMLN4494_
	Remote Mount Head Kit	PMLN4904_
	Remote Mount Cable, 10 m	PMKN4020_
	Speaker Extension Cable	GMKN4084_

Table 26: Associated Components Remote Mount Expansion Kit

Description		Part Number
Remote Mount Expansion, 3 m		
	Data Expansion Control Head Kit	PMLN4908_
	Remote Mount Cable, 3 m	RKN4077_
	Speaker Extension Cable	GMKN4084_
Remote Mount Expansion, 5 m		PMLN4493_
	Data Expansion Control Head Kit	PMLN4908_
	Remote Mount Cable, 5 m	RKN4078_
	Speaker Extension Cable	GMKN4084_
Remote Mount Expansion, 7 m		PMLN4494_
	Data Expansion Control Head Kit	PMLN4908_
	Remote Mount Cable, 7 m	RKN4079_
	Speaker Extension Cable	GMKN4084_
Remote Mount Expansion, 10 m		PMLN4494_
	Data Expansion Control Head Kit	PMLN4908_
	Remote Mount Cable, 10 m	PMKN4020_
	Speaker Extension Cable	GMKN4084_

Motorcycle Control Head - Exploded View and Parts List

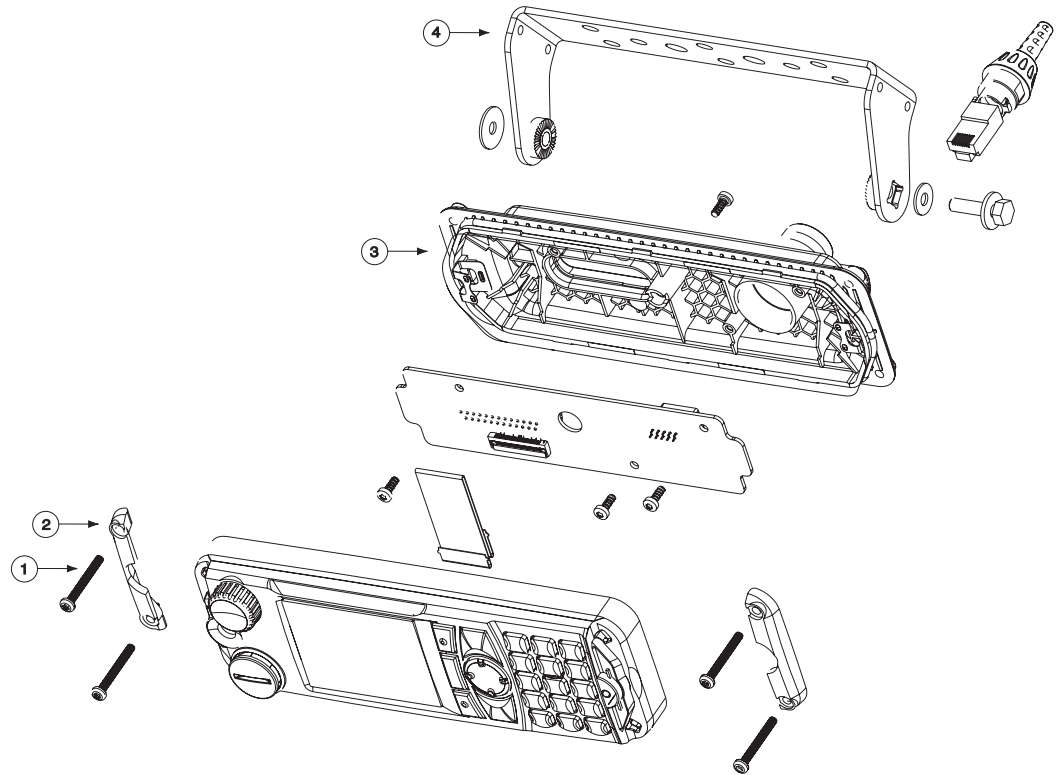

Figure 18 Motorcycle Control Head - Exploded View

Table 27 Motorcycle Control Head - Parts List

Item No.	Description	Part No.
1	Side Cap Screw	0316960H02
2	MC Side Cap	3871547L01
3	MC Back Hsg Assy	0104025J31
4	MC trunnion	0771445L01

THIS PAGE INTENTIONALLY LEFT BLANK

CHAPTER 8

SCHEMATICS, PCBs AND PARTS LISTS



Any level 3 repairs can deeply affect the performance of the MTM800 ENH terminal and may cause a new tuning procedure. This tuning procedure can only be applied by certain authorized Motorola depots where the appropriate TEST&TUNE EQUIPMENT is available. The appropriate TEST&TUNE EQUIPMENT is a special automated test equipment which is only available at some Motorola factories and Motorola repair centres.

Section Introduction

This Chapter contains the following Sections:

- 8.1 Transceiver 806-870MHz: Schematics/PCBs and Parts Lists**
- 8.2 Control Heads:** Enhanced Control Head
Expansion Head
Remote Mount Head
Motorcycle Control Head

NOTE: For optimum performance, all replacement parts, diodes, transistors and integrated circuits must be ordered by MOTOROLA part numbers.

THIS PAGE INTENTIONALLY LEFT BLANK

CHAPTER 8.1

TRANSCEIVER: SCHEMATICS, PCBs AND PARTS LISTS

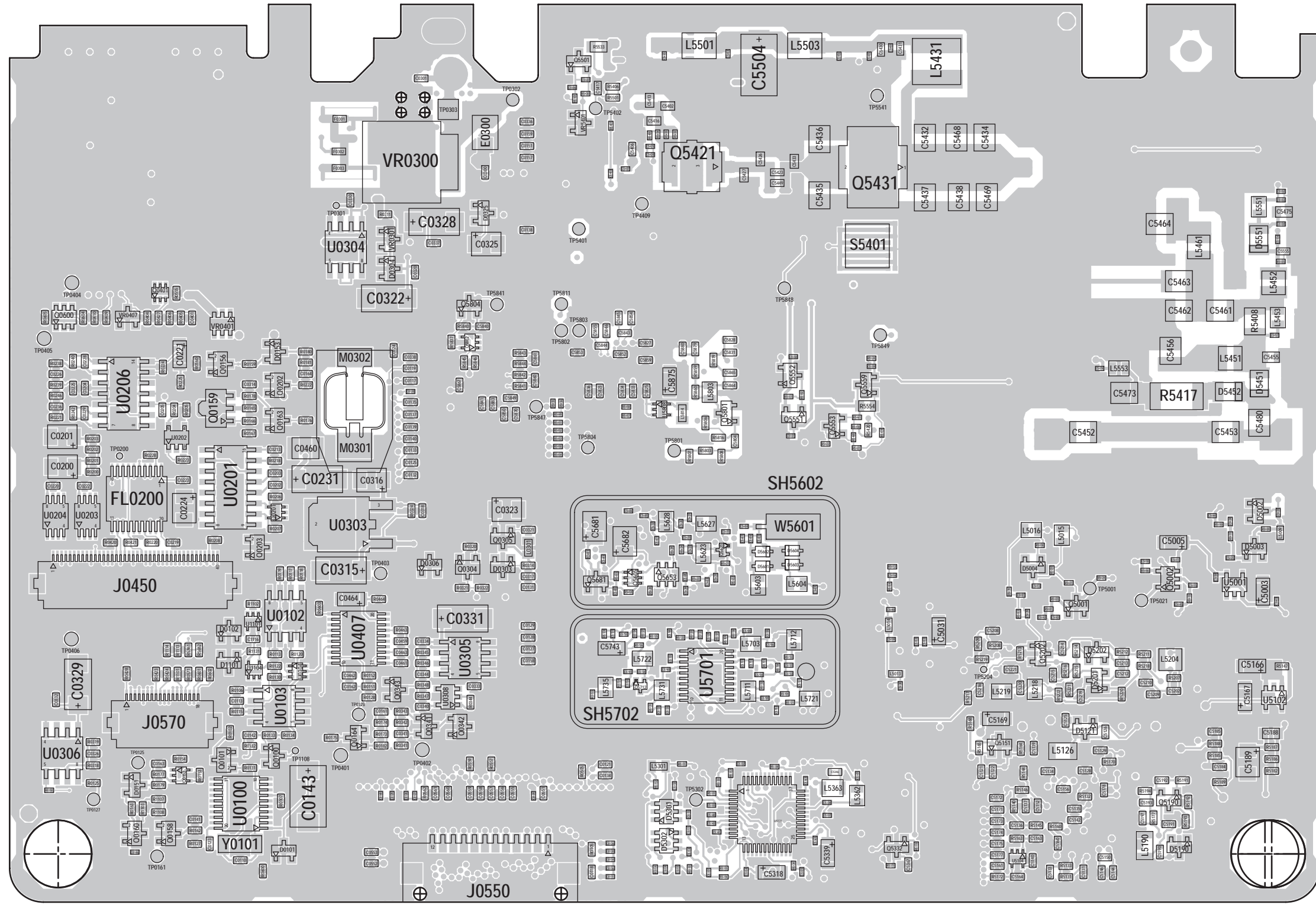

PCB / Main Board 8466582A02_B / BOT SIDE

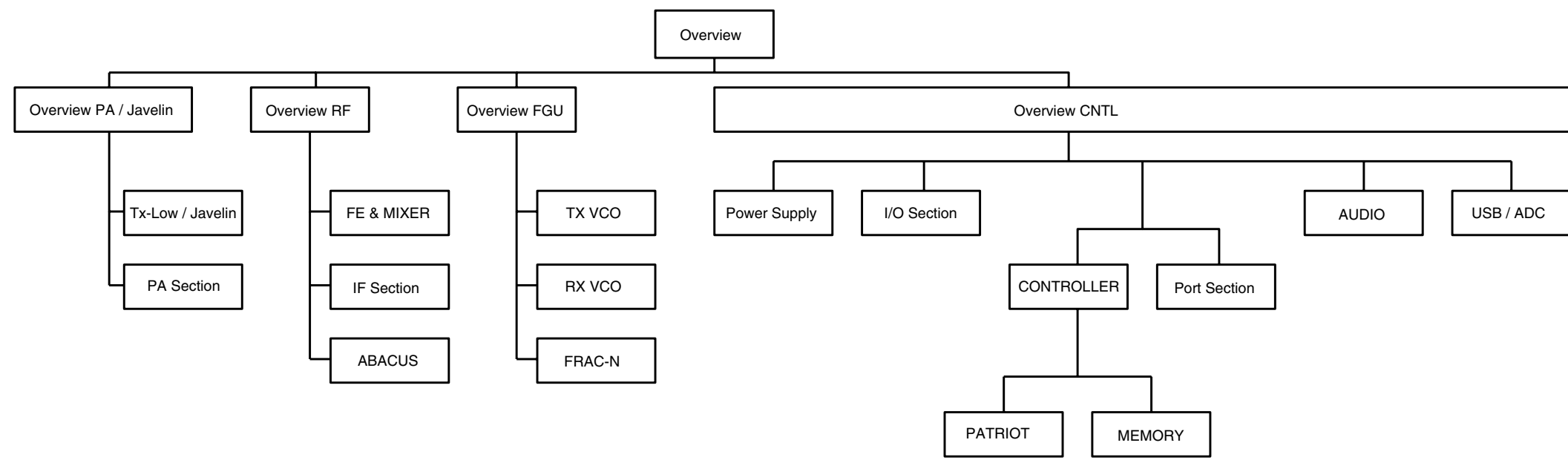
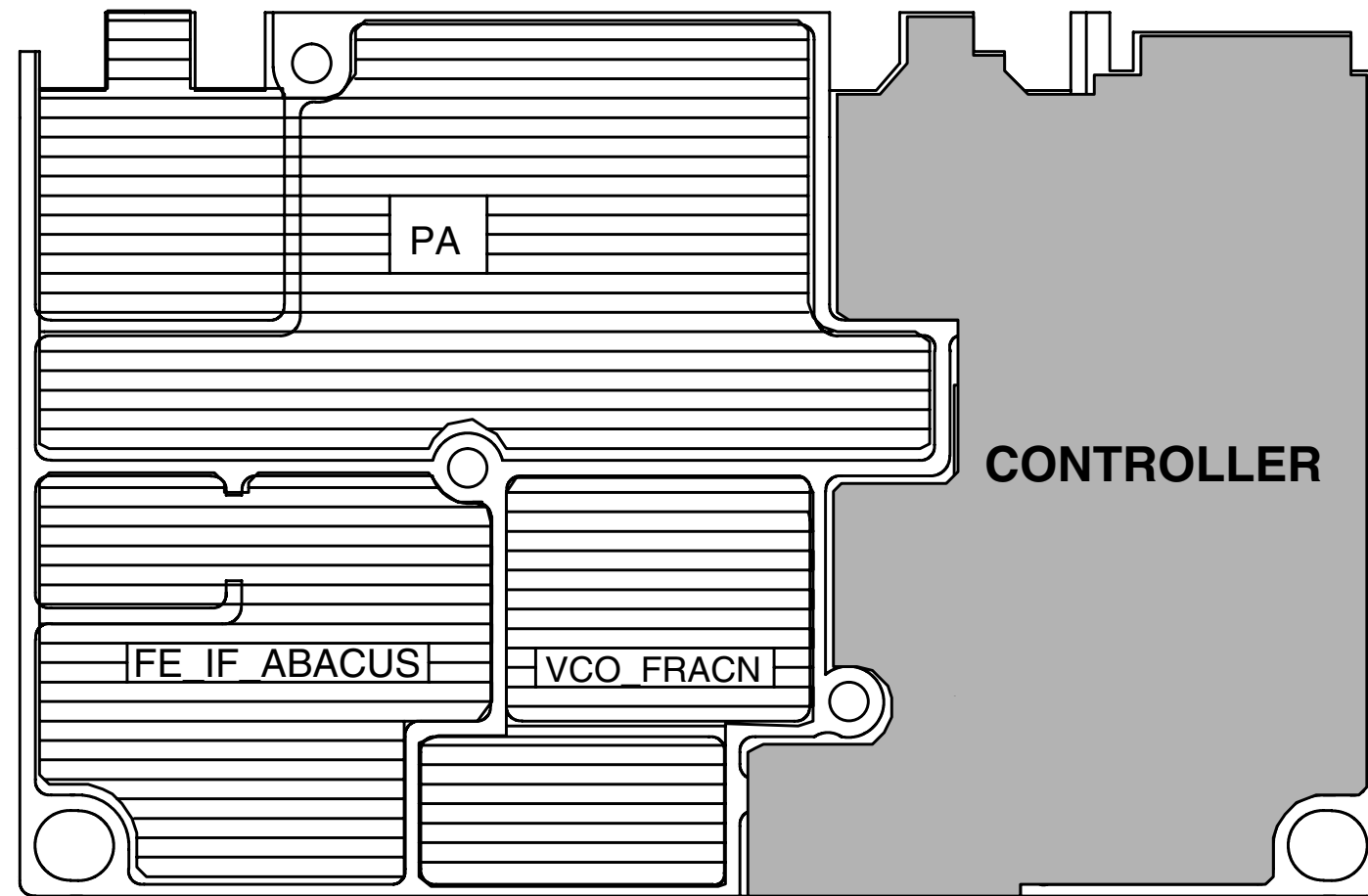

TRANSCEIVER OVERVIEW

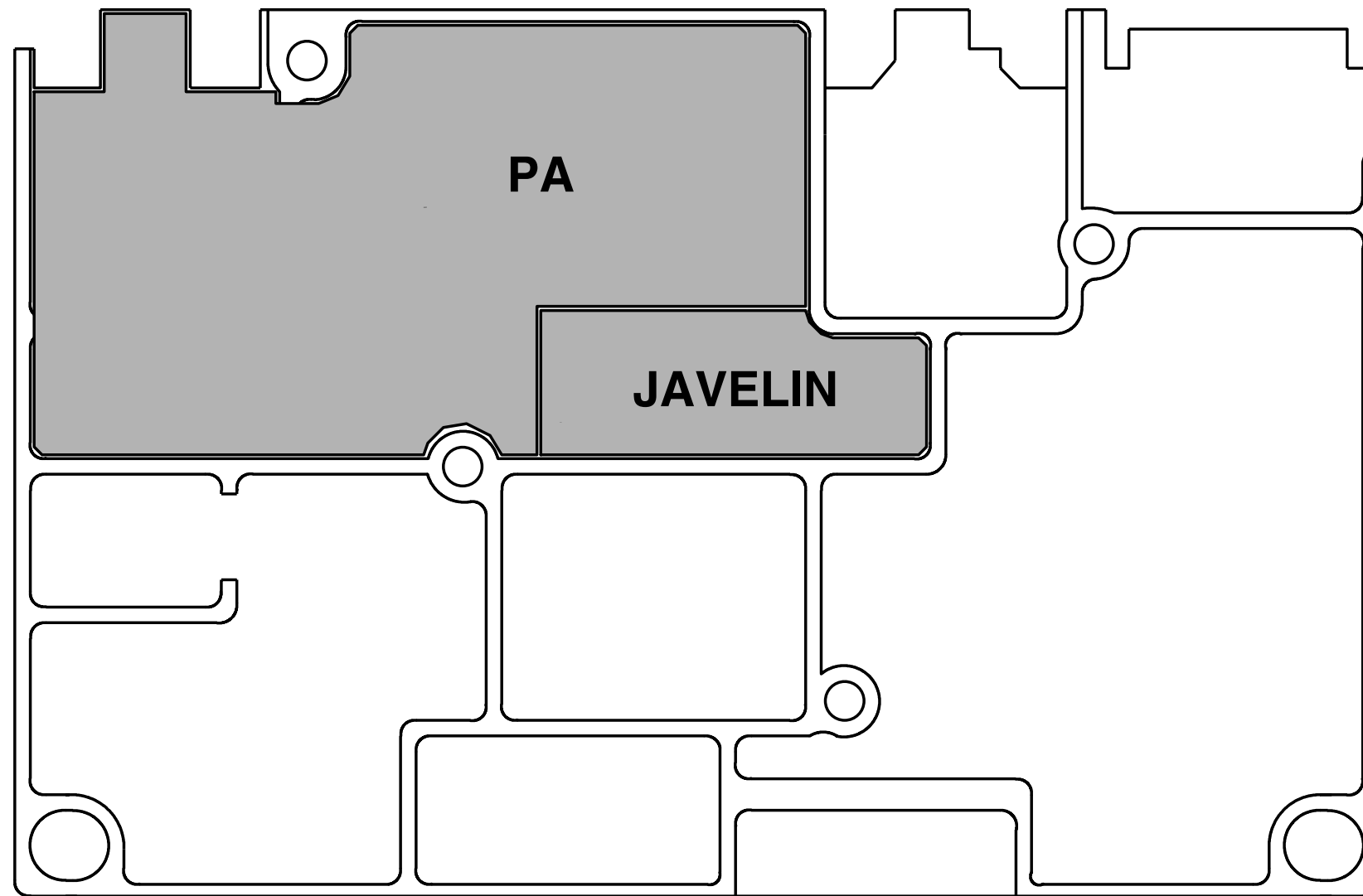

Main Board 8466582A02_B / PA & JAVELIN section

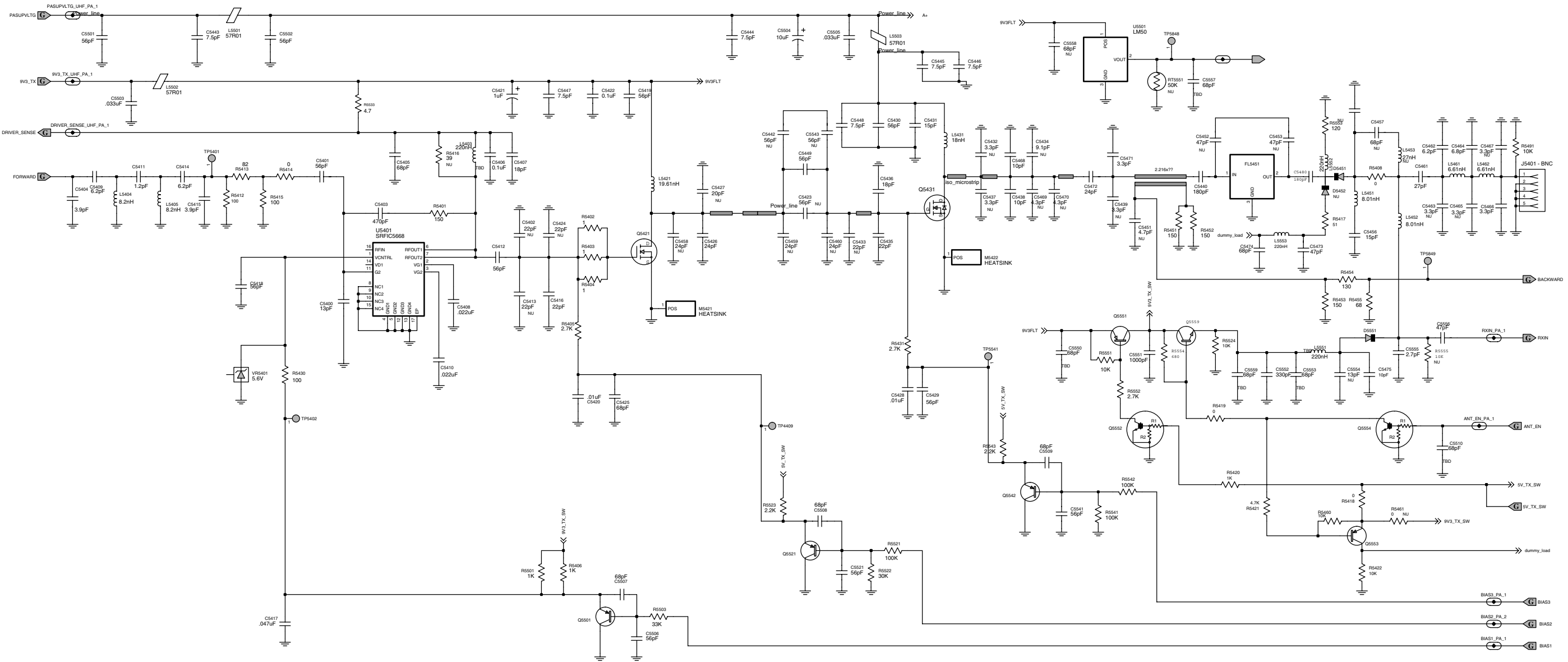

Main Board 8466582A02_B / PA 800MHz

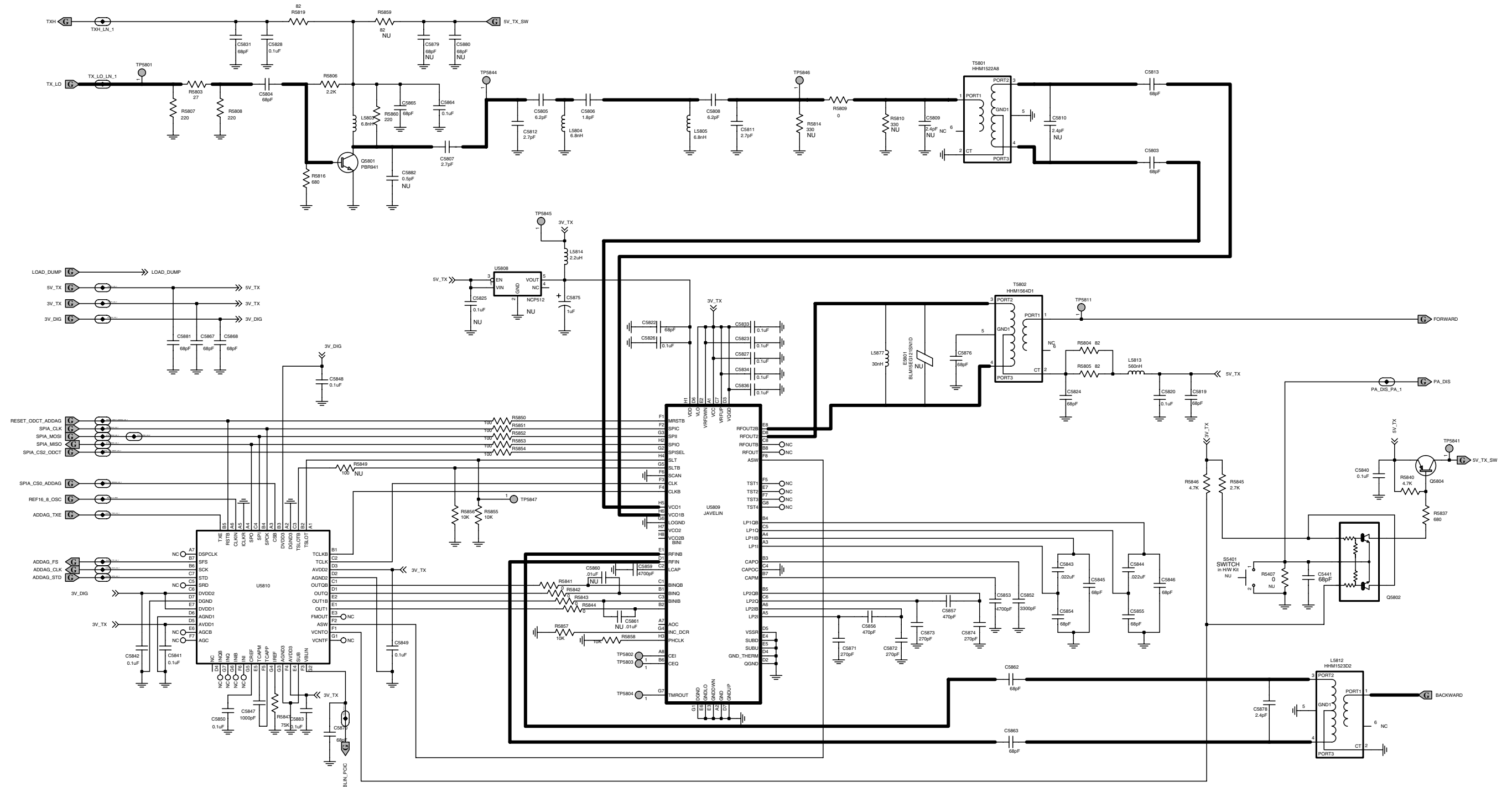

Main Board 8466582A02_B / TX-LOW SECTION_JAVELIN

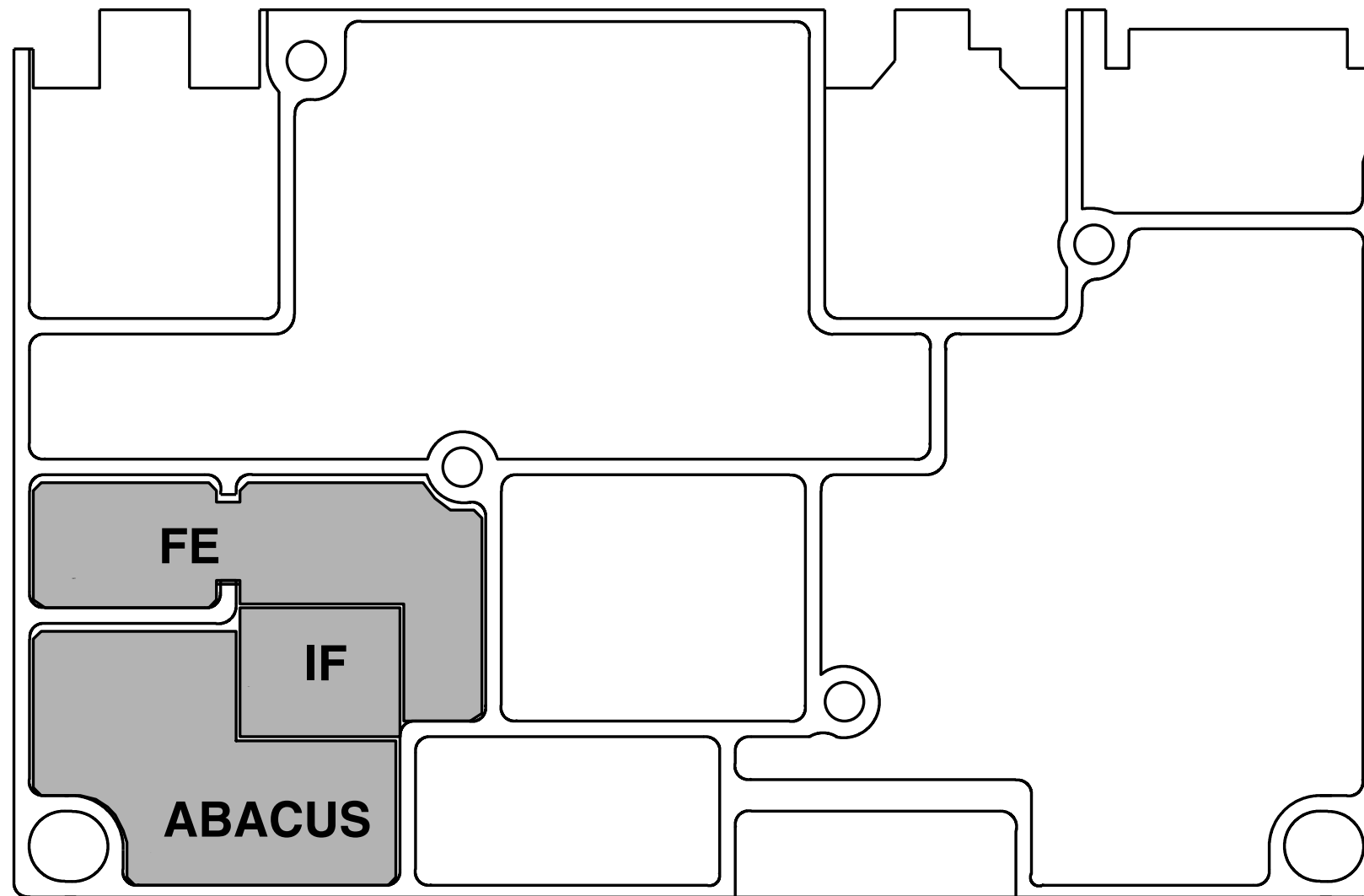

Main Board 8466582A02_B / RF overview

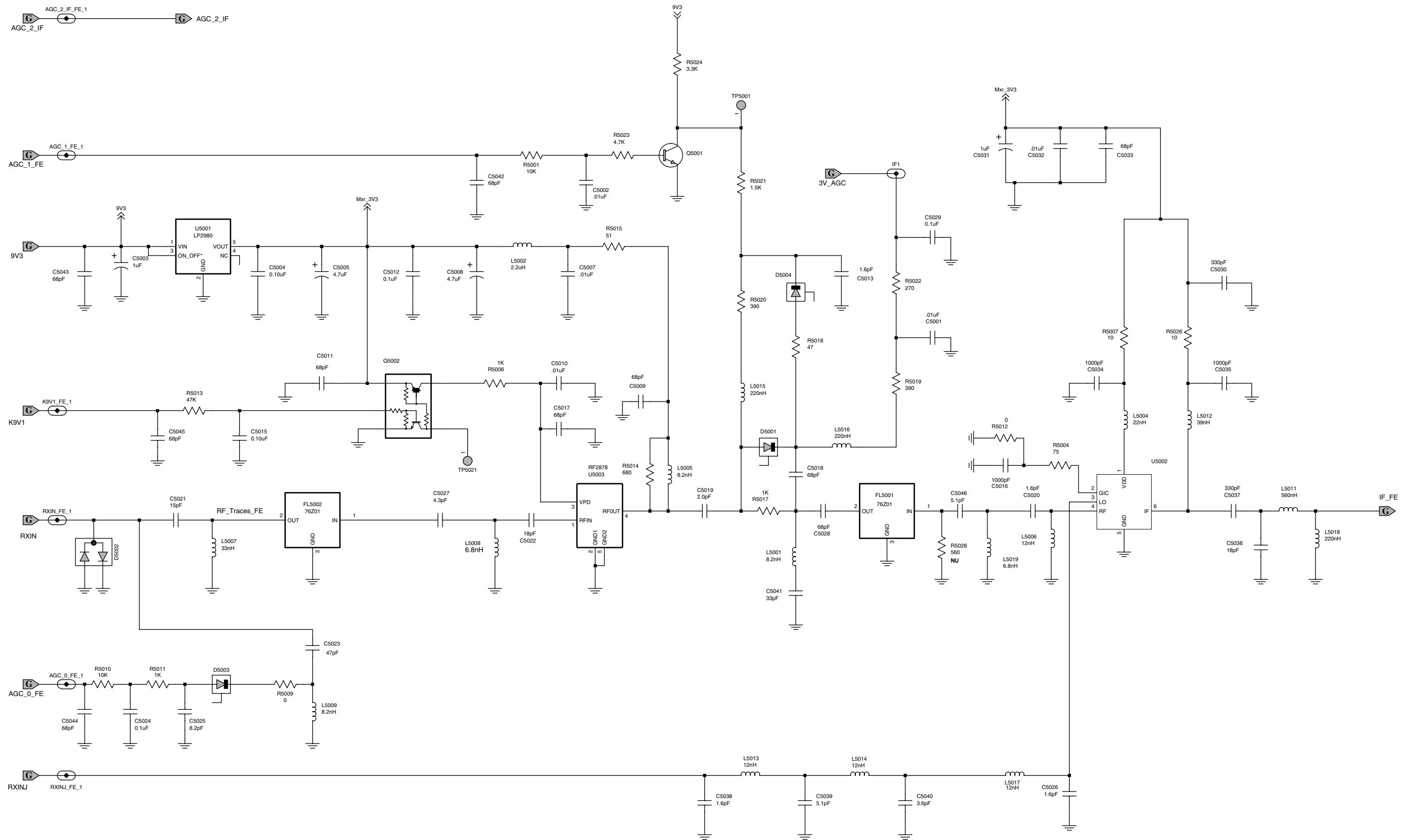

Main Board 8466582A02_B / FE and Mixer Section

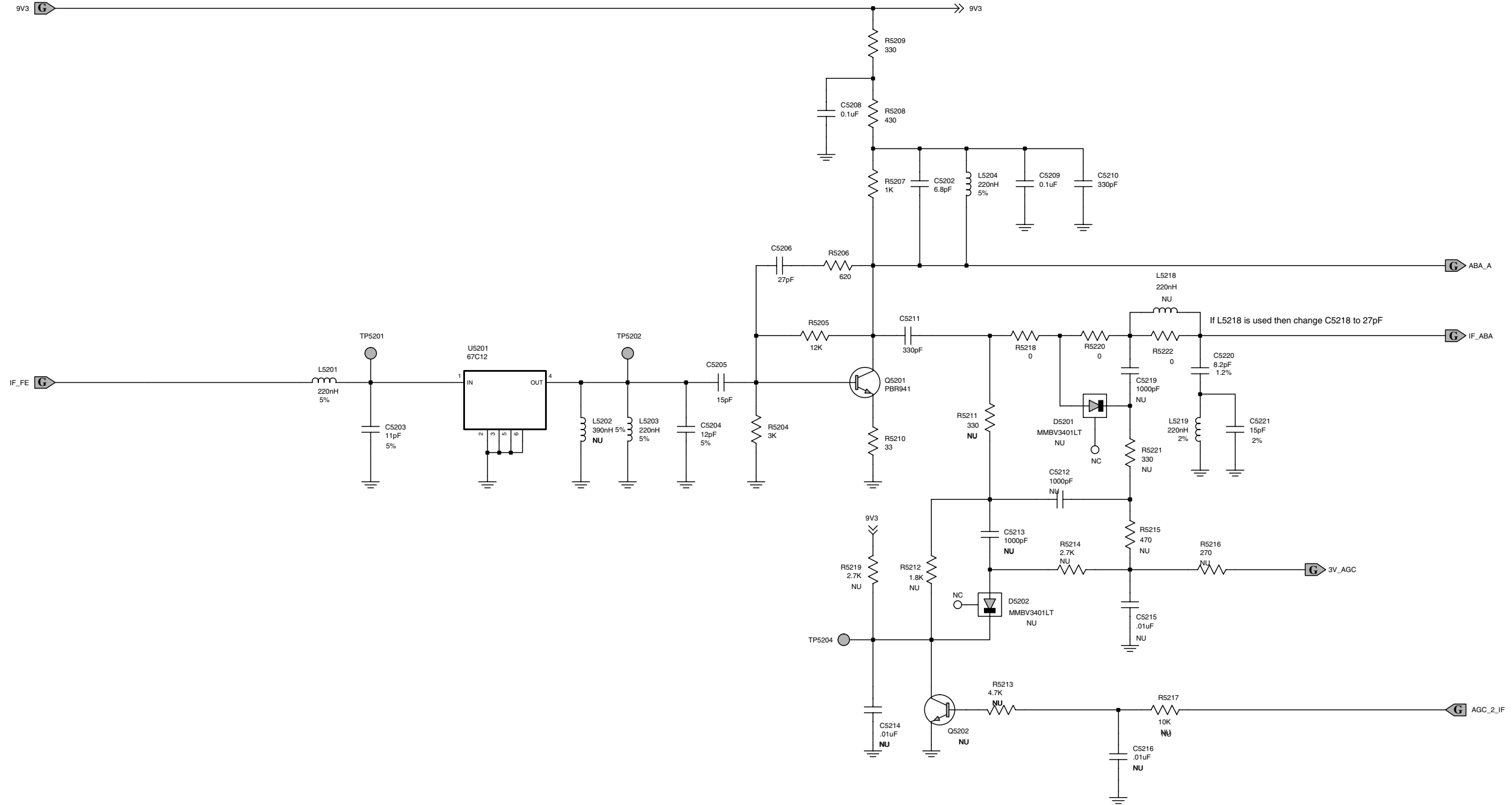

Main Board 8466582A02_B / IF Section

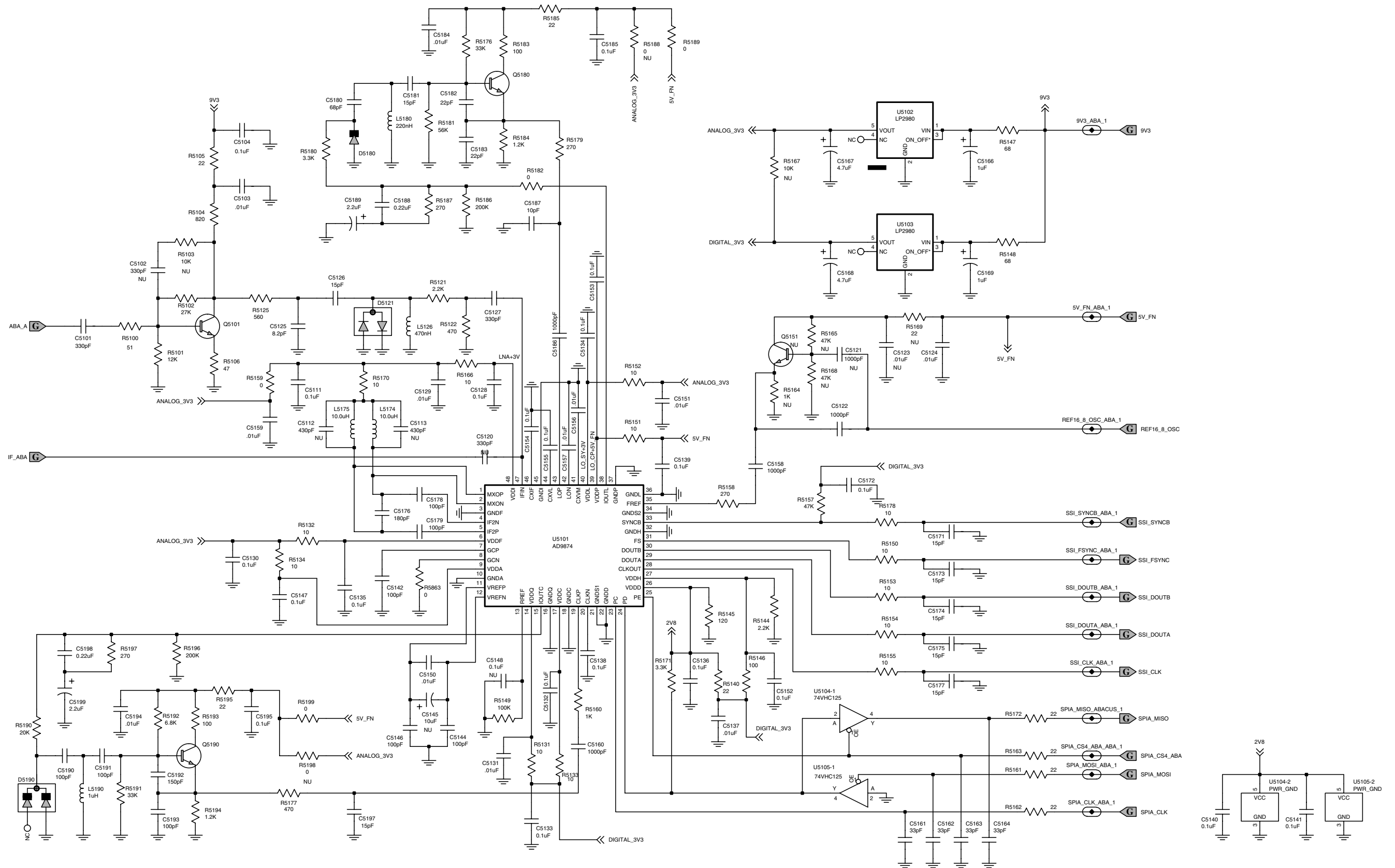

Main Board 846582A02_B / ABACUS Section

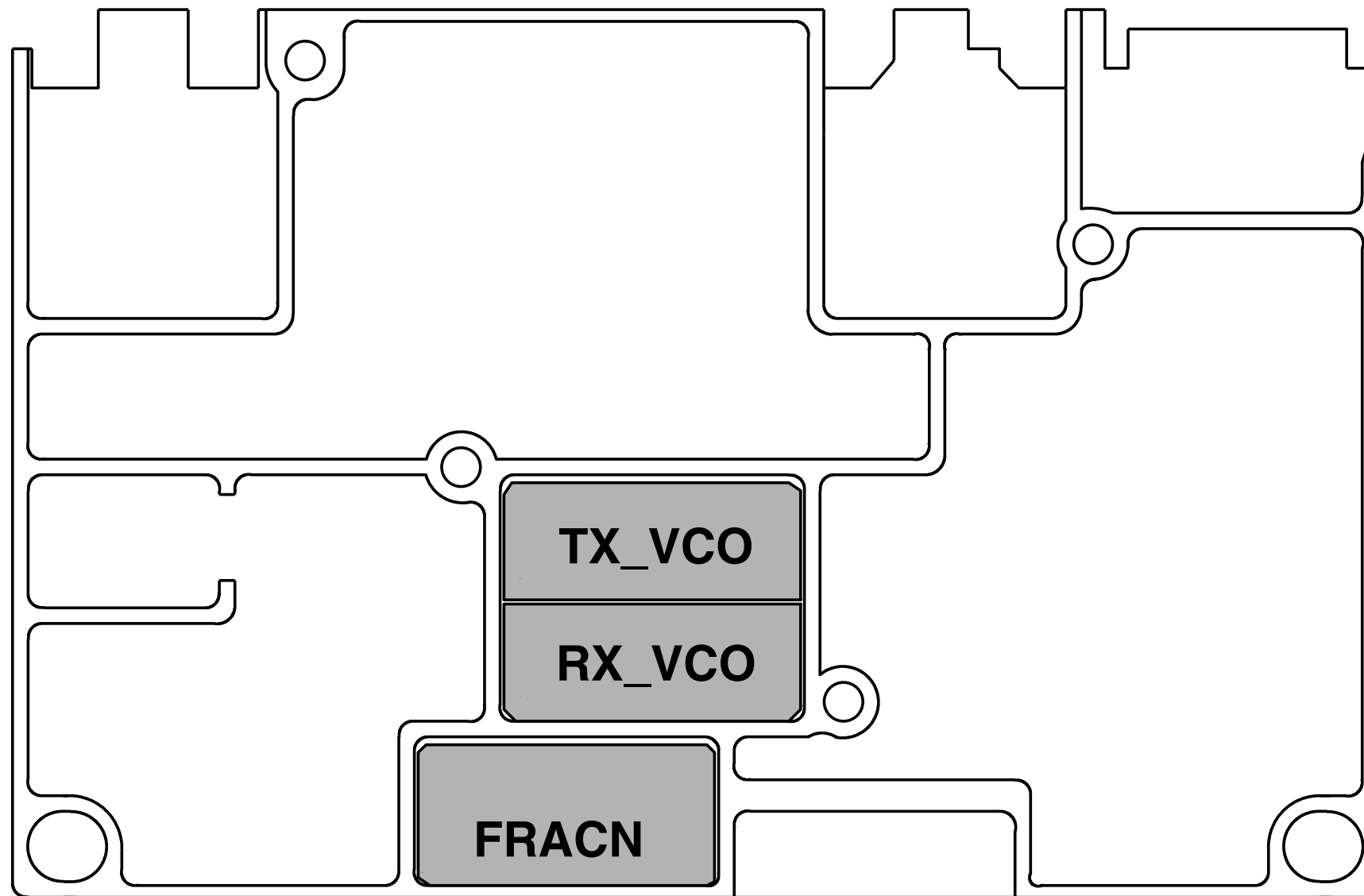

Main Board 8466582A02_B / FGU overview

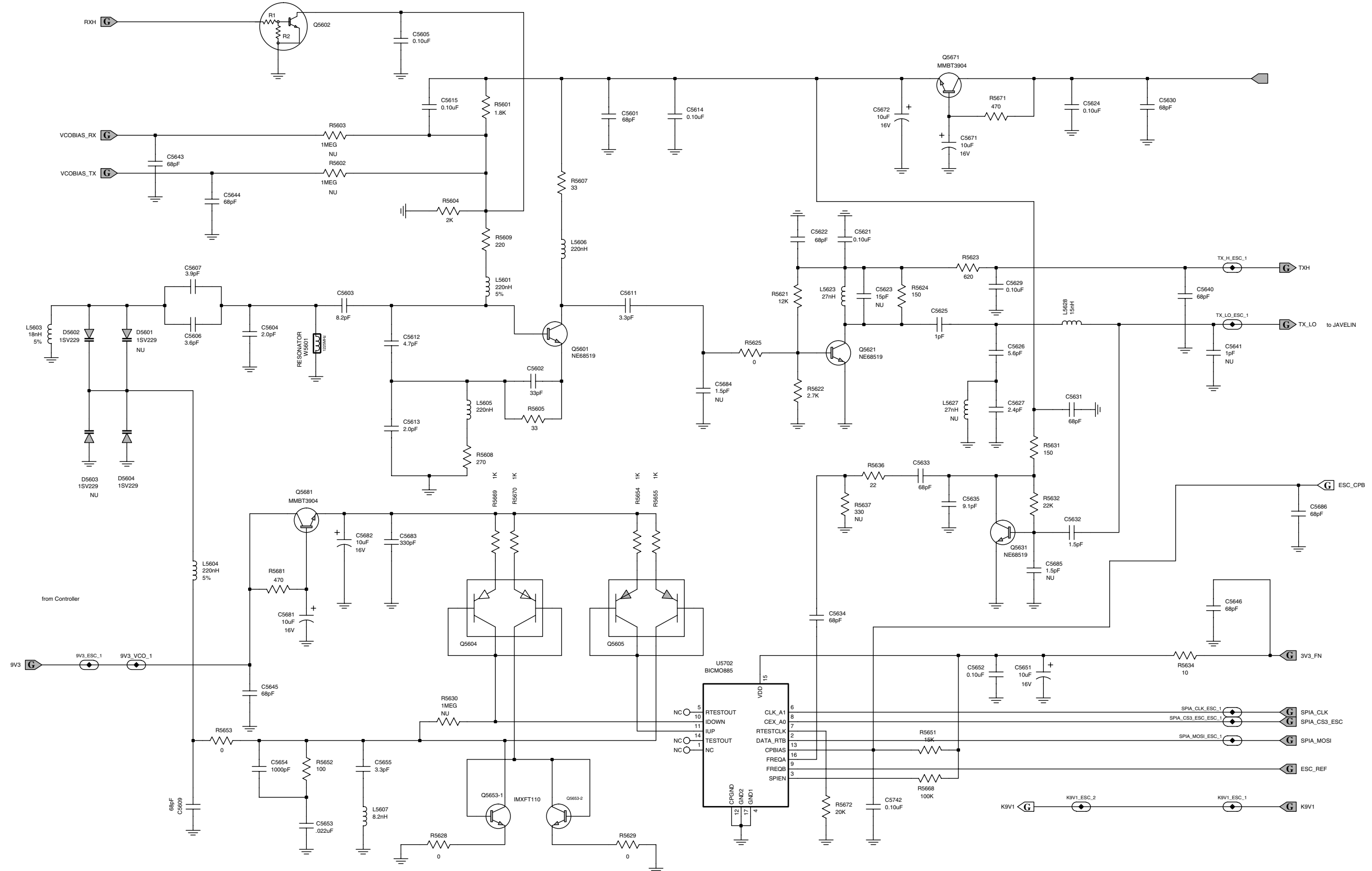

Main Board 8466582A02_B / TX-VCO Section

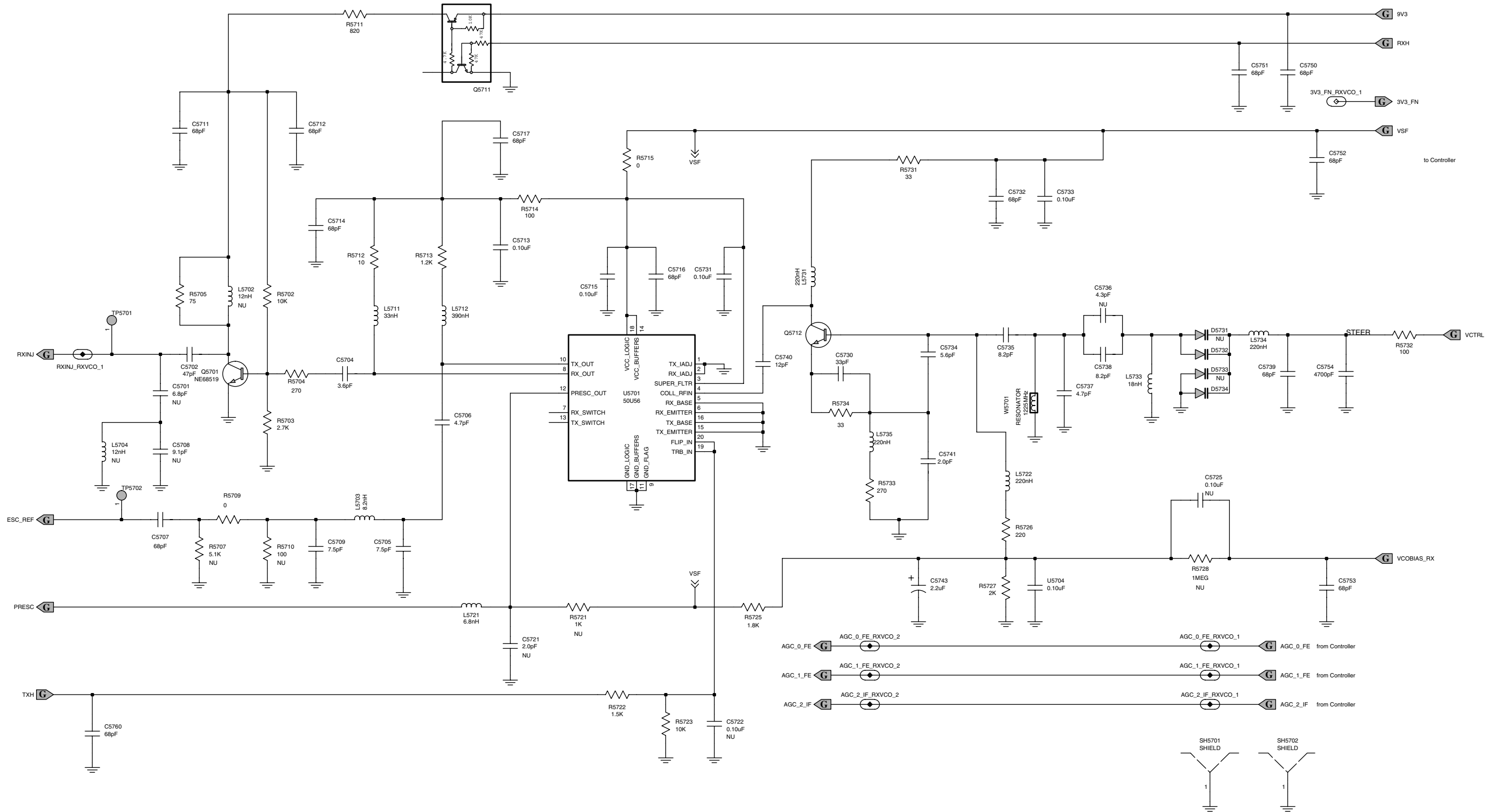

Main Board 8466582A02_B / RX-VCO Section

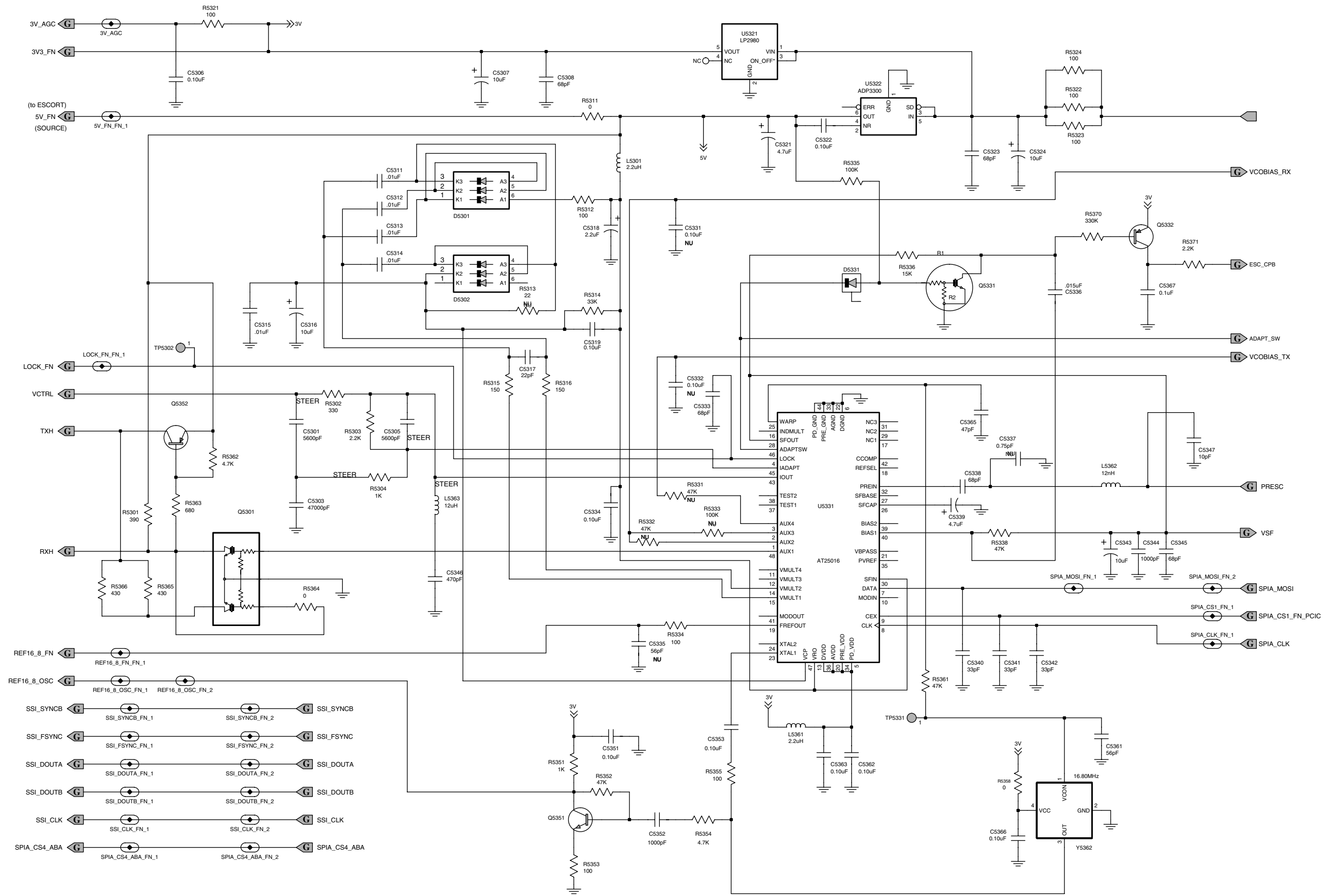

Main Board 8466582A02_B / Controller Power Supply Section

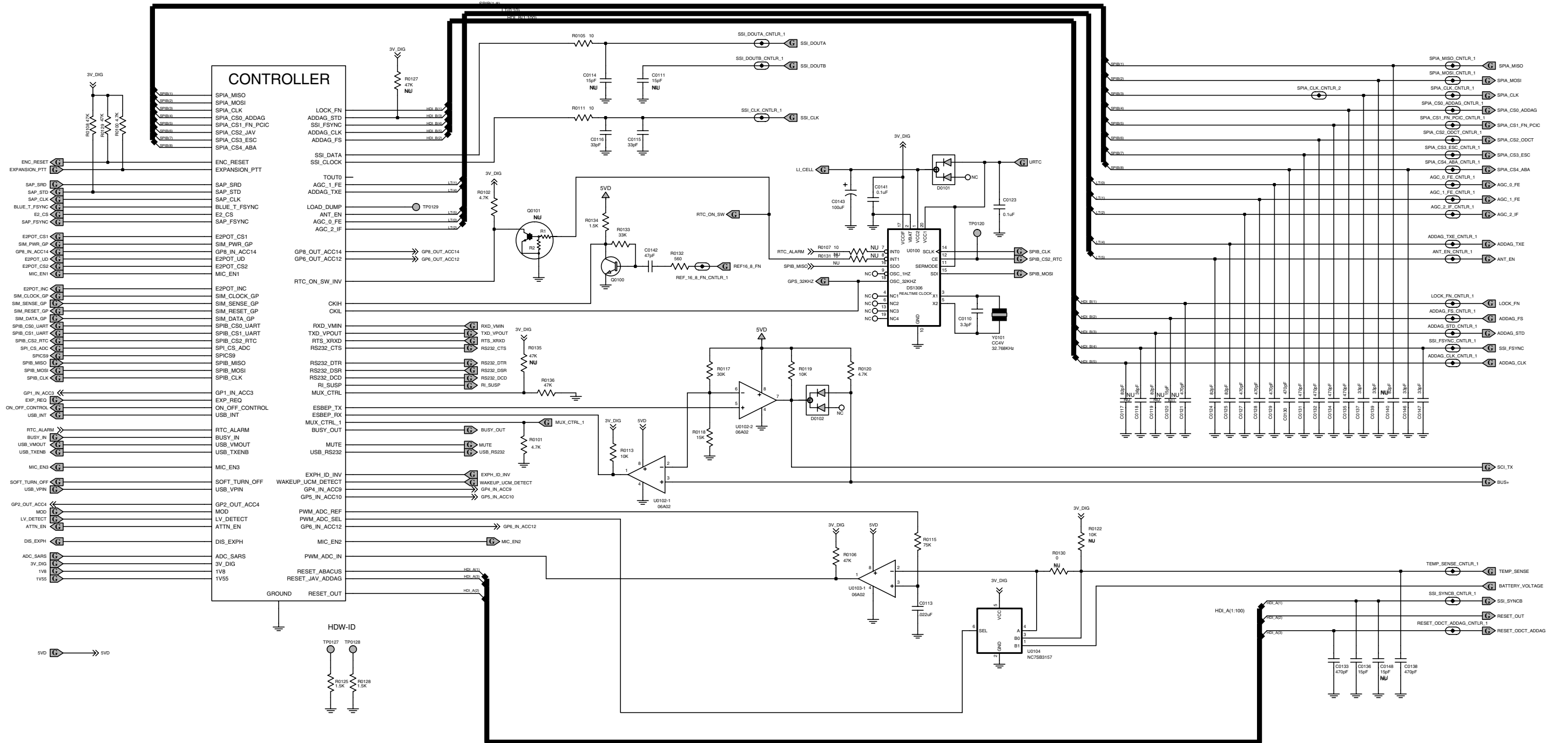

Main Board 8466582A02_B / Controller Section

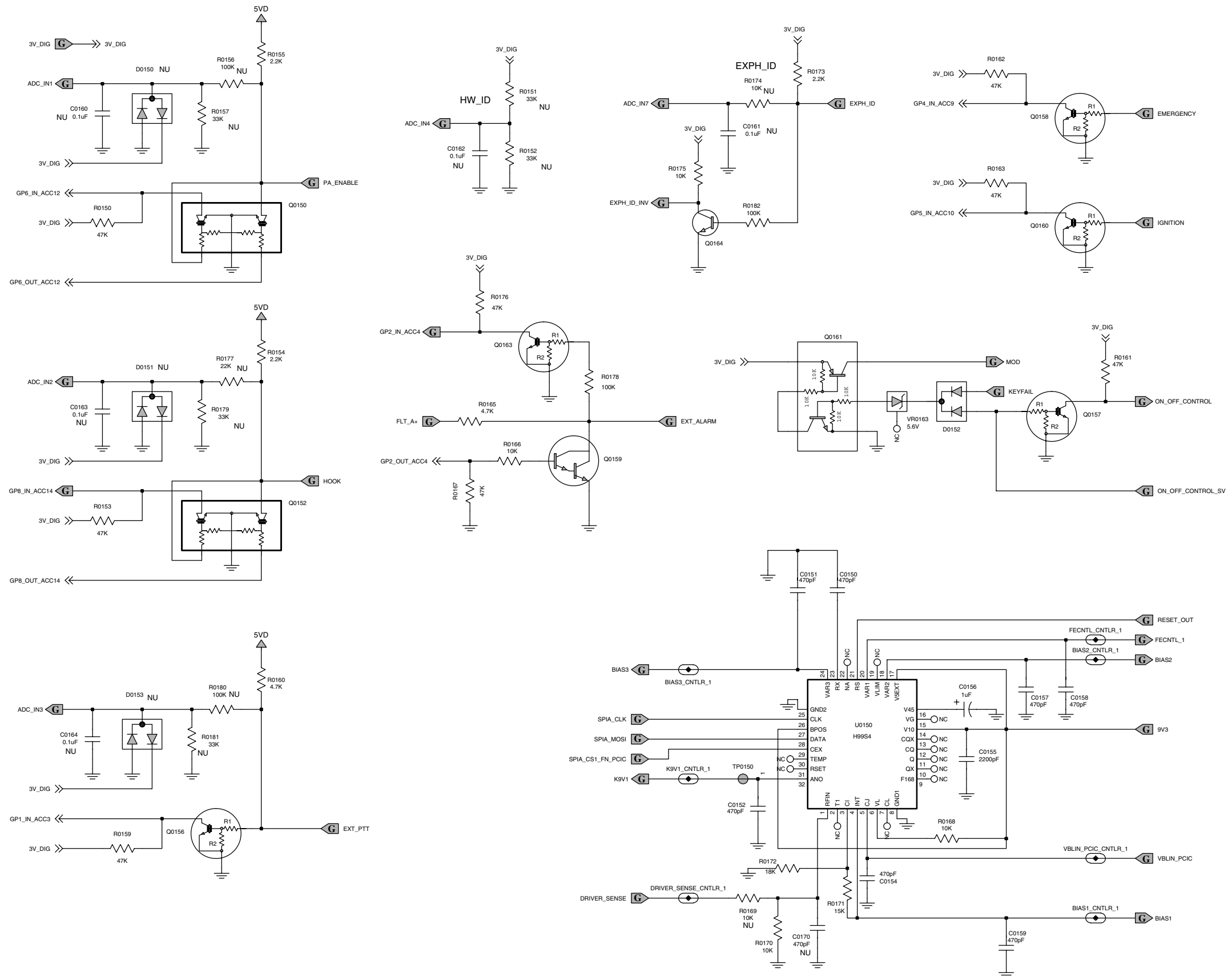

Main Board 8466582A02_B / Controller Port Section

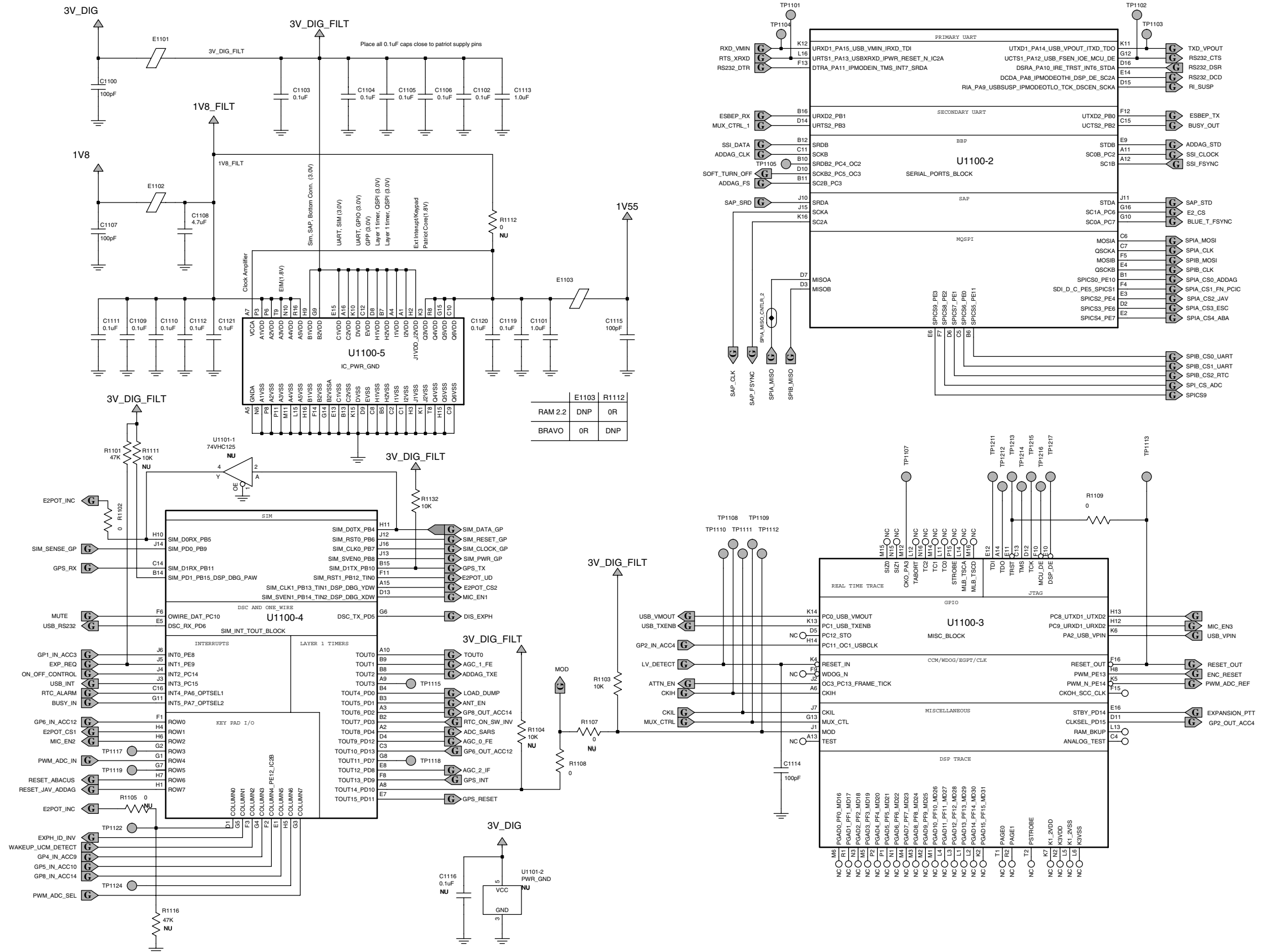

Main Board 8466582A02_B / Patriot Controller Section

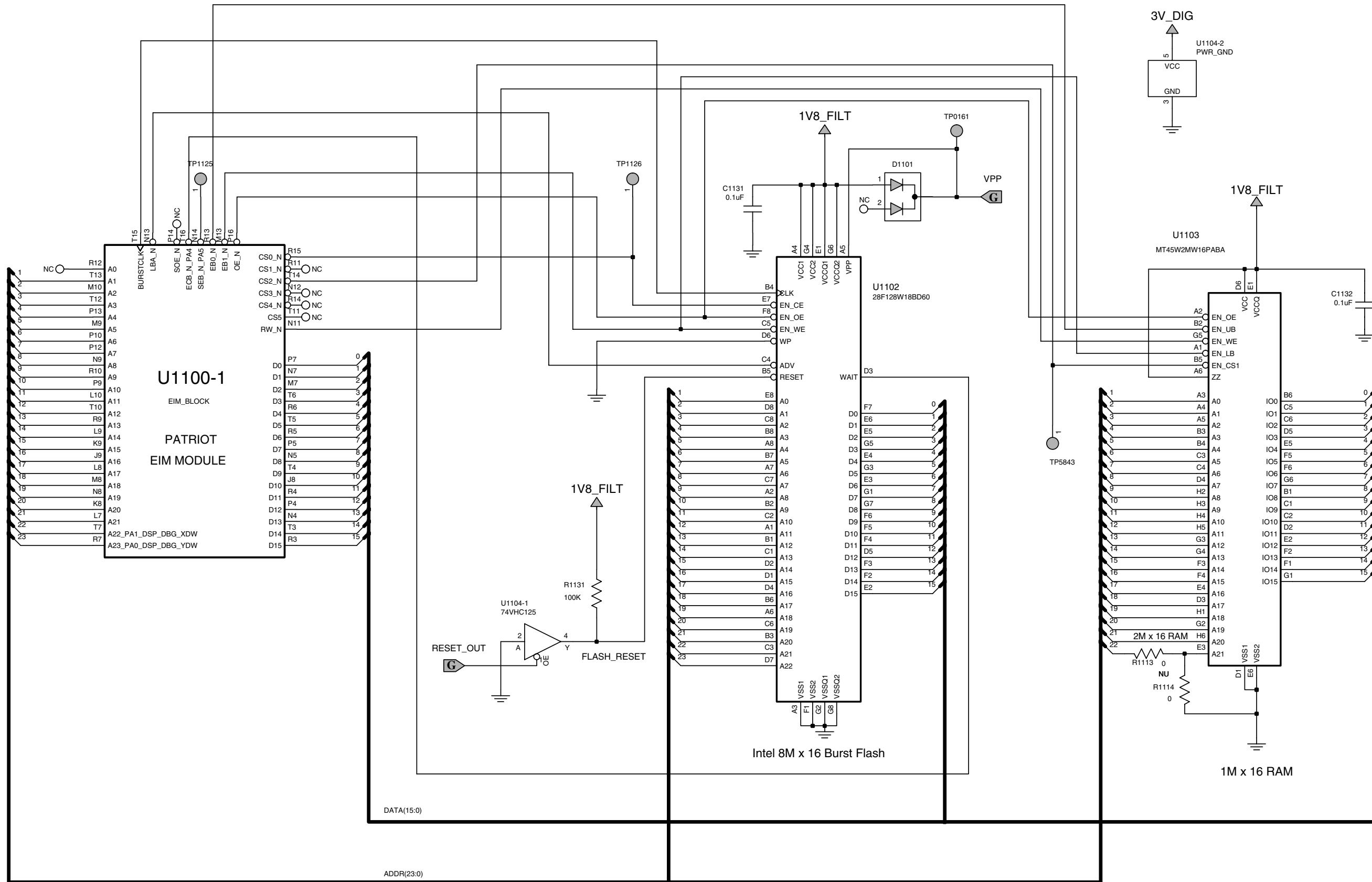

Main Board 8466582A02_B / Patriot Memory Section

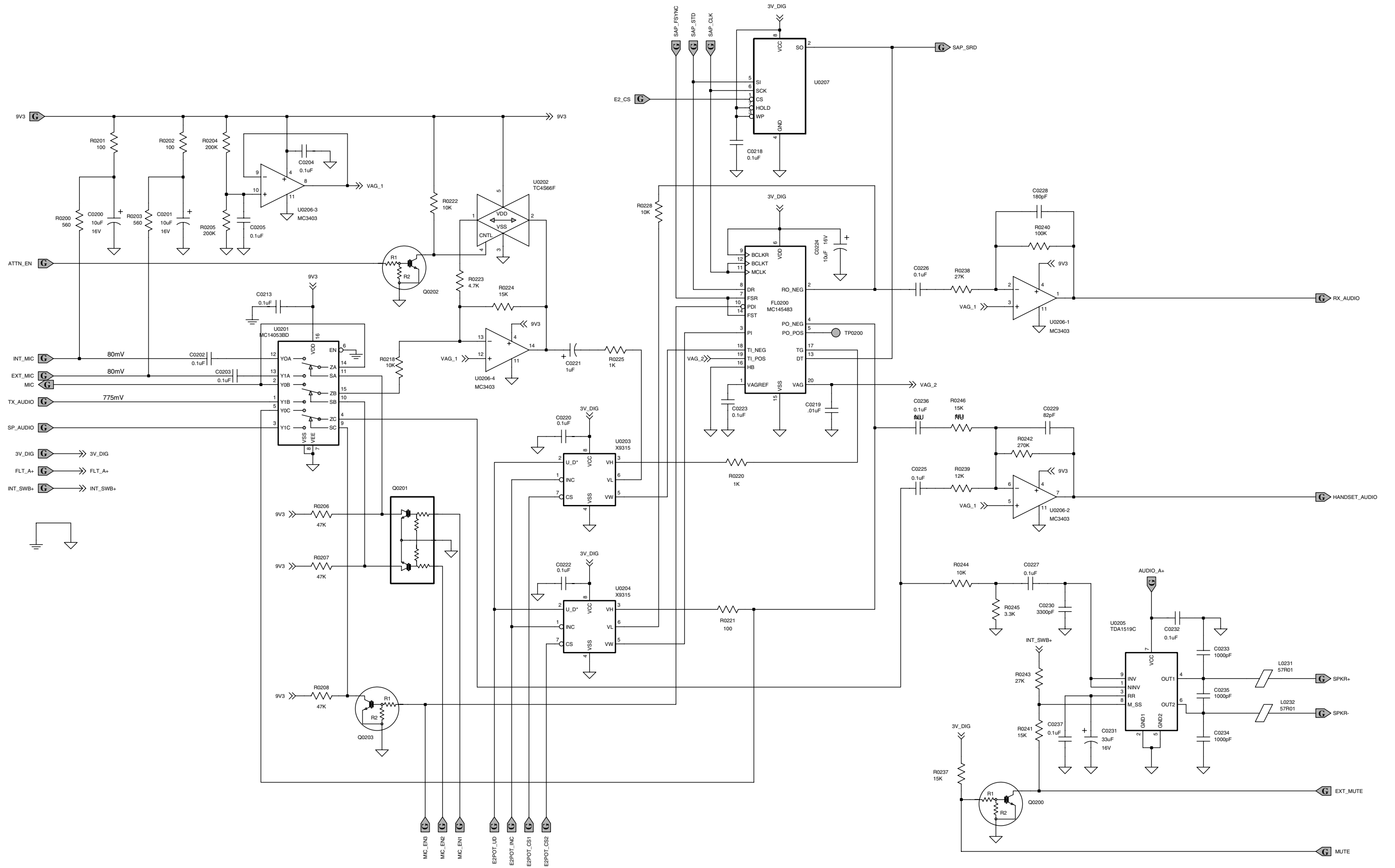

Main Board 8466582A02_B / Controller Audio Section

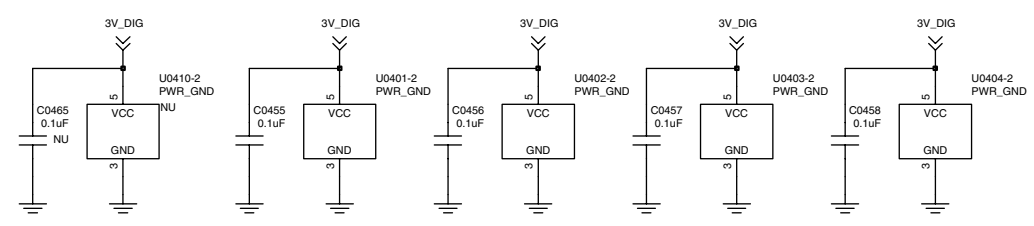
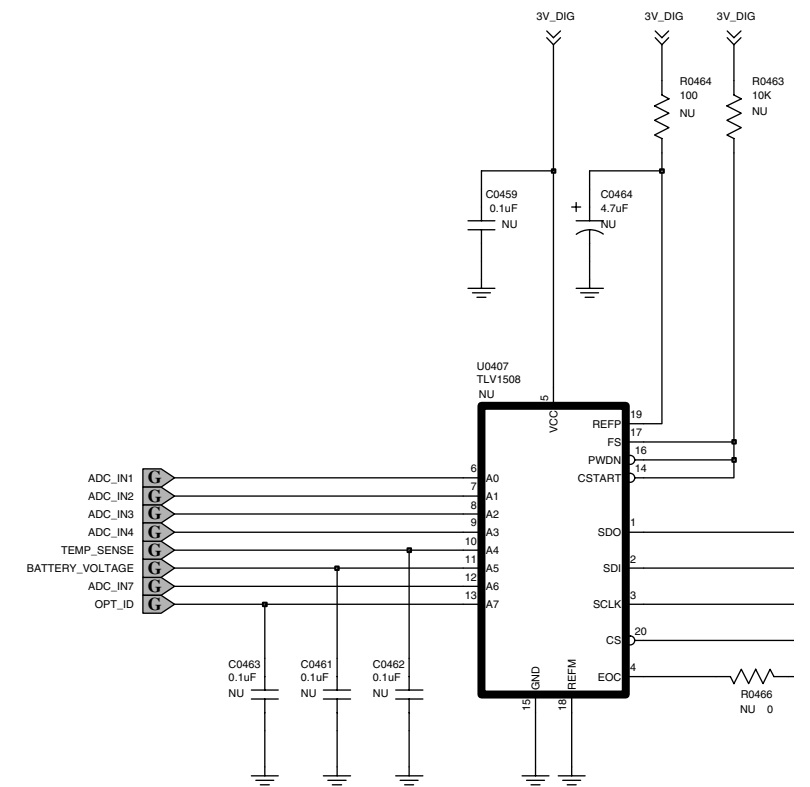
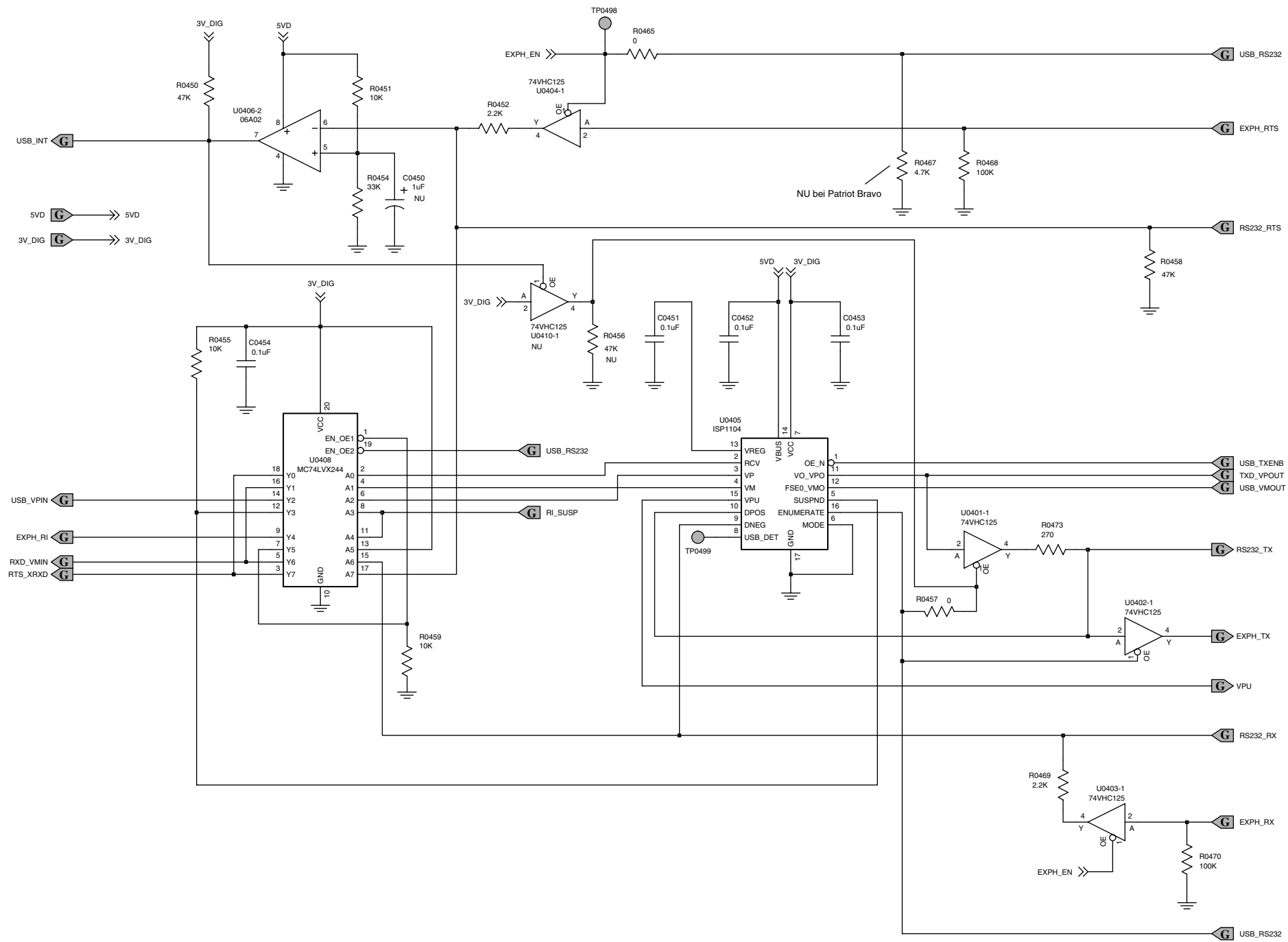

Main Board 8466582A02_B / Controller USB/ADC Section

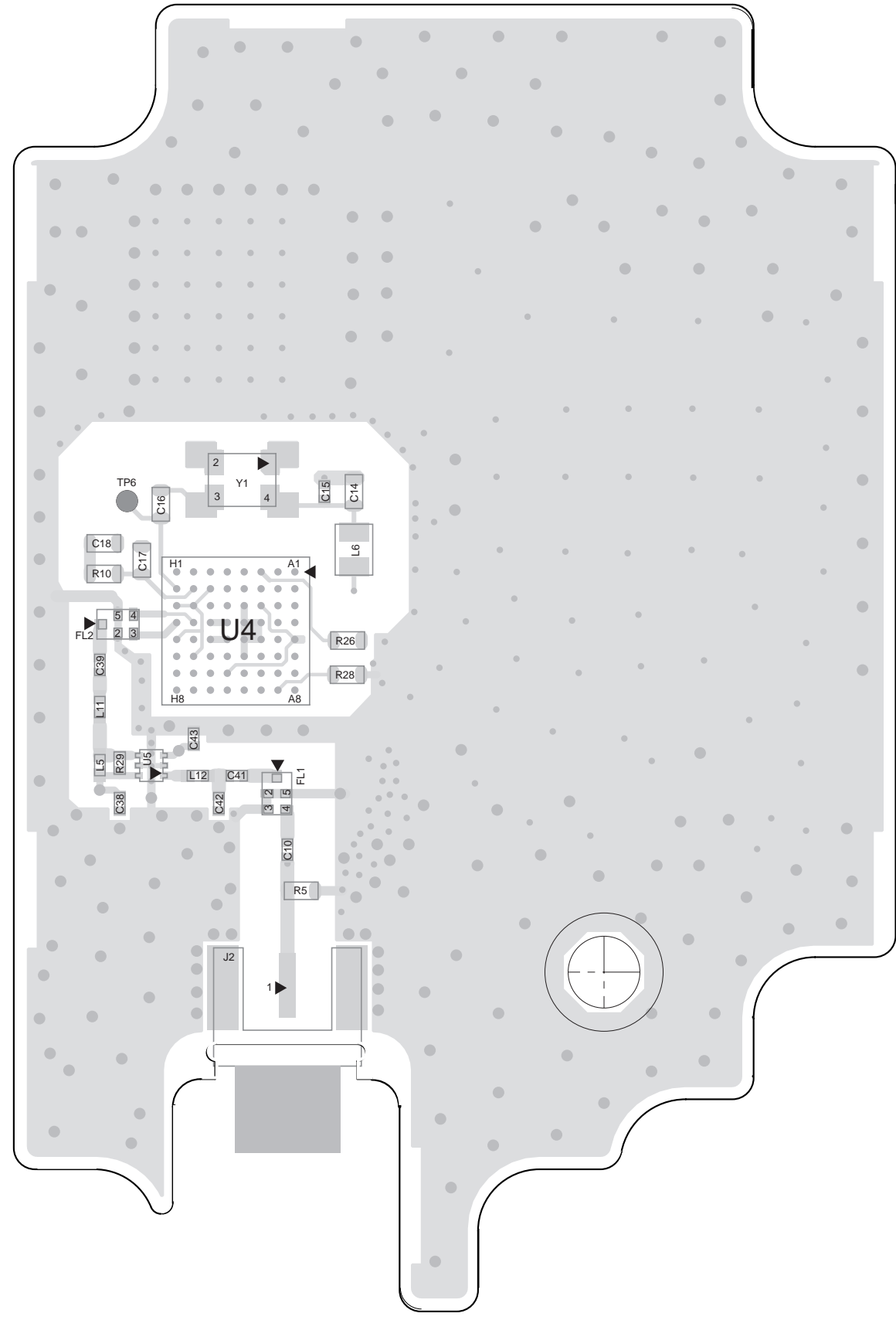
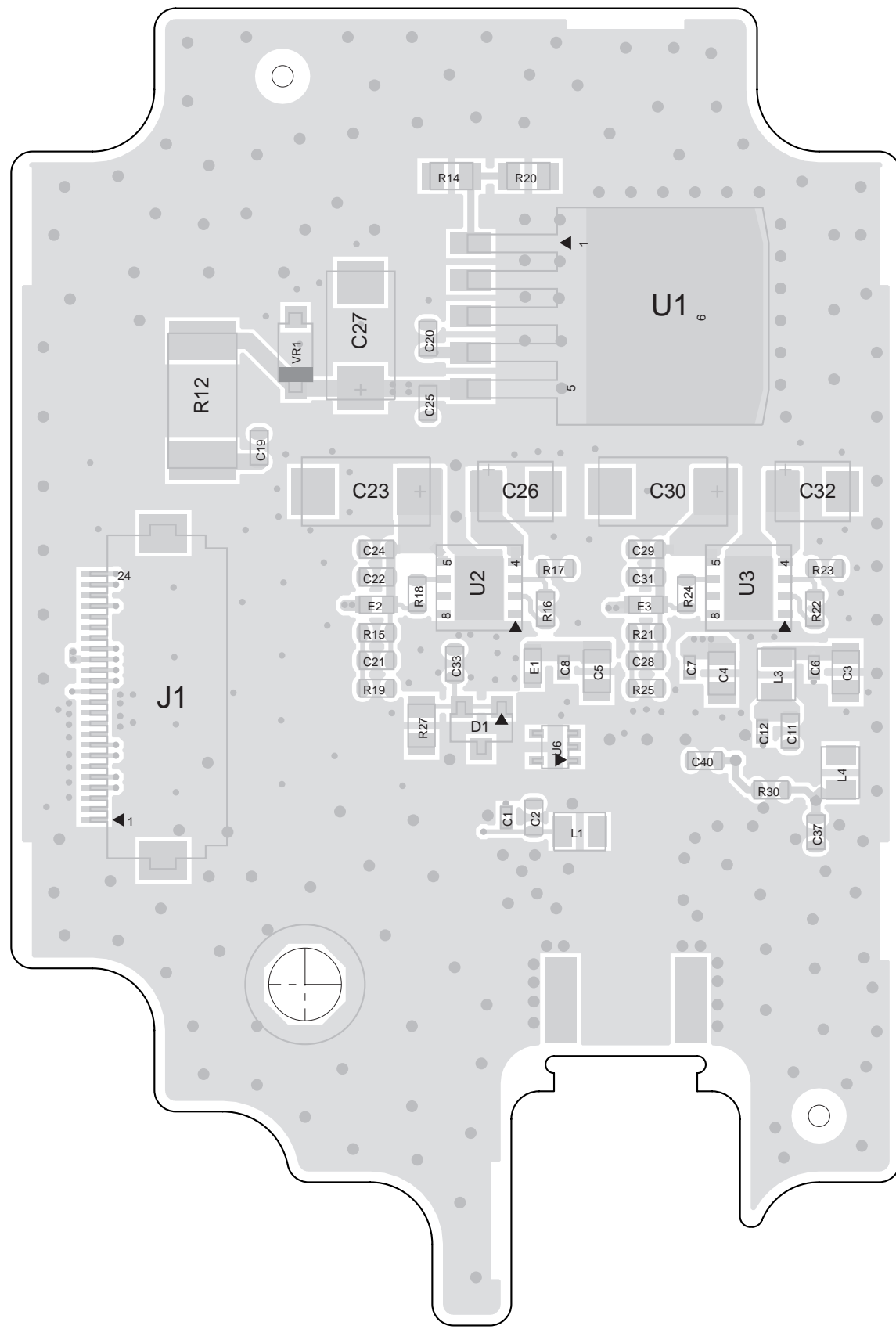

GPS Sub Module 8466576A01_O / PCB TOP & BOT side

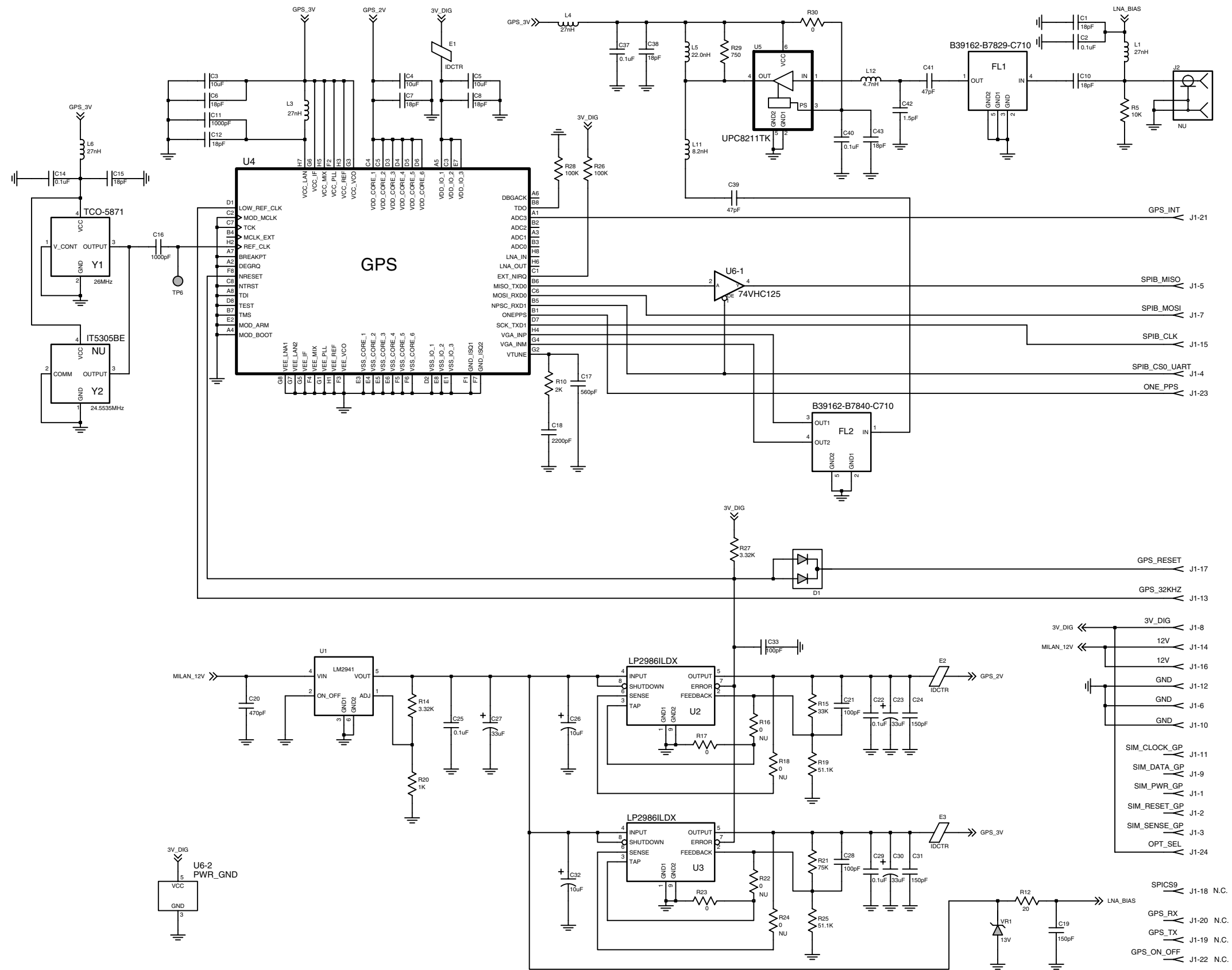

GPS Sub Module 8466576A01_O / Schematic

PARTS LISTS

Parts on the Mainboard (0166503N04)

Reference	Motorola PN	Value
C0110	2113944C18	CAP CER CHP 3.3PF 50V +/- 0.25
C0111	NOTPLACED	GCAM DUMMY PART NUMBER
C0113	2113945C04	CAP CER CHP 22,000PF 50V 10%
C0114	NOTPLACED	GCAM DUMMY PART NUMBER
C0115	2113944A31	CAP CER CHP 33.0PF 50V 5%
C0116	2113944A31	CAP CER CHP 33.0PF 50V 5%
C0117	NOTPLACED	GCAM DUMMY PART NUMBER
C0118	2113944C83	CAP,FXD,36PF,,+5%,-5%,50V-DC,0
C0119	NOTPLACED	GCAM DUMMY PART NUMBER
C0120	NOTPLACED	GCAM DUMMY PART NUMBER
C0121	2113944C06	CAP CER CHP 470.0PF 50V 5%
C0123	2113945D04	CAP CER CHP 100,000PF 25V 10%
C0124	2113944C43	CAP CER CHP 82.0PF 50V 5%
C0125	2113944C43	CAP CER CHP 82.0PF 50V 5%
C0127	2113944C06	CAP CER CHP 470.0PF 50V 5%
C0128	2113944C06	CAP CER CHP 470.0PF 50V 5%
C0129	2113944C06	CAP CER CHP 470.0PF 50V 5%
C0130	2113945A05	CAP CER CHP 470PF 50V 10%
C0131	2113944C06	CAP CER CHP 470.0PF 50V 5%
C0132	2113944C06	CAP CER CHP 470.0PF 50V 5%
C0133	2113944C06	CAP CER CHP 470.0PF 50V 5%
C0134	2113944C06	CAP CER CHP 470.0PF 50V 5%
C0135	2113944C06	CAP CER CHP 470.0PF 50V 5%
C0136	2113944A27	CAP CER CHP 15.0PF 50V 5%
C0137	2113944C36	CAP CER CHP 33.0PF 50V 5%
C0138	2113944C06	CAP CER CHP 470.0PF 50V 5%
C0139	2113944C36	CAP CER CHP 33.0PF 50V 5%
C0140	NOTPLACED	GCAM DUMMY PART NUMBER
C0141	2113945D04	CAP CER CHP 100,000PF 25V 10%
C0142	2113944C38	CAP CER CHP 47.0PF 50V 5%
C0143	2313960H07	CAP TANT 100 UF 10% 16V 7343-3
C0146	2113944A31	CAP CER CHP 33.0PF 50V 5%
C0147	2113944A31	CAP CER CHP 33.0PF 50V 5%
C0148	NOTPLACED	GCAM DUMMY PART NUMBER
C0150	2113944C06	CAP CER CHP 470.0PF 50V 5%
C0151	2113944C06	CAP CER CHP 470.0PF 50V 5%
C0152	2113944C06	CAP CER CHP 470.0PF 50V 5%
C0154	2113944C06	CAP CER CHP 470.0PF 50V 5%
C0155	2113945L33	CAP,FXD,2200PF,,+5%,-5%,50V-DC
C0156	2313960B01	CAP,FXD,1UF,+10%,-10%,16V-DC,S
C0157	2113944C06	CAP CER CHP 470.0PF 50V 5%
C0158	2113944C06	CAP CER CHP 470.0PF 50V 5%
C0159	2113944C06	CAP CER CHP 470.0PF 50V 5%
C0160	NOTPLACED	GCAM DUMMY PART NUMBER
C0161	NOTPLACED	GCAM DUMMY PART NUMBER

Reference	Motorola PN	Value
C0162	NOTPLACED	GCAM DUMMY PART NUMBER
C0163	NOTPLACED	GCAM DUMMY PART NUMBER
C0164	NOTPLACED	GCAM DUMMY PART NUMBER
C0170	NOTPLACED	GCAM DUMMY PART NUMBER
C0200	2313960D07	CAP,FXD,10,+10,-10,16,SM,,,-55M
C0201	2313960D07	CAP,FXD,10,+10,-10,16,SM,,,-55M
C0202	2113945D04	CAP CER CHP 100,000PF 25V 10%
C0203	2113945D04	CAP CER CHP 100,000PF 25V 10%
C0204	2113945D04	CAP CER CHP 100,000PF 25V 10%
C0205	2113945D04	CAP CER CHP 100,000PF 25V 10%
C0213	2113945D04	CAP CER CHP 100,000PF 25V 10%
C0218	2113945D04	CAP CER CHP 100,000PF 25V 10%
C0219	2113945C02	CAP CER CHP 10,000PF 50V 10%
C0220	2113945D04	CAP CER CHP 100,000PF 25V 10%
C0221	2313960B01	CAP,FXD,1UF,+10%,-10%,16V-DC,S
C0222	2113945D04	CAP CER CHP 100,000PF 25V 10%
C0223	2113945D04	CAP CER CHP 100,000PF 25V 10%
C0224	2313960D07	CAP,FXD,10,+10,-10,16,SM,,,-55M
C0225	2113945D04	CAP CER CHP 100,000PF 25V 10%
C0226	2113945D04	CAP CER CHP 100,000PF 25V 10%
C0227	2113945D04	CAP CER CHP 100,000PF 25V 10%
C0228	2113944C01	CAP CER CHP 180.0PF 50V 5%
C0229	2113944C43	CAP CER CHP 82.0PF 50V 5%
C0230	2113945L37	CAP,FXD,3300PF,+5%,-5%,50V-DC,
C0231	2313960F04	CAP TANT 33 UF 10% 16V 6032-28
C0232	2113945D04	CAP CER CHP 100,000PF 25V 10%
C0233	2113945L25	CAP,FXD,1000PF,+5%,-5%,50V-DC,
C0234	2113945L25	CAP,FXD,1000PF,+5%,-5%,50V-DC,
C0235	2113945L25	CAP,FXD,1000PF,+5%,-5%,50V-DC,
C0236	NOTPLACED	GCAM DUMMY PART NUMBER
C0237	2113945D04	CAP CER CHP 100,000PF 25V 10%
C0300	2113944C06	CAP CER CHP 470.0PF 50V 5%
C0301	2113944C06	CAP CER CHP 470.0PF 50V 5%
C0302	2313960F04	CAP TANT 33 UF 10% 16V 6032-28
C0303	2113945D04	CAP CER CHP 100,000PF 25V 10%
C0304	2113944C06	CAP CER CHP 470.0PF 50V 5%
C0305	NOTPLACED	GCAM DUMMY PART NUMBER
C0306	2389289U01	10UF 50V 20, ALUMINUM SMD
C0307	2113945C02	CAP CER CHP 10,000PF 50V 10%
C0308	2313960F04	CAP TANT 33 UF 10% 16V 6032-28
C0309	2313960F04	CAP TANT 33 UF 10% 16V 6032-28
C0310	2314030J28	CAP,FXD,22UF,+10%,-10%,35V-DC,
C0311	NOTPLACED	GCAM DUMMY PART NUMBER
C0312	2113945D04	CAP CER CHP 100,000PF 25V 10%
C0313	2113945D04	CAP CER CHP 100,000PF 25V 10%
C0314	NOTPLACED	GCAM DUMMY PART NUMBER
C0315	2313960F04	CAP TANT 33 UF 10% 16V 6032-28

Reference	Motorola PN	Value
C0316	2313960D07	CAP,FXD,10,+10,-10,16,SM,,,-55M
C0317	2113944C06	CAP CER CHP 470.0PF 50V 5%
C0318	NOTPLACED	GCAM DUMMY PART NUMBER
C0319	2113945D04	CAP CER CHP 100,000PF 25V 10%
C0320	NOTPLACED	GCAM DUMMY PART NUMBER
C0321	2113945D04	CAP CER CHP 100,000PF 25V 10%
C0322	2313960F30	CAP,FXD,47UF,+10%,-10%,10V-DC,
C0323	2313960D07	CAP,FXD,10,+10,-10,16,SM,,,-55M
C0324	2313960D07	CAP,FXD,10,+10,-10,16,SM,,,-55M
C0325	2313960C78	CAP,FXD,2.2UF,+10%,-10%,20V-DC
C0326	2113945C04	CAP CER CHP 22,000PF 50V 10%
C0328	2313960F30	CAP,FXD,47UF,+10%,-10%,10V-DC,
C0329	2311049A18	CAP. TANT 10% 10UF
C0330	NOTPLACED	GCAM DUMMY PART NUMBER
C0331	2313960F30	CAP,FXD,47UF,+10%,-10%,10V-DC,
C0332	NOTPLACED	GCAM DUMMY PART NUMBER
C0333	2113945D04	CAP CER CHP 100,000PF 25V 10%
C0334	2113945C02	CAP CER CHP 10,000PF 50V 10%
C0335	2113944C06	CAP CER CHP 470.0PF 50V 5%
C0336	2113944C06	CAP CER CHP 470.0PF 50V 5%
C0337	2113944C06	CAP CER CHP 470.0PF 50V 5%
C0338	2113944C06	CAP CER CHP 470.0PF 50V 5%
C0339	2113944C06	CAP CER CHP 470.0PF 50V 5%
C0340	NOTPLACED	GCAM DUMMY PART NUMBER
C0341	2113945D04	CAP CER CHP 100,000PF 25V 10%
C0342	NOTPLACED	GCAM DUMMY PART NUMBER
C0343	2113946F03	CAP CER CHP 4.7UF 6.3V 10%
C0344	2113945D04	CAP CER CHP 100,000PF 25V 10%
C0345	2113945C02	CAP CER CHP 10,000PF 50V 10%
C0346	NOTPLACED	GCAM DUMMY PART NUMBER
C0347	2113946F03	CAP CER CHP 4.7UF 6.3V 10%
C0348	2113946F03	CAP CER CHP 4.7UF 6.3V 10%
C0401	2113945D04	CAP CER CHP 100,000PF 25V 10%
C0402	2113945D04	CAP CER CHP 100,000PF 25V 10%
C0404	2113944C83	CAP,FXD,36PF,,+5%,-5%,50V-DC,0
C0405	2113944C83	CAP,FXD,36PF,,+5%,-5%,50V-DC,0
C0406	2113944C83	CAP,FXD,36PF,,+5%,-5%,50V-DC,0
C0407	2113944C83	CAP,FXD,36PF,,+5%,-5%,50V-DC,0
C0408	2113944C83	CAP,FXD,36PF,,+5%,-5%,50V-DC,0
C0409	2313960C78	CAP,FXD,2.2UF,+10%,-10%,20V-DC
C0410	2113944C83	CAP,FXD,36PF,,+5%,-5%,50V-DC,0
C0411	2113944C83	CAP,FXD,36PF,,+5%,-5%,50V-DC,0
C0412	2113944C83	CAP,FXD,36PF,,+5%,-5%,50V-DC,0
C0413	2113944C83	CAP,FXD,36PF,,+5%,-5%,50V-DC,0
C0414	2113944C83	CAP,FXD,36PF,,+5%,-5%,50V-DC,0
C0415	2113944C83	CAP,FXD,36PF,,+5%,-5%,50V-DC,0
C0416	2113944C83	CAP,FXD,36PF,,+5%,-5%,50V-DC,0

Reference	Motorola PN	Value
C0417	2113944C83	CAP,FXD,36PF,,+5%,-5%,50V-DC,0
C0418	2113944C36	CAP CER CHP 33.0PF 50V 5%
C0419	2113944C36	CAP CER CHP 33.0PF 50V 5%
C0420	2113944C83	CAP,FXD,36PF,,+5%,-5%,50V-DC,0
C0421	2113944C83	CAP,FXD,36PF,,+5%,-5%,50V-DC,0
C0450	NOTPLACED	GCAM DUMMY PART NUMBER
C0451	2113945D04	CAP CER CHP 100,000PF 25V 10%
C0452	2113945D04	CAP CER CHP 100,000PF 25V 10%
C0453	2113945D04	CAP CER CHP 100,000PF 25V 10%
C0454	2113945D04	CAP CER CHP 100,000PF 25V 10%
C0455	2113945D04	CAP CER CHP 100,000PF 25V 10%
C0456	2113945D04	CAP CER CHP 100,000PF 25V 10%
C0457	2113945D04	CAP CER CHP 100,000PF 25V 10%
C0458	2113945D04	CAP CER CHP 100,000PF 25V 10%
C0459	NOTPLACED	GCAM DUMMY PART NUMBER
C0460	2113946J03	CAP CER CHP 10.0UF 16V 10%
C0461	NOTPLACED	GCAM DUMMY PART NUMBER
C0462	NOTPLACED	GCAM DUMMY PART NUMBER
C0463	NOTPLACED	GCAM DUMMY PART NUMBER
C0464	NOTPLACED	GCAM DUMMY PART NUMBER
C0465	NOTPLACED	GCAM DUMMY PART NUMBER
C0502	2113944A36	CAP CER CHP 68.0PF 50V 5%
C0503	2113944A36	CAP CER CHP 68.0PF 50V 5%
C0504	2113944A36	CAP CER CHP 68.0PF 50V 5%
C0505	2113944A36	CAP CER CHP 68.0PF 50V 5%
C0506	2113944A36	CAP CER CHP 68.0PF 50V 5%
C0507	2113944A36	CAP CER CHP 68.0PF 50V 5%
C0508	2113944A36	CAP CER CHP 68.0PF 50V 5%
C0509	2113944A36	CAP CER CHP 68.0PF 50V 5%
C0510	2113944A36	CAP CER CHP 68.0PF 50V 5%
C0511	2113944A36	CAP CER CHP 68.0PF 50V 5%
C0512	2113944A36	CAP CER CHP 68.0PF 50V 5%
C0513	2113944A36	CAP CER CHP 68.0PF 50V 5%
C0515	2113944A36	CAP CER CHP 68.0PF 50V 5%
C0517	2113944A36	CAP CER CHP 68.0PF 50V 5%
C0519	2113944A36	CAP CER CHP 68.0PF 50V 5%
C0520	2113944A36	CAP CER CHP 68.0PF 50V 5%
C0521	2113944A36	CAP CER CHP 68.0PF 50V 5%
C0522	2113944A36	CAP CER CHP 68.0PF 50V 5%
C0523	2113944A36	CAP CER CHP 68.0PF 50V 5%
C0524	2113944A36	CAP CER CHP 68.0PF 50V 5%
C0525	2113944A36	CAP CER CHP 68.0PF 50V 5%
C0526	2113944A36	CAP CER CHP 68.0PF 50V 5%
C0527	2113944A36	CAP CER CHP 68.0PF 50V 5%
C0528	2113944A36	CAP CER CHP 68.0PF 50V 5%
C0529	2113944A36	CAP CER CHP 68.0PF 50V 5%
C0530	2113944A36	CAP CER CHP 68.0PF 50V 5%

Reference	Motorola PN	Value
C0531	2113944A36	CAP CER CHP 68.0PF 50V 5%
C0532	2113944A36	CAP CER CHP 68.0PF 50V 5%
C0533	2113944A36	CAP CER CHP 68.0PF 50V 5%
C0534	2113944A36	CAP CER CHP 68.0PF 50V 5%
C0535	2113944A36	CAP CER CHP 68.0PF 50V 5%
C0536	2113944A36	CAP CER CHP 68.0PF 50V 5%
C0537	2113944A36	CAP CER CHP 68.0PF 50V 5%
C0538	2113944A36	CAP CER CHP 68.0PF 50V 5%
C0539	NOTPLACED	GCAM DUMMY PART NUMBER
C0540	2113944A36	CAP CER CHP 68.0PF 50V 5%
C0550	2113944A31	CAP CER CHP 33.0PF 50V 5%
C0551	2113944C83	CAP,FXD,36PF,,+5%,-5%,50V-DC,0
C0552	2113944C83	CAP,FXD,36PF,,+5%,-5%,50V-DC,0
C0553	2113944C83	CAP,FXD,36PF,,+5%,-5%,50V-DC,0
C0554	2113944A31	CAP CER CHP 33.0PF 50V 5%
C0555	2113944C83	CAP,FXD,36PF,,+5%,-5%,50V-DC,0
C0556	2113944C83	CAP,FXD,36PF,,+5%,-5%,50V-DC,0
C0557	2113944C83	CAP,FXD,36PF,,+5%,-5%,50V-DC,0
C0558	2113944C83	CAP,FXD,36PF,,+5%,-5%,50V-DC,0
C0559	2113944C83	CAP,FXD,36PF,,+5%,-5%,50V-DC,0
C0560	2113944C83	CAP,FXD,36PF,,+5%,-5%,50V-DC,0
C0561	2113944C83	CAP,FXD,36PF,,+5%,-5%,50V-DC,0
C0601	2113944A31	CAP CER CHP 33.0PF 50V 5%
C0603	2113944A31	CAP CER CHP 33.0PF 50V 5%
C0604	2113944A31	CAP CER CHP 33.0PF 50V 5%
C0605	2113944A31	CAP CER CHP 33.0PF 50V 5%
C0606	2113944A31	CAP CER CHP 33.0PF 50V 5%
C0607	2113944A31	CAP CER CHP 33.0PF 50V 5%
C0608	2113944B01	CAP CER CHP 180.0PF 25V 5%
C0609	2113944A31	CAP CER CHP 33.0PF 50V 5%
C0610	2113944A31	CAP CER CHP 33.0PF 50V 5%
C0611	2113944A31	CAP CER CHP 33.0PF 50V 5%
C0612	2113944A31	CAP CER CHP 33.0PF 50V 5%
C0613	2113944A31	CAP CER CHP 33.0PF 50V 5%
C0614	2113944A31	CAP CER CHP 33.0PF 50V 5%
C0615	2113944A31	CAP CER CHP 33.0PF 50V 5%
C0616	2113944A31	CAP CER CHP 33.0PF 50V 5%
C0617	2113944A31	CAP CER CHP 33.0PF 50V 5%
C0618	2113944A31	CAP CER CHP 33.0PF 50V 5%
C0619	2113944A31	CAP CER CHP 33.0PF 50V 5%
C1100	2113944C45	CAP CER CHP 100.0PF 50V 5%
C1101	2113946M01	CAP CER CHP 1.0UF 10V
C1102	2113945D04	CAP CER CHP 100,000PF 25V 10%
C1103	2113945D04	CAP CER CHP 100,000PF 25V 10%
C1104	2113945D04	CAP CER CHP 100,000PF 25V 10%
C1105	2113945D04	CAP CER CHP 100,000PF 25V 10%
C1106	2113945D04	CAP CER CHP 100,000PF 25V 10%

Reference	Motorola PN	Value
C1107	2113944C45	CAP CER CHP 100.0PF 50V 5%
C1108	2113946F03	CAP CER CHP 4.7UF 6.3V 10%
C1109	2113945D04	CAP CER CHP 100,000PF 25V 10%
C1110	2113945D04	CAP CER CHP 100,000PF 25V 10%
C1111	2113945D04	CAP CER CHP 100,000PF 25V 10%
C1112	2113945D04	CAP CER CHP 100,000PF 25V 10%
C1113	2113946M01	CAP CER CHP 1.0UF 10V
C1114	2113944C45	CAP CER CHP 100.0PF 50V 5%
C1115	2113944C45	CAP CER CHP 100.0PF 50V 5%
C1116	NOTPLACED	GCAM DUMMY PART NUMBER
C1119	2113945D04	CAP CER CHP 100,000PF 25V 10%
C1120	2113945D04	CAP CER CHP 100,000PF 25V 10%
C1121	2113945D04	CAP CER CHP 100,000PF 25V 10%
C1131	2113945D04	CAP CER CHP 100,000PF 25V 10%
C1132	2113945D04	CAP CER CHP 100,000PF 25V 10%
C1133	NOTPLACED	GCAM DUMMY PART NUMBER
C5001	2113945B02	CAP CER CHP 10,000PF 25V 10%
C5002	2113945B02	CAP CER CHP 10,000PF 25V 10%
C5003	2313960B01	CAP,FXD,1UF,+10%,-10%,16V-DC,S
C5004	2113946K02	CAP CER CHP 0.10UF 16V
C5005	2313960B30	CAP,FXD,4.7UF,+10%,-10%,10V-DC
C5007	2113945B02	CAP CER CHP 10,000PF 25V 10%
C5008	2313960B30	CAP,FXD,4.7UF,+10%,-10%,10V-DC
C5009	2113944A36	CAP CER CHP 68.0PF 50V 5%
C5010	2113945B02	CAP CER CHP 10,000PF 25V 10%
C5011	2113944A36	CAP CER CHP 68.0PF 50V 5%
C5012	2113946B04	CAP CER CHP 0.10UF 10V 10%
C5013	2113944A06	CAP CER CHP 1.6PF 50V +/- 0.25
C5015	2113946K02	CAP CER CHP 0.10UF 16V
C5016	2113945A09	CAP CER CHP 1000PF 50V 10%
C5017	2113944A36	CAP CER CHP 68.0PF 50V 5%
C5018	2113944A36	CAP CER CHP 68.0PF 50V 5%
C5019	2113944A08	CAP CER CHP 2.0PF 50V +/- 0.25
C5020	2113944A06	CAP CER CHP 1.6PF 50V +/- 0.25
C5021	2113944A27	CAP CER CHP 15.0PF 50V 5%
C5022	2113944A28	CAP CER CHP 18.0PF 50V 5%
C5023	2113944A33	CAP CER CHP 47.0PF 50V 5%
C5024	2113946B04	CAP CER CHP 0.10UF 10V 10%
C5025	2113944A23	CAP CER CHP 8.2PF 50V +/- 0.5P
C5026	2113944A06	CAP CER CHP 1.6PF 50V +/- 0.25
C5027	2113944A16	CAP CER CHP 4.3PF 50V +/- 0.25
C5028	2113944A36	CAP CER CHP 68.0PF 50V 5%
C5029	2113946B04	CAP CER CHP 0.10UF 10V 10%
C5030	2113945A03	CAP CER CHP 330PF 50V 10%
C5031	2313960B01	CAP,FXD,1UF,+10%,-10%,16V-DC,S
C5032	2113945B02	CAP CER CHP 10,000PF 25V 10%
C5033	2113944A36	CAP CER CHP 68.0PF 50V 5%

Reference	Motorola PN	Value
C5034	2113945A09	CAP CER CHP 1000PF 50V 10%
C5035	2113945A09	CAP CER CHP 1000PF 50V 10%
C5036	2113944A28	CAP CER CHP 18.0PF 50V 5%
C5037	2113945A03	CAP CER CHP 330PF 50V 10%
C5038	2113944A06	CAP CER CHP 1.6PF 50V +/- 0.25
C5039	2113944A18	CAP CER CHP 5.1PF 50V +/- 0.5P
C5040	2113944A14	CAP CER CHP 3.6PF 50V +/- 0.25
C5041	2113944A31	CAP CER CHP 33.0PF 50V 5%
C5042	2113944A36	CAP CER CHP 68.0PF 50V 5%
C5043	2113944A36	CAP CER CHP 68.0PF 50V 5%
C5044	2113944A36	CAP CER CHP 68.0PF 50V 5%
C5045	2113944A36	CAP CER CHP 68.0PF 50V 5%
C5046	2113944A18	CAP CER CHP 5.1PF 50V +/- 0.5P
C5101	2113944C04	CAP CER CHP 330.0PF 50V 5%
C5102	NOTPLACED	GCAM DUMMY PART NUMBER
C5103	2113945L49	CAP,FXD,.01UF,,+5%,-5%,50V-DC,
C5104	2113945C31	CAP,FXD,.1UF,+10%,-10%,50V-DC,
C5111	2113945C31	CAP,FXD,.1UF,+10%,-10%,50V-DC,
C5112	NOTPLACED	GCAM DUMMY PART NUMBER
C5113	NOTPLACED	GCAM DUMMY PART NUMBER
C5120	NOTPLACED	GCAM DUMMY PART NUMBER
C5121	NOTPLACED	GCAM DUMMY PART NUMBER
C5122	2113945L25	CAP,FXD,1000PF,+5%,-5%,50V-DC,
C5123	NOTPLACED	GCAM DUMMY PART NUMBER
C5124	2113945L49	CAP,FXD,.01UF,,+5%,-5%,50V-DC,
C5125	2113944C75	CAP,FXD,8.2PF,.25PF+/-,50V-DC,
C5126	2113944C32	CAP CER CHP 15.0PF 50V 5%
C5127	2113944C04	CAP CER CHP 330.0PF 50V 5%
C5128	2113945C31	CAP,FXD,.1UF,+10%,-10%,50V-DC,
C5129	2113945L49	CAP,FXD,.01UF,,+5%,-5%,50V-DC,
C5130	2113945C31	CAP,FXD,.1UF,+10%,-10%,50V-DC,
C5131	2113945L49	CAP,FXD,.01UF,,+5%,-5%,50V-DC,
C5132	2113945C31	CAP,FXD,.1UF,+10%,-10%,50V-DC,
C5133	2113945C31	CAP,FXD,.1UF,+10%,-10%,50V-DC,
C5134	2113945C31	CAP,FXD,.1UF,+10%,-10%,50V-DC,
C5135	2113945C31	CAP,FXD,.1UF,+10%,-10%,50V-DC,
C5136	2113945C31	CAP,FXD,.1UF,+10%,-10%,50V-DC,
C5137	2113945L49	CAP,FXD,.01UF,,+5%,-5%,50V-DC,
C5138	2113945C31	CAP,FXD,.1UF,+10%,-10%,50V-DC,
C5139	2113945C31	CAP,FXD,.1UF,+10%,-10%,50V-DC,
C5140	2113945D04	CAP CER CHP 100,000PF 25V 10%
C5141	2113945D04	CAP CER CHP 100,000PF 25V 10%
C5142	2113944C45	CAP CER CHP 100.0PF 50V 5%
C5144	2113944C45	CAP CER CHP 100.0PF 50V 5%
C5145	NOTPLACED	GCAM DUMMY PART NUMBER
C5146	2113944C45	CAP CER CHP 100.0PF 50V 5%
C5147	2113945C31	CAP,FXD,.1UF,+10%,-10%,50V-DC,

Reference	Motorola PN	Value
C5148	NOTPLACED	GCAM DUMMY PART NUMBER
C5150	2113945L49	CAP,FXD,.01UF,,+5%,-5%,50V-DC,
C5151	2113945L49	CAP,FXD,.01UF,,+5%,-5%,50V-DC,
C5152	2113945C31	CAP,FXD,.1UF,+10%,-10%,50V-DC,
C5153	2113945C31	CAP,FXD,.1UF,+10%,-10%,50V-DC,
C5154	2113945C31	CAP,FXD,.1UF,+10%,-10%,50V-DC,
C5155	2113945C31	CAP,FXD,.1UF,+10%,-10%,50V-DC,
C5156	2113945L49	CAP,FXD,.01UF,,+5%,-5%,50V-DC,
C5157	2113945L49	CAP,FXD,.01UF,,+5%,-5%,50V-DC,
C5158	2113945L25	CAP,FXD,1000PF,+5%,-5%,50V-DC,
C5159	2113945L49	CAP,FXD,.01UF,,+5%,-5%,50V-DC,
C5160	2113945L25	CAP,FXD,1000PF,+5%,-5%,50V-DC,
C5161	2113944C36	CAP CER CHP 33.0PF 50V 5%
C5162	2113944C36	CAP CER CHP 33.0PF 50V 5%
C5163	2113944C36	CAP CER CHP 33.0PF 50V 5%
C5164	2113944C36	CAP CER CHP 33.0PF 50V 5%
C5166	2313960B01	CAP,FXD,1UF,+10%,-10%,16V-DC,S
C5167	2313960B30	CAP,FXD,4.7UF,+10%,-10%,10V-DC
C5168	2313960B30	CAP,FXD,4.7UF,+10%,-10%,10V-DC
C5169	2313960B01	CAP,FXD,1UF,+10%,-10%,16V-DC,S
C5171	2113944C32	CAP CER CHP 15.0PF 50V 5%
C5172	2113945C31	CAP,FXD,.1UF,+10%,-10%,50V-DC,
C5173	2113944C32	CAP CER CHP 15.0PF 50V 5%
C5174	2113944C32	CAP CER CHP 15.0PF 50V 5%
C5175	2113944C32	CAP CER CHP 15.0PF 50V 5%
C5176	2113944C01	CAP CER CHP 180.0PF 50V 5%
C5177	2113944C32	CAP CER CHP 15.0PF 50V 5%
C5178	2113944C45	CAP CER CHP 100.0PF 50V 5%
C5179	2113944C45	CAP CER CHP 100.0PF 50V 5%
C5180	2113944C41	CAP CER CHP 68.0PF 50V 5%
C5181	2113944C32	CAP CER CHP 15.0PF 50V 5%
C5182	2113944C34	CAP CER CHP 22.0PF 50V 5%
C5183	2113944C34	CAP CER CHP 22.0PF 50V 5%
C5184	2113945L49	CAP,FXD,.01UF,,+5%,-5%,50V-DC,
C5185	2113945C31	CAP,FXD,.1UF,+10%,-10%,50V-DC,
C5186	2113945L25	CAP,FXD,1000PF,+5%,-5%,50V-DC,
C5187	2113944C30	CAP CER CHP 10.0PF 50V +/- 0.5
C5188	2113945G95	CAP,FXD,.22UF,+10%,-10%,50V-DC
C5189	2313960C78	CAP,FXD,2.2UF,+10%,-10%,20V-DC
C5190	2113944C45	CAP CER CHP 100.0PF 50V 5%
C5191	2113944C45	CAP CER CHP 100.0PF 50V 5%
C5192	2113944C47	CAP CER CHP 150.0PF 50V 5%
C5193	2113944C45	CAP CER CHP 100.0PF 50V 5%
C5194	2113945L49	CAP,FXD,.01UF,,+5%,-5%,50V-DC,
C5195	2113945C31	CAP,FXD,.1UF,+10%,-10%,50V-DC,
C5197	2113944C32	CAP CER CHP 15.0PF 50V 5%
C5198	2113945G95	CAP,FXD,.22UF,+10%,-10%,50V-DC

Reference	Motorola PN	Value
C5199	2313960C78	CAP,FXD,2.2UF,+10%,-10%,20V-DC
C5202	2113944C73	CAP,FXD,6.8PF,.25PF+/-,,50V-D
C5203	2113944C77	CAP,FXD,11PF,+5%,-5%,50V-DC,0
C5204	2113944C31	CAP CER CHP 12.0PF 50V 5%
C5205	2113944C32	CAP CER CHP 15.0PF 50V 5%
C5206	2113944C35	CAP CER CHP 27.0PF 50V 5%
C5208	2113945C31	CAP,FXD,.1UF,+10%,-10%,50V-DC,
C5209	2113945C31	CAP,FXD,.1UF,+10%,-10%,50V-DC,
C5210	2113944C04	CAP CER CHP 330.0PF 50V 5%
C5211	2113944C04	CAP CER CHP 330.0PF 50V 5%
C5212	NOTPLACED	GCAM DUMMY PART NUMBER
C5213	NOTPLACED	GCAM DUMMY PART NUMBER
C5214	NOTPLACED	GCAM DUMMY PART NUMBER
C5215	NOTPLACED	GCAM DUMMY PART NUMBER
C5216	NOTPLACED	GCAM DUMMY PART NUMBER
C5219	NOTPLACED	GCAM DUMMY PART NUMBER
C5220	2113944M16	CAP,FXD,8.2PF,.1PF+/-,50V-DC,0
C5221	2113944M22	CAP,FXD,15PF,+2%,-2%,50V-DC,06
C5301	2113945L43	CAP,FXD,5600PF,+5%,-5%,50V-DC,
C5303	0804533C33	CAP METAL/POLY FILM 0.047
C5305	2113945L43	CAP,FXD,5600PF,+5%,-5%,50V-DC,
C5306	2113946K02	CAP CER CHP 0.10UF 16V
C5307	2313960D07	CAP,FXD,10,+10,-10,16,SM,,,-55M
C5308	2113944A36	CAP CER CHP 68.0PF 50V 5%
C5311	2113945B02	CAP CER CHP 10,000PF 25V 10%
C5312	2113945B02	CAP CER CHP 10,000PF 25V 10%
C5313	2113945B02	CAP CER CHP 10,000PF 25V 10%
C5314	2113945B02	CAP CER CHP 10,000PF 25V 10%
C5315	2113945B02	CAP CER CHP 10,000PF 25V 10%
C5316	2313960D07	CAP,FXD,10,+10,-10,16,SM,,,-55M
C5317	2113944A29	CAP CER CHP 22.0PF 50V 5%
C5318	2313960B28	CAP TANT 2.2 UF 10% 10V 3216-1
C5319	2113946K02	CAP CER CHP 0.10UF 16V
C5321	2313960B30	CAP,FXD,4.7UF,+10%,-10%,10V-DC
C5322	2113946K02	CAP CER CHP 0.10UF 16V
C5323	2113944A36	CAP CER CHP 68.0PF 50V 5%
C5324	2313960D07	CAP,FXD,10,+10,-10,16,SM,,,-55M
C5331	NOTPLACED	GCAM DUMMY PART NUMBER
C5332	NOTPLACED	GCAM DUMMY PART NUMBER
C5333	2113944A36	CAP CER CHP 68.0PF 50V 5%
C5334	2113946K02	CAP CER CHP 0.10UF 16V
C5335	NOTPLACED	GCAM DUMMY PART NUMBER
C5336	2113945C03	CAP CER CHP 15,000PF 50V 10%
C5337	NOTPLACED	GCAM DUMMY PART NUMBER
C5338	2113944A36	CAP CER CHP 68.0PF 50V 5%
C5339	2313960B30	CAP,FXD,4.7UF,+10%,-10%,10V-DC
C5340	2113944A31	CAP CER CHP 33.0PF 50V 5%

Reference	Motorola PN	Value
C5341	2113944A31	CAP CER CHP 33.0PF 50V 5%
C5342	2113944A31	CAP CER CHP 33.0PF 50V 5%
C5343	2313960D07	CAP,FXD,10,+10,-10,16,SM,,,-55M
C5344	2113945A09	CAP CER CHP 1000PF 50V 10%
C5345	2113944A36	CAP CER CHP 68.0PF 50V 5%
C5346	2113945L17	CAP,FXD,470PF,+5%,-5%,50V-DC,0
C5347	2113944A25	CAP CER CHP 10.0PF 50V +/- 0.5
C5351	2113946K02	CAP CER CHP 0.10UF 16V
C5352	2113945A09	CAP CER CHP 1000PF 50V 10%
C5353	2113946K02	CAP CER CHP 0.10UF 16V
C5361	2113944A34	CAP CER CHP 56.0PF 50V 5%
C5362	2113946K02	CAP CER CHP 0.10UF 16V
C5363	2113946K02	CAP CER CHP 0.10UF 16V
C5365	2113944A33	CAP CER CHP 47.0PF 50V 5%
C5366	2113946K02	CAP CER CHP 0.10UF 16V
C5367	2113945C31	CAP,FXD,.1UF,+10%,-10%,50V-DC,
C5400	2113944M21	CAP,FXD,13PF,+2%,-2%,50V-DC,0
C5401	2113944A34	CAP CER CHP 56.0PF 50V 5%
C5402	NOTPLACED	GCAM DUMMY PART NUMBER
C5403	2113945A05	CAP CER CHP 470PF 50V 10%
C5404	2113944A15	CAP CER CHP 3.9PF 50V +/- 0.25
C5405	2113944A36	CAP CER CHP 68.0PF 50V 5%
C5406	2113945C31	CAP,FXD,.1UF,+10%,-10%,50V-DC,
C5407	2113944A28	CAP CER CHP 18.0PF 50V 5%
C5408	2113945B04	CAP,FXD,.022UF,+10%,-10%,25V-D
C5409	2113944A20	CAP CER CHP 6.2PF 50V +/- 0.5P
C5410	2113945B04	CAP,FXD,.022UF,+10%,-10%,25V-D
C5411	2113944A02	CAP CER CHP 1.2PF 50V +/- 0.25
C5412	2113944A34	CAP CER CHP 56.0PF 50V 5%
C5413	NOTPLACED	GCAM DUMMY PART NUMBER
C5414	2113944A20	CAP CER CHP 6.2PF 50V +/- 0.5P
C5415	2113944A15	CAP CER CHP 3.9PF 50V +/- 0.25
C5416	2115938H02	CAP CHIP CL1 22+/-5%PF
C5417	2113945C27	CAP,FXD,.047UF,+10%,-10%,50V-D
C5418	2113944A34	CAP CER CHP 56.0PF 50V 5%
C5419	2113944A34	CAP CER CHP 56.0PF 50V 5%
C5420	2113945B02	CAP CER CHP 10,000PF 25V 10%
C5421	2313960C26	CAP TANT 1.0 UF 10% 35V 3528-2
C5422	2113945C31	CAP,FXD,.1UF,+10%,-10%,50V-DC,
C5423	NOTPLACED	GCAM DUMMY PART NUMBER
C5424	NOTPLACED	GCAM DUMMY PART NUMBER
C5425	2113944A36	CAP CER CHP 68.0PF 50V 5%
C5426	2103689A47	SL240J HIGH - Q CAPACITOR, UCN
C5427	NOTPLACED	GCAM DUMMY PART NUMBER
C5428	2113945L49	CAP,FXD,.01UF,+5%,-5%,50V-DC,
C5429	2113944A34	CAP CER CHP 56.0PF 50V 5%
C5430	2113944C39	CAP CER CHP 56.0PF 50V 5%

Reference	Motorola PN	Value
C5431	2113944C32	CAP CER CHP 15.0PF 50V 5%
C5432	NOTPLACED	GCAM DUMMY PART NUMBER
C5433	NOTPLACED	GCAM DUMMY PART NUMBER
C5434	NOTPLACED	GCAM DUMMY PART NUMBER
C5435	2111078B22	CAP CHIP RF 22 5 NPO 100V
C5436	2111078B20	CAP CHIP RF 18 5 NPO 100V
C5437	NOTPLACED	GCAM DUMMY PART NUMBER
C5438	2111078B13	CAP ALT E16
C5439	NOTPLACED	GCAM DUMMY PART NUMBER
C5440	2111078B49	CAP CHIP RF 180 5 NPO 100V
C5441	2113944A36	CAP CER CHP 68.0PF 50V 5%
C5442	NOTPLACED	GCAM DUMMY PART NUMBER
C5443	2113944A22	CAP CER CHP 7.5PF 50V +/- 0.5P
C5444	2113944A22	CAP CER CHP 7.5PF 50V +/- 0.5P
C5445	2113944A22	CAP CER CHP 7.5PF 50V +/- 0.5P
C5446	2113944A22	CAP CER CHP 7.5PF 50V +/- 0.5P
C5447	2113944A22	CAP CER CHP 7.5PF 50V +/- 0.5P
C5448	2113944A22	CAP CER CHP 7.5PF 50V +/- 0.5P
C5449	2113944C39	CAP CER CHP 56.0PF 50V 5%
C5451	NOTPLACED	GCAM DUMMY PART NUMBER
C5452	NOTPLACED	GCAM DUMMY PART NUMBER
C5453	NOTPLACED	GCAM DUMMY PART NUMBER
C5455	NOTPLACED	GCAM DUMMY PART NUMBER
C5456	2111078B18	CAP CHIP RF 15 5 NPO 100V
C5457	NOTPLACED	GCAM DUMMY PART NUMBER
C5458	NOTPLACED	GCAM DUMMY PART NUMBER
C5459	NOTPLACED	GCAM DUMMY PART NUMBER
C5460	NOTPLACED	GCAM DUMMY PART NUMBER
C5461	2111078B25	CAP ALT E32
C5462	2111078B08	CAP CHIP RF 6.2 .25NPO 100V
C5463	NOTPLACED	GCAM DUMMY PART NUMBER
C5464	2111078B09	CAP ALT E17
C5465	NOTPLACED	GCAM DUMMY PART NUMBER
C5466	2111078B01	CAP CHIP RF 3.3 .25 NPO 100V
C5467	NOTPLACED	GCAM DUMMY PART NUMBER
C5468	2111078B13	CAP ALT E16
C5469	NOTPLACED	GCAM DUMMY PART NUMBER
C5470	NOTPLACED	GCAM DUMMY PART NUMBER
C5471	2111078B01	CAP CHIP RF 3.3 .25 NPO 100V
C5472	2111078B23	CAP ALT E37
C5473	2111078B34	CAP CHIP RF 47 5 NPO 100V
C5474	2113944A36	CAP CER CHP 68.0PF 50V 5%
C5475	2111078A29	CAPACITOR,CHIP,10PF,.5PF+/-,,,
C5480	2111078B49	CAP CHIP RF 180 5 NPO 100V
C5501	2113944C39	CAP CER CHP 56.0PF 50V 5%
C5502	2113944C39	CAP CER CHP 56.0PF 50V 5%
C5503	2113945B05	CAP,FXD,.033UF,+10%,-10%,25V-D

Reference	Motorola PN	Value
C5504	2313960G32	CAP,FXD,10UF,+10%,-10%,35V-DC,
C5505	2113945G57	CAP,FXD,.033UF,+5%,-5%,50V-DC,
C5506	2113944A34	CAP CER CHP 56.0PF 50V 5%
C5507	2113944A36	CAP CER CHP 68.0PF 50V 5%
C5508	2113944A36	CAP CER CHP 68.0PF 50V 5%
C5509	2113944A36	CAP CER CHP 68.0PF 50V 5%
C5510	2113944A36	CAP CER CHP 68.0PF 50V 5%
C5521	2113944A34	CAP CER CHP 56.0PF 50V 5%
C5541	2113944A34	CAP CER CHP 56.0PF 50V 5%
C5543	NOTPLACED	GCAM DUMMY PART NUMBER
C5550	2113944A36	CAP CER CHP 68.0PF 50V 5%
C5551	2113945A09	CAP CER CHP 1000PF 50V 10%
C5552	2113945A03	CAP CER CHP 330PF 50V 10%
C5553	2113944A36	CAP CER CHP 68.0PF 50V 5%
C5554	NOTPLACED	GCAM DUMMY PART NUMBER
C5555	2113944M04	CAP,FXD,2.7PF,.1PF+/-,50V-DC,0
C5556	2113944A33	CAP CER CHP 47.0PF 50V 5%
C5557	2113944A36	CAP CER CHP 68.0PF 50V 5%
C5558	NOTPLACED	GCAM DUMMY PART NUMBER
C5559	2113944A36	CAP CER CHP 68.0PF 50V 5%
C5601	2113944A36	CAP CER CHP 68.0PF 50V 5%
C5602	2113944A31	CAP CER CHP 33.0PF 50V 5%
C5603	2113944A23	CAP CER CHP 8.2PF 50V +/- 0.5P
C5604	2113944A08	CAP CER CHP 2.0PF 50V +/- 0.25
C5605	2113946K02	CAP CER CHP 0.10UF 16V
C5606	2113944A14	CAP CER CHP 3.6PF 50V +/- 0.25
C5607	2113944A15	CAP CER CHP 3.9PF 50V +/- 0.25
C5609	2113944A36	CAP CER CHP 68.0PF 50V 5%
C5611	2113944A13	CAP CER CHP 3.3PF 50V +/- 0.25
C5612	2113944A17	CAP CER CHP 4.7PF 50V +/- 0.25
C5613	2113944A08	CAP CER CHP 2.0PF 50V +/- 0.25
C5614	2113946K02	CAP CER CHP 0.10UF 16V
C5615	2113946K02	CAP CER CHP 0.10UF 16V
C5621	2113946K02	CAP CER CHP 0.10UF 16V
C5622	2113944A36	CAP CER CHP 68.0PF 50V 5%
C5623	NOTPLACED	GCAM DUMMY PART NUMBER
C5624	2113946K02	CAP CER CHP 0.10UF 16V
C5625	2113944A63	CAP,FXD,1PF,.25PF+/-,50V-DC,04
C5626	2113944A19	CAP CER CHP 5.6PF 50V +/- 0.5P
C5627	2113944A10	CAP CER CHP 2.4PF 50V +/- 0.25
C5629	2113946K02	CAP CER CHP 0.10UF 16V
C5630	2113944A36	CAP CER CHP 68.0PF 50V 5%
C5631	2113944A36	CAP CER CHP 68.0PF 50V 5%
C5632	2113944A05	CAP CER CHP 1.5PF 50V +/- 0.25
C5633	2113944A36	CAP CER CHP 68.0PF 50V 5%
C5634	2113944A36	CAP CER CHP 68.0PF 50V 5%
C5635	2113944A24	CAP CER CHP 9.1PF 50V +/- 0.5P

Reference	Motorola PN	Value
C5640	2113944A36	CAP CER CHP 68.0PF 50V 5%
C5641	NOTPLACED	GCAM DUMMY PART NUMBER
C5643	2113944A36	CAP CER CHP 68.0PF 50V 5%
C5644	2113944A36	CAP CER CHP 68.0PF 50V 5%
C5645	2113944A36	CAP CER CHP 68.0PF 50V 5%
C5646	2113944A36	CAP CER CHP 68.0PF 50V 5%
C5651	2313960D07	CAP,FXD,10,+10,-10,16,SM,-55M
C5652	2113946K02	CAP CER CHP 0.10UF 16V
C5653	2113945C04	CAP CER CHP 22,000PF 50V 10%
C5654	2113945L25	CAP,FXD,1000PF,+5%,-5%,50V-DC,
C5655	2113944A13	CAP CER CHP 3.3PF 50V +/- 0.25
C5671	2313960D07	CAP,FXD,10,+10,-10,16,SM,-55M
C5672	2313960D07	CAP,FXD,10,+10,-10,16,SM,-55M
C5681	2313960D07	CAP,FXD,10,+10,-10,16,SM,-55M
C5682	2313960D07	CAP,FXD,10,+10,-10,16,SM,-55M
C5683	2113945A03	CAP CER CHP 330PF 50V 10%
C5684	NOTPLACED	GCAM DUMMY PART NUMBER
C5685	NOTPLACED	GCAM DUMMY PART NUMBER
C5686	2113944A36	CAP CER CHP 68.0PF 50V 5%
C5701	NOTPLACED	GCAM DUMMY PART NUMBER
C5702	2113944A33	CAP CER CHP 47.0PF 50V 5%
C5704	2113944A14	CAP CER CHP 3.6PF 50V +/- 0.25
C5705	2113944A22	CAP CER CHP 7.5PF 50V +/- 0.5P
C5706	2113944A17	CAP CER CHP 4.7PF 50V +/- 0.25
C5707	2113944A36	CAP CER CHP 68.0PF 50V 5%
C5708	NOTPLACED	GCAM DUMMY PART NUMBER
C5709	2113944A22	CAP CER CHP 7.5PF 50V +/- 0.5P
C5711	2113944A36	CAP CER CHP 68.0PF 50V 5%
C5712	2113944A36	CAP CER CHP 68.0PF 50V 5%
C5713	2113946K02	CAP CER CHP 0.10UF 16V
C5714	2113944A36	CAP CER CHP 68.0PF 50V 5%
C5715	2113946K02	CAP CER CHP 0.10UF 16V
C5716	2113944A36	CAP CER CHP 68.0PF 50V 5%
C5717	2113944A36	CAP CER CHP 68.0PF 50V 5%
C5721	NOTPLACED	GCAM DUMMY PART NUMBER
C5722	NOTPLACED	GCAM DUMMY PART NUMBER
C5725	NOTPLACED	GCAM DUMMY PART NUMBER
C5730	2113944A31	CAP CER CHP 33.0PF 50V 5%
C5731	2113946K02	CAP CER CHP 0.10UF 16V
C5732	2113944A36	CAP CER CHP 68.0PF 50V 5%
C5733	2113946K02	CAP CER CHP 0.10UF 16V
C5734	2113944A19	CAP CER CHP 5.6PF 50V +/- 0.5P
C5735	2113944A23	CAP CER CHP 8.2PF 50V +/- 0.5P
C5736	NOTPLACED	GCAM DUMMY PART NUMBER
C5737	2113944A17	CAP CER CHP 4.7PF 50V +/- 0.25
C5738	2113944A23	CAP CER CHP 8.2PF 50V +/- 0.5P
C5739	2113944A36	CAP CER CHP 68.0PF 50V 5%

Reference	Motorola PN	Value
C5740	2113944A26	CAP CER CHP 12.0PF 50V 5%
C5741	2113944A08	CAP CER CHP 2.0PF 50V +/- 0.25
C5742	2113946K02	CAP CER CHP 0.10UF 16V
C5743	2313960B28	CAP TANT 2.2 UF 10% 10V 3216-1
C5750	2113944A36	CAP CER CHP 68.0PF 50V 5%
C5751	2113944A36	CAP CER CHP 68.0PF 50V 5%
C5752	2113944A36	CAP CER CHP 68.0PF 50V 5%
C5753	2113944A36	CAP CER CHP 68.0PF 50V 5%
C5754	2113945A13	CAP CER CHP 4700PF 50V 10%
C5760	2113944A36	CAP CER CHP 68.0PF 50V 5%
C5803	2113944M38	CAP,FXD,68PF,+2%,-2%,50V-DC,06
C5804	2113944M38	CAP,FXD,68PF,+2%,-2%,50V-DC,06
C5805	2113944M13	CAP,FXD,6.2PF,1PF+/-,,50V-DC
C5806	2113944C69	CAP,FXD,1.8PF,1PF+/-,,50V-DC,0
C5807	2113944C16	CAP CER CHP 2.7PF 50V +/- 0.25
C5808	2113944M13	CAP,FXD,6.2PF,1PF+/-,,50V-DC
C5809	NOTPLACED	GCAM DUMMY PART NUMBER
C5810	NOTPLACED	GCAM DUMMY PART NUMBER
C5811	2113944C16	CAP CER CHP 2.7PF 50V +/- 0.25
C5812	2113944C16	CAP CER CHP 2.7PF 50V +/- 0.25
C5813	2113944M38	CAP,FXD,68PF,+2%,-2%,50V-DC,06
C5819	2113944M38	CAP,FXD,68PF,+2%,-2%,50V-DC,06
C5820	2113945D04	CAP CER CHP 100,000PF 25V 10%
C5822	2113944M38	CAP,FXD,68PF,+2%,-2%,50V-DC,06
C5823	2113945D04	CAP CER CHP 100,000PF 25V 10%
C5824	2113944M38	CAP,FXD,68PF,+2%,-2%,50V-DC,06
C5825	NOTPLACED	GCAM DUMMY PART NUMBER
C5826	2113945D04	CAP CER CHP 100,000PF 25V 10%
C5827	2113945D04	CAP CER CHP 100,000PF 25V 10%
C5828	2113945D04	CAP CER CHP 100,000PF 25V 10%
C5831	2113944M38	CAP,FXD,68PF,+2%,-2%,50V-DC,06
C5833	2113945D04	CAP CER CHP 100,000PF 25V 10%
C5834	2113945D04	CAP CER CHP 100,000PF 25V 10%
C5836	2113945D04	CAP CER CHP 100,000PF 25V 10%
C5840	2113945D04	CAP CER CHP 100,000PF 25V 10%
C5841	2113945D04	CAP CER CHP 100,000PF 25V 10%
C5842	2113945D04	CAP CER CHP 100,000PF 25V 10%
C5843	2113945C04	CAP CER CHP 22,000PF 50V 10%
C5844	2113945C04	CAP CER CHP 22,000PF 50V 10%
C5845	2113944M38	CAP,FXD,68PF,+2%,-2%,50V-DC,06
C5846	2113944M38	CAP,FXD,68PF,+2%,-2%,50V-DC,06
C5847	2113945L25	CAP,FXD,1000PF,+5%,-5%,50V-DC,
C5848	2113945D04	CAP CER CHP 100,000PF 25V 10%
C5849	2113945D04	CAP CER CHP 100,000PF 25V 10%
C5850	2113945D04	CAP CER CHP 100,000PF 25V 10%
C5852	2113945L37	CAP,FXD,3300PF,+5%,-5%,50V-DC,
C5853	2113945L41	CAP,FXD,4700PF,+5%,-5%,50V-DC,

Reference	Motorola PN	Value
C5854	2113944M38	CAP,FXD,68PF,+2%,-2%,50V-DC,06
C5855	2113944M38	CAP,FXD,68PF,+2%,-2%,50V-DC,06
C5856	2113944C06	CAP CER CHP 470.0PF 50V 5%
C5857	2113944C06	CAP CER CHP 470.0PF 50V 5%
C5859	2113945L41	CAP,FXD,4700PF,+5%,-5%,50V-DC,
C5860	NOTPLACED	GCAM DUMMY PART NUMBER
C5861	NOTPLACED	GCAM DUMMY PART NUMBER
C5862	2113944M38	CAP,FXD,68PF,+2%,-2%,50V-DC,06
C5863	2113944M38	CAP,FXD,68PF,+2%,-2%,50V-DC,06
C5864	2113945D04	CAP CER CHP 100,000PF 25V 10%
C5865	2113944M38	CAP,FXD,68PF,+2%,-2%,50V-DC,06
C5867	2113944M38	CAP,FXD,68PF,+2%,-2%,50V-DC,06
C5868	2113944M38	CAP,FXD,68PF,+2%,-2%,50V-DC,06
C5870	2113944M38	CAP,FXD,68PF,+2%,-2%,50V-DC,06
C5871	2113944C03	CAP CER CHP 270.0PF 50V 5%
C5872	2113944C03	CAP CER CHP 270.0PF 50V 5%
C5873	2113944C03	CAP CER CHP 270.0PF 50V 5%
C5874	2113944C03	CAP CER CHP 270.0PF 50V 5%
C5875	2313960B01	CAP,FXD,1UF,+10%,-10%,16V-DC,S
C5876	2113944M38	CAP,FXD,68PF,+2%,-2%,50V-DC,06
C5878	2113944M03	CAP,FXD,2.4PF,1PF+/-,,50V-DC
C5879	NOTPLACED	GCAM DUMMY PART NUMBER
C5880	NOTPLACED	GCAM DUMMY PART NUMBER
C5881	2113944M38	CAP,FXD,68PF,+2%,-2%,50V-DC,06
C5882	NOTPLACED	GCAM DUMMY PART NUMBER
C5883	2113945D04	CAP CER CHP 100,000PF 25V 10%
D0101	4813978C02	PB FREE, NOT COMPLETELY ENRICH
D0102	4813978C02	PB FREE, NOT COMPLETELY ENRICH
D0150	NOTPLACED	GCAM DUMMY PART NUMBER
D0151	NOTPLACED	GCAM DUMMY PART NUMBER
D0152	4813978C02	PB FREE, NOT COMPLETELY ENRICH
D0153	NOTPLACED	GCAM DUMMY PART NUMBER
D0300	4813978C02	PB FREE, NOT COMPLETELY ENRICH
D0301	4813978C02	PB FREE, NOT COMPLETELY ENRICH
D0303	4813978C02	PB FREE, NOT COMPLETELY ENRICH
D0304	4813978C02	PB FREE, NOT COMPLETELY ENRICH
D0305	4813974A21	DIODE ARRAY,SIGNL/SWG,BAS70-04
D0306	4813978C02	PB FREE, NOT COMPLETELY ENRICH
D0325	4813978C02	PB FREE, NOT COMPLETELY ENRICH

Reference	Motorola PN	Value
D0404	4866544A01	DIODE ARRAY,ZEN,SR05.TCT,SM,,,
D1101	4813978C02	PB FREE, NOT COMPLETELY ENRICH
D5001	4813974A06	DIODE,PIN,SM,SOT-23,35V,.2W,SL
D5002	4815048H01	SOT MMBD353 DIODE DUAL SCHT
D5003	4813974A06	DIODE,PIN,SM,SOT-23,35V,.2W,SL
D5004	4813974A06	DIODE,PIN,SM,SOT-23,35V,.2W,SL
D5121	4815048H01	SOT MMBD353 DIODE DUAL SCHT
D5180	4885055Y01	DIODE VARACTOR PB-FREE
D5190	4813974A01	DIODE ARRAY,VCTR,SM,SOT-23,100
D5201	NOTPLACED	GCAM DUMMY PART NUMBER
D5202	NOTPLACED	GCAM DUMMY PART NUMBER
D5301	4815011H01	DIODE TRIPLE
D5302	4815011H01	DIODE TRIPLE
D5331	4813974A05	DIODE 30V HOT CARRIER MMBD301L
D5451	4802482J02	PIN DIODE SMD
D5452	NOTPLACED	GCAM DUMMY PART NUMBER
D5551	4802482J02	PIN DIODE SMD
D5601	NOTPLACED	GCAM DUMMY PART NUMBER
D5602	4885055Y01	DIODE VARACTOR PB-FREE
D5603	NOTPLACED	GCAM DUMMY PART NUMBER
D5604	4885055Y01	DIODE VARACTOR PB-FREE
D5731	NOTPLACED	GCAM DUMMY PART NUMBER
D5732	4885055Y01	DIODE VARACTOR PB-FREE
D5733	NOTPLACED	GCAM DUMMY PART NUMBER
D5734	4885055Y01	DIODE VARACTOR PB-FREE
E0300	2415954H01	INDUCTOR BEAD CHIP
E1101	2480067M02	CHK RF CHIP BEAD INDUCTOR
E1102	2480067M02	CHK RF CHIP BEAD INDUCTOR
E1103	2480067M02	CHK RF CHIP BEAD INDUCTOR
E5801	NOTPLACED	GCAM DUMMY PART NUMBER
F0301	NOTPLACED	GCAM DUMMY PART NUMBER
F0302	6515076H01	FUSE CHIP SMT TR/1608FF 3A
F0303	NOTPLACED	GCAM DUMMY PART NUMBER
FL0200	5185941F33	IC,3V LNR PCM CODEC FLTR,NOPB
FL5001	9186076Z01	FILTER, BP 3-POLE CER 851-870
FL5002	9186076Z01	FILTER, BP 3-POLE CER 851-870
FL5451	5866506A01	ISOLATOR 806-870MHZ 10W FOR-WAR
J0301	0986165B02	POWER CONNECTOR MILLENIUM
J0400	0966512A01	20 POS. 0.64 SQ CONNECTOR
J0450	0915064H03	CONNECTOR, ZIF (40 PINS)
J0500	0915064H03	CONNECTOR, ZIF (40 PINS)
J0550	0916162H02	12 POS, FLEX CONNECTOR, SIDE E

Reference	Motorola PN	Value
J0570	NOTPLACED	GCAM DUMMY PART NUMBER
J0600	0980521Z04	CONN, ZIF VERTICAL, 24PINS
J5401	0986166B01	MOBILE RF CONNECTOR (BNC)
L0231	2415954H01	INDUCTOR BEAD CHIP
L0232	2415954H01	INDUCTOR BEAD CHIP
L0301	NOTPLACED	GCAM DUMMY PART NUMBER
L5001	2414032F22	IDCTR,WW,8.2NH,5%,600MA,.12O HM
L5002	2414017Q20	IDCTR,FXD,2.2UH,20%,30MA,.65O H
L5004	2414032F26	IDCTR,WW,22NH,5%,500MA,.22OH M,
L5005	2414032F22	IDCTR,WW,8.2NH,5%,600MA,.12O HM
L5006	2414032F23	IDCTR,WW,12NH,5%,600MA,.15OH M,
L5007	2414032F28	IDCTR,WW,33NH,5%,500MA,.27OH M,
L5008	2414032F21	IDCTR,WW,6.8NH,5%,600MA,.11O HM
L5009	2414017G06	IDCTR,CHIP,8.2NH,5%,300MA,.33O
L5011	2414032F43	IDCTR,WW,560NH,10%,170MA,3.5 OH
L5012	2414032F59	IDCTR,WW,390NH,5%,290MA,1.5O HM
L5013	2414017G08	IND 12.0 NH 5%
L5014	2414017G08	IND 12.0 NH 5%
L5015	2414032F38	IDCTR,WW,220NH,5%,400MA,.7OH M,
L5016	2414032F38	IDCTR,WW,220NH,5%,400MA,.7OH M,
L5017	2414017G08	IND 12.0 NH 5%
L5018	2414032F38	IDCTR,WW,220NH,5%,400MA,.7OH M,
L5019	2488090Y11	INDUCTOR,MULTI- LAYER,6.8NH,1005
L5126	2414032D23	IDCTR,WW,470NH,5%,490MA,1.3O HM
L5174	2409092R07	IND CHIP PWR 1008 10 UH SMD
L5175	2409092R07	IND CHIP PWR 1008 10 UH SMD
L5180	2414032D19	IDCTR,WW,220NH,5%,670MA,.5OH M,
L5190	2414032D30	IDCTR,WW,1UH,5%,320MA,2.8OH M,C
L5201	2414032B57	IDCTR,WW,220NH,5%,720MA,.84O HM
L5202	NOTPLACED	GCAM DUMMY PART NUMBER
L5203	2414032F38	IDCTR,WW,220NH,5%,400MA,.7OH M,
L5204	2414032B57	IDCTR,WW,220NH,5%,720MA,.84O HM
L5218	NOTPLACED	GCAM DUMMY PART NUMBER

Reference	Motorola PN	Value
L5219	2414015B08	IDCTR,CHIP,220NH,2%,400MA,.7O H
L5301	2414017Q20	IDCTR,FXD,2.2UH,20%,30MA,.65O H
L5361	2414017Q20	IDCTR,FXD,2.2UH,20%,30MA,.65O H
L5362	2414032F23	IDCTR,WW,12NH,5%,600MA,.15OH M,
L5363	2414032L25	IDCTR,WW,12UH,5%,150MA,3.8OH M,
L5403	2414032F38	IDCTR,WW,220NH,5%,400MA,.7OH M,
L5404	2414032F22	IDCTR,WW,8.2NH,5%,600MA,.12O HM
L5405	2414032F22	IDCTR,WW,8.2NH,5%,600MA,.12O HM
L5421	2479990B02	AIR WOUND COIL/GREEN COLOR 19.
L5431	2485873L01	ENCAPSULATED AIR WOUND COIL
L5451	2460591A49	COIL AIR WOUND INDUC 8.01
L5452	2460591A49	COIL AIR WOUND INDUC 8.01
L5453	NOTPLACED	GCAM DUMMY PART NUMBER
L5461	2460591A29	COIL AIR WOUND INDUC 6.61
L5462	2460591A29	COIL AIR WOUND INDUC 6.61
L5501	2484657R01	INDUCTOR BEAD CHIP
L5502	2484657R01	INDUCTOR BEAD CHIP
L5503	2484657R01	INDUCTOR BEAD CHIP
L5551	2414032F38	IDCTR,WW,220NH,5%,400MA,.7OH M,
L5552	2414032F38	IDCTR,WW,220NH,5%,400MA,.7OH M,
L5553	2414032F38	IDCTR,WW,220NH,5%,400MA,.7OH M,
L5601	2414032F38	IDCTR,WW,220NH,5%,400MA,.7OH M,
L5603	2414032F25	IDCTR,WW,18NH,5%,600MA,.2OH M,C
L5604	2414032F38	IDCTR,WW,220NH,5%,400MA,.7OH M,
L5605	2414032F38	IDCTR,WW,220NH,5%,400MA,.7OH M,
L5606	2414032F38	IDCTR,WW,220NH,5%,400MA,.7OH M,
L5607	2414032F22	IDCTR,WW,8.2NH,5%,600MA,.12O HM
L5623	2414032F27	IDCTR,FXD,27NH,5%,500MA,.25O HM
L5627	NOTPLACED	GCAM DUMMY PART NUMBER
L5628	2414032F24	IDCTR,WW,15NH,5%,600MA,.17OH M,
L5702	NOTPLACED	GCAM DUMMY PART NUMBER

Reference	Motorola PN	Value
L5703	2414032F22	IDCTR,WW,8.2NH,5%,600MA,.12O HM
L5704	NOTPLACED	GCAM DUMMY PART NUMBER
L5711	2414032F28	IDCTR,WW,33NH,5%,500MA,.27OH M,
L5712	2414032F41	IDCTR,WW,390NH,10%,200MA,1.5 OH
L5721	2414032F21	IDCTR,WW,6.8NH,5%,600MA,.11O HM
L5722	2414032F38	IDCTR,WW,220NH,5%,400MA,.7OH M,
L5731	2414032F38	IDCTR,WW,220NH,5%,400MA,.7OH M,
L5733	2414032F25	IDCTR,WW,18NH,5%,600MA,.2OH M,C
L5734	2414032F38	IDCTR,WW,220NH,5%,400MA,.7OH M,
L5735	2414032F38	IDCTR,WW,220NH,5%,400MA,.7OH M,
L5803	2414032F21	IDCTR,WW,6.8NH,5%,600MA,.11O HM
L5804	2414032F21	IDCTR,WW,6.8NH,5%,600MA,.11O HM
L5805	2414032F21	IDCTR,WW,6.8NH,5%,600MA,.11O HM
L5812	2580443L24	XFMR,BALUN,,,SM
L5813	2414015A13	IDCTR,CHIP,560NH,2%,580MA,1.33
L5814	2414017Q20	IDCTR,FXD,2.2UH,20%,30MA,.65O H
L5877	2415429H25	CHIP INDUCTOR
M0301	NOTPLACED	GCAM DUMMY PART NUMBER
M0302	NOTPLACED	GCAM DUMMY PART NUMBER
M5421	2686201B02	HEATSPREADER
M5422	2686201B02	HEATSPREADER
Q0100	4813973M07	XSTR,BIP GP SS,,NPN,,TO-236,,,
Q0101	NOTPLACED	GCAM DUMMY PART NUMBER
Q0150	4815066H01	UMG5N DIGITAL TRANSISTOR
Q0152	4815066H01	UMG5N DIGITAL TRANSISTOR
Q0156	4813973A42	XSTR,BIP GP SS,,NPN,,SM,SC-59,
Q0157	4813973A42	XSTR,BIP GP SS,,NPN,,SM,SC-59,
Q0158	4813973A42	XSTR,BIP GP SS,,NPN,,SM,SC-59,
Q0159	4816147H01	TSTR NPN DRLNGTN MXTA27
Q0160	4813973A42	XSTR,BIP GP SS,,NPN,,SM,SC-59,
Q0161	4813973A81	XSTR,BIP GP SS,DIG,NPN AND PNP
Q0163	4813973A42	XSTR,BIP GP SS,,NPN,,SM,SC-59,
Q0164	4813973M07	XSTR,BIP GP SS,,NPN,,TO-236,,,
Q0200	4813973A42	XSTR,BIP GP SS,,NPN,,SM,SC-59,
Q0201	4815066H01	UMG5N DIGITAL TRANSISTOR
Q0202	4813973A42	XSTR,BIP GP SS,,NPN,,SM,SC-59,
Q0203	4813973A42	XSTR,BIP GP SS,,NPN,,SM,SC-59,

Reference	Motorola PN	Value
Q0301	4813973A81	XSTR,BIP GP SS,DIG,NPN AND PNP
Q0302	4813973M07	XSTR,BIP GP SS,,NPN,,TO-236,,,
Q0303	4813973A42	XSTR,BIP GP SS,,NPN,,SM,SC-59,
Q0304	4813973A42	XSTR,BIP GP SS,,NPN,,SM,SC-59,
Q0305	4813973M07	XSTR,BIP GP SS,,NPN,,TO-236,,,
Q0306	4813973M07	XSTR,BIP GP SS,,NPN,,TO-236,,,
Q0341	4813973A13	XSTR,BIP GP SS,,PNP,,TO-236,SO
Q0342	4813973A42	XSTR,BIP GP SS,,NPN,,SM,SC-59,
Q0343	4813973M07	XSTR,BIP GP SS,,NPN,,TO-236,,,
Q0344	4813973A13	XSTR,BIP GP SS,,PNP,,TO-236,SO
Q0401	NOTPLACED	GCAM DUMMY PART NUMBER
Q0600	5166540A01	IC,POWER MANAGE- MENT,,SM,,,PB-
Q5001	4813973M07	XSTR,BIP GP SS,,NPN,,TO-236,,,
Q5002	4816097H01	XISTOR FMC2 RH
Q5101	4802197J95	RF TRANSISTOR PBR941
Q5151	NOTPLACED	GCAM DUMMY PART NUMBER
Q5180	4802197J95	RF TRANSISTOR PBR941
Q5190	4802197J95	RF TRANSISTOR PBR941
Q5201	4802197J95	RF TRANSISTOR PBR941
Q5202	NOTPLACED	GCAM DUMMY PART NUMBER
Q5301	4815066H01	UMG5N DIGITAL TRANSISTOR
Q5331	4813973A42	XSTR,BIP GP SS,,NPN,,SM,SC-59,
Q5332	4813973A13	XSTR,BIP GP SS,,PNP,,TO-236,SO
Q5351	4802197J95	RF TRANSISTOR PBR941
Q5352	4813973A13	XSTR,BIP GP SS,,PNP,,TO-236,SO
Q5421	4813976A03	TSTR, 450 MHZ, 8W, 7.5V, PLD 1
Q5431	4888606T14	XSTR,FET RF POWER,TO- 270,45W,T
Q5501	4813973A13	XSTR,BIP GP SS,,PNP,,TO-236,SO
Q5521	4813973A13	XSTR,BIP GP SS,,PNP,,TO-236,SO
Q5542	4813973A13	XSTR,BIP GP SS,,PNP,,TO-236,SO
Q5551	4813973A13	XSTR,BIP GP SS,,PNP,,TO-236,SO
Q5552	4813973A42	XSTR,BIP GP SS,,NPN,,SM,SC-59,
Q5553	4813973A13	XSTR,BIP GP SS,,PNP,,TO-236,SO
Q5554	4813973A42	XSTR,BIP GP SS,,NPN,,SM,SC-59,
Q5559	4813973M07	XSTR,BIP GP SS,,NPN,,TO-236,,,
Q5601	4885061Y01	XSTR NPN 6V 30UA 12GHZ PB- FREE
Q5602	4813973A42	XSTR,BIP GP SS,,NPN,,SM,SC-59,
Q5604	4815267H01	DBRT UMT1NFTN
Q5605	4815267H01	DBRT UMT1NFTN
Q5621	4885061Y01	XSTR NPN 6V 30UA 12GHZ PB- FREE
Q5631	4885061Y01	XSTR NPN 6V 30UA 12GHZ PB- FREE
Q5653	4815154H01	DUAL TRANS NPN
Q5671	4813973M07	XSTR,BIP GP SS,,NPN,,TO-236,,,

Reference	Motorola PN	Value
Q5681	4813973M07	XSTR,BIP GP SS,,NPN,,TO-236,,,
Q5701	4885061Y01	XSTR NPN 6V 30UA 12GHZ PB-FREE
Q5711	4815055H01	TSTR DUAL NPN/PNP UMH 5
Q5712	4885061Y01	XSTR NPN 6V 30UA 12GHZ PB-FREE
Q5801	4802197J95	RF TRANSISTOR PBR941
Q5802	4815066H01	UMG5N DIGITAL TRANSISTOR
Q5804	4813973A13	XSTR,BIP GP SS,,PNP,,TO-236,,SO
R0100	0613952H89	CER CHIP RES 4700 OHM 5% 0603
R0101	0613952H89	CER CHIP RES 4700 OHM 5% 0603
R0102	0613952H89	CER CHIP RES 4700 OHM 5% 0603
R0105	0613952H25	CER CHIP RES 10.0 OHM 5% 0603
R0106	0613952J17	CER CHIP RES 47K OHM 5% 0603
R0107	NOTPLACED	GCAM DUMMY PART NUMBER
R0108	0613952J17	CER CHIP RES 47K OHM 5% 0603
R0111	0613952H25	CER CHIP RES 10.0 OHM 5% 0603
R0113	0613952J01	CER CHIP RES 10K OHM 5% 0603
R0115	0613952J22	CER CHIP RES 75K OHM 5 0603
R0117	0613952J12	CER CHIP RES 30K OHM 5 0603
R0118	0613952J05	CER CHIP RES 15K OHM 5% 0603
R0119	0613952J01	CER CHIP RES 10K OHM 5% 0603
R0120	0613952H89	CER CHIP RES 4700 OHM 5% 0603
R0122	NOTPLACED	GCAM DUMMY PART NUMBER
R0125	0613952H77	CER CHIP RES 1500 OHM 5% 0603
R0127	NOTPLACED	GCAM DUMMY PART NUMBER
R0128	0613952H77	CER CHIP RES 1500 OHM 5% 0603
R0129	0613952J17	CER CHIP RES 47K OHM 5% 0603
R0130	NOTPLACED	GCAM DUMMY PART NUMBER
R0131	NOTPLACED	GCAM DUMMY PART NUMBER
R0132	0613952H67	CER CHIP RES 560 OHM 5% 0603
R0133	0613952J13	CER CHIP RES 33K OHM 5% 0603
R0134	0613952H77	CER CHIP RES 1500 OHM 5% 0603
R0135	NOTPLACED	GCAM DUMMY PART NUMBER
R0136	0613952J17	CER CHIP RES 47K OHM 5% 0603
R0150	0613952J17	CER CHIP RES 47K OHM 5% 0603
R0151	NOTPLACED	GCAM DUMMY PART NUMBER
R0152	NOTPLACED	GCAM DUMMY PART NUMBER
R0153	0613952J17	CER CHIP RES 47K OHM 5% 0603
R0154	0613952H81	CER CHIP RES 2200 OHM 5% 0603
R0155	0613952H81	CER CHIP RES 2200 OHM 5% 0603
R0156	NOTPLACED	GCAM DUMMY PART NUMBER
R0157	NOTPLACED	GCAM DUMMY PART NUMBER
R0159	0613952J17	CER CHIP RES 47K OHM 5% 0603
R0160	0613952H89	CER CHIP RES 4700 OHM 5% 0603
R0161	0613952J17	CER CHIP RES 47K OHM 5% 0603
R0162	0613952J17	CER CHIP RES 47K OHM 5% 0603
R0163	0613952J17	CER CHIP RES 47K OHM 5% 0603

Reference	Motorola PN	Value
R0165	0613952H89	CER CHIP RES 4700 OHM 5% 0603
R0166	0613952J01	CER CHIP RES 10K OHM 5% 0603
R0167	0613952J17	CER CHIP RES 47K OHM 5% 0603
R0168	0613952J01	CER CHIP RES 10K OHM 5% 0603
R0169	NOTPLACED	GCAM DUMMY PART NUMBER
R0170	0613952J01	CER CHIP RES 10K OHM 5% 0603
R0171	0613952J05	CER CHIP RES 15K OHM 5% 0603
R0172	0613952J07	CER CHIP RES 18K OHM 5% 0603
R0173	0613952H81	CER CHIP RES 2200 OHM 5% 0603
R0174	NOTPLACED	GCAM DUMMY PART NUMBER
R0175	0613952J01	CER CHIP RES 10K OHM 5% 0603
R0176	0613952J17	CER CHIP RES 47K OHM 5% 0603
R0177	NOTPLACED	GCAM DUMMY PART NUMBER
R0178	0613952J25	CER CHIP RES 100K OHM 5% 0603
R0179	NOTPLACED	GCAM DUMMY PART NUMBER
R0180	NOTPLACED	GCAM DUMMY PART NUMBER
R0181	NOTPLACED	GCAM DUMMY PART NUMBER
R0182	0613952J25	CER CHIP RES 100K OHM 5% 0603
R0200	0613952H67	CER CHIP RES 560 OHM 5% 0603
R0201	0613952H49	CER CHIP RES 100 OHM 5% 0603
R0202	0613952H49	CER CHIP RES 100 OHM 5% 0603
R0203	0613952H67	CER CHIP RES 560 OHM 5% 0603
R0204	0613952J32	CER CHIP RES 200K OHM 5 0603
R0205	0613952J32	CER CHIP RES 200K OHM 5 0603
R0206	0613952J17	CER CHIP RES 47K OHM 5% 0603
R0207	0613952J17	CER CHIP RES 47K OHM 5% 0603
R0208	0613952J17	CER CHIP RES 47K OHM 5% 0603
R0218	0613952J01	CER CHIP RES 10K OHM 5% 0603
R0220	0613952H73	CER CHIP RES 1000 OHM 5% 0603
R0221	0613952H49	CER CHIP RES 100 OHM 5% 0603
R0222	0613952J01	CER CHIP RES 10K OHM 5% 0603
R0223	0613952H89	CER CHIP RES 4700 OHM 5% 0603
R0224	0613952J05	CER CHIP RES 15K OHM 5% 0603
R0225	0613952H73	CER CHIP RES 1000 OHM 5% 0603
R0228	0613952J01	CER CHIP RES 10K OHM 5% 0603
R0237	0613952J05	CER CHIP RES 15K OHM 5% 0603
R0238	0613952J11	CER CHIP RES 27K OHM 5% 0603
R0239	0613952J03	CER CHIP RES 12K OHM 5% 0603
R0240	0613952J25	CER CHIP RES 100K OHM 5% 0603
R0241	0613952J05	CER CHIP RES 15K OHM 5% 0603
R0242	0613952J35	CER CHIP RES 270K OHM 5% 0603
R0243	0613952J11	CER CHIP RES 27K OHM 5% 0603
R0244	0613952J01	CER CHIP RES 10K OHM 5% 0603
R0245	0613952H85	CER CHIP RES 3300 OHM 5% 0603

Reference	Motorola PN	Value
R0246	NOTPLACED	GCAM DUMMY PART NUMBER
R0300	0613952H73	CER CHIP RES 1000 OHM 5% 0603
R0301	0613952J22	CER CHIP RES 75K OHM 5 0603
R0302	0613952H95	CER CHIP RES 8200 OHM 5% 0603
R0303	0613952J17	CER CHIP RES 47K OHM 5% 0603
R0304	0613952H89	CER CHIP RES 4700 OHM 5% 0603
R0305	0613958D85	CER CHIP RES 7500 OHM 1% 0805
R0306	0613958D09	CER CHIP RES 1210 OHM 1% 0805
R0307	0613958D85	CER CHIP RES 7500 OHM 1% 0805
R0308	0613958D09	CER CHIP RES 1210 OHM 1% 0805
R0309	0613952J01	CER CHIP RES 10K OHM 5% 0603
R0310	0613952J17	CER CHIP RES 47K OHM 5% 0603
R0311	0613952H77	CER CHIP RES 1500 OHM 5% 0603
R0312	0613952E66	CER CHIP RES 47.5K OHM 1 0603
R0313	0613952E09	CER CHIP RES 12.1K OHM 1% 0603
R0314	0613952H73	CER CHIP RES 1000 OHM 5% 0603
R0318	0613952E66	CER CHIP RES 47.5K OHM 1 0603
R0319	0613952E10	CER CHIP RES 12.1K OHM 1% 0603
R0320	0613952J17	CER CHIP RES 47K OHM 5% 0603
R0321	NOTPLACED	GCAM DUMMY PART NUMBER
R0322	0613952J17	CER CHIP RES 47K OHM 5% 0603
R0323	0613952G67	CER CHIP RES 0.0 +/-0.050 OHM
R0324	NOTPLACED	GCAM DUMMY PART NUMBER
R0325	0613952H89	CER CHIP RES 4700 OHM 5% 0603
R0326	0613952G67	CER CHIP RES 0.0 +/-0.050 OHM
R0327	NOTPLACED	GCAM DUMMY PART NUMBER
R0328	NOTPLACED	GCAM DUMMY PART NUMBER
R0330	NOTPLACED	GCAM DUMMY PART NUMBER
R0331	NOTPLACED	GCAM DUMMY PART NUMBER
R0332	NOTPLACED	GCAM DUMMY PART NUMBER
R0341	0613952H89	CER CHIP RES 4700 OHM 5% 0603
R0342	0613952J25	CER CHIP RES 100K OHM 5% 0603
R0343	0613952J17	CER CHIP RES 47K OHM 5% 0603
R0344	0613952J17	CER CHIP RES 47K OHM 5% 0603
R0345	0613952J01	CER CHIP RES 10K OHM 5% 0603
R0346	0613952J17	CER CHIP RES 47K OHM 5% 0603
R0347	NOTPLACED	GCAM DUMMY PART NUMBER
R0348	0613952G67	CER CHIP RES 0.0 +/-0.050 OHM
R0349	0613952H49	CER CHIP RES 100 OHM 5% 0603
R0350	NOTPLACED	GCAM DUMMY PART NUMBER
R0400	0613952J17	CER CHIP RES 47K OHM 5% 0603
R0401	NOTPLACED	GCAM DUMMY PART NUMBER
R0402	0613952H89	CER CHIP RES 4700 OHM 5% 0603
R0403	0613952J01	CER CHIP RES 10K OHM 5% 0603
R0404	0613952H89	CER CHIP RES 4700 OHM 5% 0603

Reference	Motorola PN	Value
R0405	0613952H75	CER CHIP RES 1200 OHM 5% 0603
R0406	0613952J01	CER CHIP RES 10K OHM 5% 0603
R0409	0613952H67	CER CHIP RES 560 OHM 5% 0603
R0410	0613952J25	CER CHIP RES 100K OHM 5% 0603
R0411	0613952H33	CER CHIP RES 22.0 OHM 5% 0603
R0412	0613952H33	CER CHIP RES 22.0 OHM 5% 0603
R0413	0613952J01	CER CHIP RES 10K OHM 5% 0603
R0415	0613952H49	CER CHIP RES 100 OHM 5% 0603
R0416	0613952H77	CER CHIP RES 1500 OHM 5% 0603
R0417	0613952H49	CER CHIP RES 100 OHM 5% 0603
R0418	0613952H49	CER CHIP RES 100 OHM 5% 0603
R0420	NOTPLACED	GCAM DUMMY PART NUMBER
R0421	NOTPLACED	GCAM DUMMY PART NUMBER
R0423	NOTPLACED	GCAM DUMMY PART NUMBER
R0424	NOTPLACED	GCAM DUMMY PART NUMBER
R0427	0613952G67	CER CHIP RES 0.0 +/-0.050 OHM
R0428	0613952J01	CER CHIP RES 10K OHM 5% 0603
R0450	0613952J17	CER CHIP RES 47K OHM 5% 0603
R0451	0613952J01	CER CHIP RES 10K OHM 5% 0603
R0452	0613952H81	CER CHIP RES 2200 OHM 5% 0603
R0454	0613952J13	CER CHIP RES 33K OHM 5% 0603
R0455	0613952J01	CER CHIP RES 10K OHM 5% 0603
R0456	NOTPLACED	GCAM DUMMY PART NUMBER
R0457	0613952G67	CER CHIP RES 0.0 +/-0.050 OHM
R0458	0613952J17	CER CHIP RES 47K OHM 5% 0603
R0459	0613952J01	CER CHIP RES 10K OHM 5% 0603
R0463	NOTPLACED	GCAM DUMMY PART NUMBER
R0464	NOTPLACED	GCAM DUMMY PART NUMBER
R0465	0613952G67	CER CHIP RES 0.0 +/-0.050 OHM
R0466	NOTPLACED	GCAM DUMMY PART NUMBER
R0467	0613952H89	CER CHIP RES 4700 OHM 5% 0603
R0468	0613952J25	CER CHIP RES 100K OHM 5% 0603
R0469	0613952H81	CER CHIP RES 2200 OHM 5% 0603
R0470	0613952J25	CER CHIP RES 100K OHM 5% 0603
R0473	0613952H59	CER CHIP RES 270 OHM 5% 0603
R0505	0613952H33	CER CHIP RES 22.0 OHM 5% 0603
R0527	0613952H89	CER CHIP RES 4700 OHM 5% 0603
R0555	0613952H65	CER CHIP RES 470 OHM 5% 0603
R0557	0613952H25	CER CHIP RES 10.0 OHM 5% 0603
R0559	0613952H25	CER CHIP RES 10.0 OHM 5% 0603
R0562	0613952G67	CER CHIP RES 0.0 +/-0.050 OHM
R0571	NOTPLACED	GCAM DUMMY PART NUMBER
R0600	NOTPLACED	GCAM DUMMY PART NUMBER
R0601	0613952G67	CER CHIP RES 0.0 +/-0.050 OHM
R0602	0613952G67	CER CHIP RES 0.0 +/-0.050 OHM

Reference	Motorola PN	Value
R0603	0613952G67	CER CHIP RES 0.0 +/-0.050 OHM
R0604	0613952J17	CER CHIP RES 47K OHM 5% 0603
R0605	0613952J01	CER CHIP RES 10K OHM 5% 0603
R1101	0613952J17	CER CHIP RES 47K OHM 5% 0603
R1102	0613952G67	CER CHIP RES 0.0 +/-0.050 OHM
R1103	0613952J01	CER CHIP RES 10K OHM 5% 0603
R1104	NOTPLACED	GCAM DUMMY PART NUMBER
R1105	NOTPLACED	GCAM DUMMY PART NUMBER
R1107	NOTPLACED	GCAM DUMMY PART NUMBER
R1108	0613952G67	CER CHIP RES 0.0 +/-0.050 OHM
R1109	0613952G67	CER CHIP RES 0.0 +/-0.050 OHM
R1111	NOTPLACED	GCAM DUMMY PART NUMBER
R1112	NOTPLACED	GCAM DUMMY PART NUMBER
R1113	NOTPLACED	GCAM DUMMY PART NUMBER
R1114	0613952G67	CER CHIP RES 0.0 +/-0.050 OHM
R1116	NOTPLACED	GCAM DUMMY PART NUMBER
R1131	0613952J25	CER CHIP RES 100K OHM 5% 0603
R1132	0613952J01	CER CHIP RES 10K OHM 5% 0603
R5001	0613952R01	CER CHIP RES 10K OHM 5% 0402
R5004	0613952Q46	CER CHIP RES 75.0 OHM 5 0402
R5006	0613952Q73	CER CHIP RES 1000 OHM 5 0402
R5007	0613952Q25	CER CHIP RES 10.0 OHM 5% 0402
R5009	0613952R66	CER CHIP RES 0.0 +/-0.050 OHM
R5010	0613952R01	CER CHIP RES 10K OHM 5% 0402
R5011	0613952Q73	CER CHIP RES 1000 OHM 5 0402
R5012	0613952R66	CER CHIP RES 0.0 +/-0.050 OHM
R5013	0613952R17	CER CHIP RES 47K OHM 5% 0402
R5014	0613952Q69	CER CHIP RES 680 OHM 5% 0402
R5015	0613952Q42	CER CHIP RES 51.0 OHM 5% 0402
R5017	0613952Q73	CER CHIP RES 1000 OHM 5 0402
R5018	0613952Q41	CER CHIP RES 47.0 OHM 5% 0402
R5019	0613952Q63	CER CHIP RES 390 OHM 5 0402
R5020	0613952Q63	CER CHIP RES 390 OHM 5 0402
R5021	0613952Q77	CER CHIP RES 1500 OHM 5% 0402
R5022	0613952Q59	CER CHIP RES 270 OHM 5 0402
R5023	0613952Q89	CER CHIP RES 4700 OHM 5 0402
R5024	0613952Q85	CER CHIP RES 3300 OHM 5% 0402
R5026	0613952Q25	CER CHIP RES 10.0 OHM 5% 0402
R5028	NOTPLACED	GCAM DUMMY PART NUMBER
R5100	0613952H42	CER CHIP RES 51.0 OHM 5% 0603
R5101	0613952J03	CER CHIP RES 12K OHM 5% 0603
R5102	0613952J11	CER CHIP RES 27K OHM 5% 0603
R5103	NOTPLACED	GCAM DUMMY PART NUMBER
R5104	0613952H71	CER CHIP RES 820 OHM 5% 0603
R5105	0613952H33	CER CHIP RES 22.0 OHM 5% 0603
R5106	0613952H41	CER CHIP RES 47.0 OHM 5% 0603

Reference	Motorola PN	Value
R5121	0613952H81	CER CHIP RES 2200 OHM 5% 0603
R5122	0613952H65	CER CHIP RES 470 OHM 5% 0603
R5125	0613952H67	CER CHIP RES 560 OHM 5% 0603
R5131	0613952H25	CER CHIP RES 10.0 OHM 5% 0603
R5132	0613952H25	CER CHIP RES 10.0 OHM 5% 0603
R5133	0613952H25	CER CHIP RES 10.0 OHM 5% 0603
R5134	0613952H25	CER CHIP RES 10.0 OHM 5% 0603
R5140	0613952H33	CER CHIP RES 22.0 OHM 5% 0603
R5144	0613952H81	CER CHIP RES 2200 OHM 5% 0603
R5145	0613952H51	CER CHIP RES 120 OHM 5% 0603
R5146	0613952H49	CER CHIP RES 100 OHM 5% 0603
R5147	0613952H45	CER CHIP RES 68.0 OHM 5% 0603
R5148	0613952H45	CER CHIP RES 68.0 OHM 5% 0603
R5149	0613952J25	CER CHIP RES 100K OHM 5% 0603
R5150	0613952H25	CER CHIP RES 10.0 OHM 5% 0603
R5151	0613952H25	CER CHIP RES 10.0 OHM 5% 0603
R5152	0613952H25	CER CHIP RES 10.0 OHM 5% 0603
R5153	0613952H25	CER CHIP RES 10.0 OHM 5% 0603
R5154	0613952H25	CER CHIP RES 10.0 OHM 5% 0603
R5155	0613952H25	CER CHIP RES 10.0 OHM 5% 0603
R5157	0613952J17	CER CHIP RES 47K OHM 5% 0603
R5158	0613952H59	CER CHIP RES 270 OHM 5% 0603
R5159	0613952G67	CER CHIP RES 0.0 +/-0.050 OHM
R5160	0613952H73	CER CHIP RES 1000 OHM 5% 0603
R5161	0613952H33	CER CHIP RES 22.0 OHM 5% 0603
R5162	0613952H33	CER CHIP RES 22.0 OHM 5% 0603
R5163	0613952H33	CER CHIP RES 22.0 OHM 5% 0603
R5164	NOTPLACED	GCAM DUMMY PART NUMBER
R5165	NOTPLACED	GCAM DUMMY PART NUMBER
R5166	0613952H25	CER CHIP RES 10.0 OHM 5% 0603
R5167	NOTPLACED	GCAM DUMMY PART NUMBER
R5168	NOTPLACED	GCAM DUMMY PART NUMBER
R5169	NOTPLACED	GCAM DUMMY PART NUMBER
R5170	0613952H25	CER CHIP RES 10.0 OHM 5% 0603
R5171	0613952H85	CER CHIP RES 3300 OHM 5% 0603
R5172	0613952H33	CER CHIP RES 22.0 OHM 5% 0603
R5176	0613952J13	CER CHIP RES 33K OHM 5% 0603
R5177	0613952H65	CER CHIP RES 470 OHM 5% 0603
R5178	0613952H25	CER CHIP RES 10.0 OHM 5% 0603
R5179	0613952H59	CER CHIP RES 270 OHM 5% 0603
R5180	0613952H85	CER CHIP RES 3300 OHM 5% 0603
R5181	0613952J19	CER CHIP RES 56K OHM 5% 0603
R5182	0613952G67	CER CHIP RES 0.0 +/-0.050 OHM
R5183	0613952H49	CER CHIP RES 100 OHM 5% 0603
R5184	0613952H75	CER CHIP RES 1200 OHM 5% 0603
R5185	0613952H33	CER CHIP RES 22.0 OHM 5% 0603

Reference	Motorola PN	Value
R5186	0613952J32	CER CHIP RES 200K OHM 5 0603
R5187	0613952H59	CER CHIP RES 270 OHM 5% 0603
R5188	NOTPLACED	GCAM DUMMY PART NUMBER
R5189	0613952G67	CER CHIP RES 0.0 +/-0.050 OHM
R5190	0613952J08	CER CHIP RES 20K OHM 5 0603
R5191	0613952J13	CER CHIP RES 33K OHM 5% 0603
R5192	0613952H93	CER CHIP RES 6800 OHM 5% 0603
R5193	0613952H49	CER CHIP RES 100 OHM 5% 0603
R5194	0613952H75	CER CHIP RES 1200 OHM 5% 0603
R5195	0613952H33	CER CHIP RES 22.0 OHM 5% 0603
R5196	0613952J32	CER CHIP RES 200K OHM 5 0603
R5197	0613952H59	CER CHIP RES 270 OHM 5% 0603
R5198	NOTPLACED	GCAM DUMMY PART NUMBER
R5199	0613952G67	CER CHIP RES 0.0 +/-0.050 OHM
R5204	0613952H84	CER CHIP RES 3000 OHM 5% 0603
R5205	0613952J03	CER CHIP RES 12K OHM 5% 0603
R5206	0613952H68	CER CHIP RES 620 OHM 5 0603
R5207	0613952H73	CER CHIP RES 1000 OHM 5% 0603
R5208	0613952H64	CER CHIP RES 430 OHM 5 0603
R5209	0613952H61	CER CHIP RES 330 OHM 5% 0603
R5210	0613952H37	CER CHIP RES 33.0 OHM 5% 0603
R5211	NOTPLACED	GCAM DUMMY PART NUMBER
R5212	NOTPLACED	GCAM DUMMY PART NUMBER
R5213	NOTPLACED	GCAM DUMMY PART NUMBER
R5214	NOTPLACED	GCAM DUMMY PART NUMBER
R5215	NOTPLACED	GCAM DUMMY PART NUMBER
R5216	NOTPLACED	GCAM DUMMY PART NUMBER
R5217	NOTPLACED	GCAM DUMMY PART NUMBER
R5218	0613952G67	CER CHIP RES 0.0 +/-0.050 OHM
R5219	NOTPLACED	GCAM DUMMY PART NUMBER
R5220	0613952G67	CER CHIP RES 0.0 +/-0.050 OHM
R5221	NOTPLACED	GCAM DUMMY PART NUMBER
R5222	0613952G67	CER CHIP RES 0.0 +/-0.050 OHM
R5301	0613952H63	CER CHIP RES 390 OHM 5% 0603
R5302	0613952Q61	CER CHIP RES 330 OHM 5% 0402
R5303	0613952Q81	CER CHIP RES 2200 OHM 5% 0402
R5304	0613952Q73	CER CHIP RES 1000 OHM 5 0402
R5311	0613952R66	CER CHIP RES 0.0 +/-0.050 OHM
R5312	0613952Q49	CER CHIP RES 100 OHM 5 0402
R5313	NOTPLACED	GCAM DUMMY PART NUMBER
R5314	0613952R13	CER CHIP RES 33K OHM 5% 0402
R5315	0613952Q53	CER CHIP RES 150 OHM 5% 0402
R5316	0613952Q53	CER CHIP RES 150 OHM 5% 0402
R5321	0613952H49	CER CHIP RES 100 OHM 5% 0603
R5322	0613952H49	CER CHIP RES 100 OHM 5% 0603
R5323	0613952H49	CER CHIP RES 100 OHM 5% 0603
R5324	0613952H49	CER CHIP RES 100 OHM 5% 0603

Reference	Motorola PN	Value
R5331	NOTPLACED	GCAM DUMMY PART NUMBER
R5332	NOTPLACED	GCAM DUMMY PART NUMBER
R5333	NOTPLACED	GCAM DUMMY PART NUMBER
R5334	0613952Q49	CER CHIP RES 100 OHM 5 0402
R5335	0613952R25	CER CHIP RES 100K OHM 5% 0402
R5336	0613952R05	CER CHIP RES 15K OHM 5% 0402
R5338	0613952R17	CER CHIP RES 47K OHM 5% 0402
R5351	0613952Q73	CER CHIP RES 1000 OHM 5 0402
R5352	0613952R17	CER CHIP RES 47K OHM 5% 0402
R5353	0613952Q49	CER CHIP RES 100 OHM 5 0402
R5354	0613952Q89	CER CHIP RES 4700 OHM 5 0402
R5355	0613952Q49	CER CHIP RES 100 OHM 5 0402
R5358	0613952R66	CER CHIP RES 0.0 +/-0.050 OHM
R5361	0613952R17	CER CHIP RES 47K OHM 5% 0402
R5362	0613952Q89	CER CHIP RES 4700 OHM 5 0402
R5363	0613952Q69	CER CHIP RES 680 OHM 5% 0402
R5364	0613952R66	CER CHIP RES 0.0 +/-0.050 OHM
R5365	0613952H64	CER CHIP RES 430 OHM 5 0603
R5366	0613952H64	CER CHIP RES 430 OHM 5 0603
R5370	0613952R37	CER CHIP RES 330K OHM 5% 0402
R5371	0613952Q81	CER CHIP RES 2200 OHM 5% 0402
R5401	0613952Q53	CER CHIP RES 150 OHM 5% 0402
R5402	0613952Q01	CER CHIP RES 1.0 OHM 5% 0402
R5403	0613952Q01	CER CHIP RES 1.0 OHM 5% 0402
R5404	0613952Q01	CER CHIP RES 1.0 OHM 5% 0402
R5405	0613952Q83	CER CHIP RES 2700 OHM 5% 0402
R5406	0613952H73	CER CHIP RES 1000 OHM 5% 0603
R5407	NOTPLACED	GCAM DUMMY PART NUMBER
R5408	0613959H74	CER CHIP RES 0.0 OHM JMP 1210
R5412	0613952Q49	CER CHIP RES 100 OHM 5 0402
R5413	0613952Q47	CER CHIP RES 82.0 OHM 5% 0402
R5414	0613952R66	CER CHIP RES 0.0 +/-0.050 OHM
R5415	0613952Q49	CER CHIP RES 100 OHM 5 0402
R5416	NOTPLACED	GCAM DUMMY PART NUMBER
R5417	0613959Y42	CER CHIP RES 51.0 OHM 5% 2512
R5418	0613952R66	CER CHIP RES 0.0 +/-0.050 OHM
R5419	0613952R66	CER CHIP RES 0.0 +/-0.050 OHM
R5420	0613952H73	CER CHIP RES 1000 OHM 5% 0603
R5421	0613952Q89	CER CHIP RES 4700 OHM 5 0402
R5422	0613952R01	CER CHIP RES 10K OHM 5% 0402
R5430	0613952Q49	CER CHIP RES 100 OHM 5 0402
R5431	0613952H83	CER CHIP RES 2700 OHM 5% 0603
R5451	0613952H53	CER CHIP RES 150 OHM 5% 0603
R5452	0613952H53	CER CHIP RES 150 OHM 5% 0603
R5453	0613952H53	CER CHIP RES 150 OHM 5% 0603
R5454	0613952H52	CER CHIP RES 130 OHM 5% 0603

Reference	Motorola PN	Value
R5455	0613952H45	CER CHIP RES 68.0 OHM 5% 0603
R5460	0613952R01	CER CHIP RES 10K OHM 5% 0402
R5461	NOTPLACED	GCAM DUMMY PART NUMBER
R5491	0613952R01	CER CHIP RES 10K OHM 5% 0402
R5501	0613952H73	CER CHIP RES 1000 OHM 5% 0603
R5503	0613952J13	CER CHIP RES 33K OHM 5% 0603
R5521	0613952R25	CER CHIP RES 100K OHM 5% 0402
R5522	0613952R12	CER CHIP RES 30K OHM 5% 0402
R5523	0613952Q81	CER CHIP RES 2200 OHM 5% 0402
R5524	0613952R01	CER CHIP RES 10K OHM 5% 0402
R5533	0613958H17	CER CHIP RES 4.7 OHM 5% 0805
R5541	0613952R25	CER CHIP RES 100K OHM 5% 0402
R5542	0613952R25	CER CHIP RES 100K OHM 5% 0402
R5543	0613952Q81	CER CHIP RES 2200 OHM 5% 0402
R5551	0613952R01	CER CHIP RES 10K OHM 5% 0402
R5552	0613952Q83	CER CHIP RES 2700 OHM 5% 0402
R5553	0613959Y51	CER CHIP RES OHM 5% 2512
R5554	0613958H69	CER CHIP RES 680 OHM 5% 0805
R5555	NOTPLACED	GCAM DUMMY PART NUMBER
R5601	0613952Q79	CER CHIP RES 1800 OHM 5% 0402
R5602	NOTPLACED	GCAM DUMMY PART NUMBER
R5603	NOTPLACED	GCAM DUMMY PART NUMBER
R5604	0613952Q80	CER CHIP RES 2000 OHM 5% 0402
R5605	0613952Q37	CER CHIP RES 33.0 OHM 5% 0402
R5607	0613952Q37	CER CHIP RES 33.0 OHM 5% 0402
R5608	0613952Q59	CER CHIP RES 270 OHM 5 0402
R5609	0613952Q57	CER CHIP RES 220 OHM 5% 0402
R5621	0613952R03	CER CHIP RES 12K OHM 5% 0402
R5622	0613952Q83	CER CHIP RES 2700 OHM 5% 0402
R5623	0613952Q68	CER CHIP RES 620 OHM 5% 0402
R5624	0613952Q53	CER CHIP RES 150 OHM 5% 0402
R5625	0613952R66	CER CHIP RES 0.0 +/-0.050 OHM
R5628	0613952R66	CER CHIP RES 0.0 +/-0.050 OHM
R5629	0613952R66	CER CHIP RES 0.0 +/-0.050 OHM
R5630	NOTPLACED	GCAM DUMMY PART NUMBER
R5631	0613952Q53	CER CHIP RES 150 OHM 5% 0402
R5632	0613952R09	CER CHIP RES 22K OHM 5% 0402
R5634	0613952Q25	CER CHIP RES 10.0 OHM 5% 0402
R5636	0613952Q33	CER CHIP RES 22.0 OHM 5% 0402
R5637	NOTPLACED	GCAM DUMMY PART NUMBER
R5651	0613952R05	CER CHIP RES 15K OHM 5% 0402
R5652	0613952Q49	CER CHIP RES 100 OHM 5 0402
R5653	0613952R66	CER CHIP RES 0.0 +/-0.050 OHM
R5654	0613952Q73	CER CHIP RES 1000 OHM 5 0402
R5655	0613952Q73	CER CHIP RES 1000 OHM 5 0402

Reference	Motorola PN	Value
R5668	0613952R25	CER CHIP RES 100K OHM 5% 0402
R5669	0613952Q73	CER CHIP RES 1000 OHM 5 0402
R5670	0613952Q73	CER CHIP RES 1000 OHM 5 0402
R5671	0613952Q65	CER CHIP RES 470 OHM 5% 0402
R5672	0613952R08	CER CHIP RES 20K OHM 5 0402
R5681	0613952Q65	CER CHIP RES 470 OHM 5% 0402
R5702	0613952R01	CER CHIP RES 10K OHM 5% 0402
R5703	0613952Q83	CER CHIP RES 2700 OHM 5% 0402
R5704	0613952Q59	CER CHIP RES 270 OHM 5 0402
R5705	0613952Q46	CER CHIP RES 75.0 OHM 5 0402
R5707	NOTPLACED	GCAM DUMMY PART NUMBER
R5709	0613952R66	CER CHIP RES 0.0 +/-0.050 OHM
R5710	NOTPLACED	GCAM DUMMY PART NUMBER
R5711	0613952Q71	CER CHIP RES 820 OHM 5% 0402
R5712	0613952Q25	CER CHIP RES 10.0 OHM 5% 0402
R5713	0613952Q75	CER CHIP RES 1200 OHM 5 0402
R5714	0613952Q49	CER CHIP RES 100 OHM 5 0402
R5715	0613952R66	CER CHIP RES 0.0 +/-0.050 OHM
R5721	NOTPLACED	GCAM DUMMY PART NUMBER
R5722	0613952Q77	CER CHIP RES 1500 OHM 5% 0402
R5723	0613952R01	CER CHIP RES 10K OHM 5% 0402
R5725	0613952Q79	CER CHIP RES 1800 OHM 5% 0402
R5726	0613952Q57	CER CHIP RES 220 OHM 5% 0402
R5727	0613952Q80	CER CHIP RES 2000 OHM 5% 0402
R5728	NOTPLACED	GCAM DUMMY PART NUMBER
R5731	0613952Q37	CER CHIP RES 33.0 OHM 5% 0402
R5732	0613952Q49	CER CHIP RES 100 OHM 5 0402
R5733	0613952Q59	CER CHIP RES 270 OHM 5 0402
R5734	0613952Q37	CER CHIP RES 33.0 OHM 5% 0402
R5803	0613952H35	CER CHIP RES 27.0 OHM 5 0603
R5804	0613952H47	CER CHIP RES 82.0 OHM 5 0603
R5805	0613952H47	CER CHIP RES 82.0 OHM 5 0603
R5806	0613952H81	CER CHIP RES 2200 OHM 5% 0603
R5807	0613952H57	CER CHIP RES 220 OHM 5% 0603
R5808	0613952H57	CER CHIP RES 220 OHM 5% 0603
R5809	0613952G67	CER CHIP RES 0.0 +/-0.050 OHM
R5810	NOTPLACED	GCAM DUMMY PART NUMBER
R5814	NOTPLACED	GCAM DUMMY PART NUMBER
R5816	0613952H69	CER CHIP RES 680 OHM 5 0603
R5819	0613952H47	CER CHIP RES 82.0 OHM 5 0603
R5837	0613952H69	CER CHIP RES 680 OHM 5 0603
R5840	0613952H89	CER CHIP RES 4700 OHM 5% 0603
R5841	0613952G67	CER CHIP RES 0.0 +/-0.050 OHM
R5842	0613952G67	CER CHIP RES 0.0 +/-0.050 OHM
R5843	0613952G67	CER CHIP RES 0.0 +/-0.050 OHM
R5844	0613952G67	CER CHIP RES 0.0 +/-0.050 OHM

Reference	Motorola PN	Value
R5845	0613952H83	CER CHIP RES 2700 OHM 5% 0603
R5846	0613952H89	CER CHIP RES 4700 OHM 5% 0603
R5847	0613952J22	CER CHIP RES 75K OHM 5 0603
R5849	NOTPLACED	GCAM DUMMY PART NUMBER
R5850	0613952Q49	CER CHIP RES 100 OHM 5 0402
R5851	0613952Q49	CER CHIP RES 100 OHM 5 0402
R5852	0613952Q49	CER CHIP RES 100 OHM 5 0402
R5853	0613952Q49	CER CHIP RES 100 OHM 5 0402
R5854	0613952Q49	CER CHIP RES 100 OHM 5 0402
R5855	0613952R01	CER CHIP RES 10K OHM 5% 0402
R5856	0613952R01	CER CHIP RES 10K OHM 5% 0402
R5857	0613952R01	CER CHIP RES 10K OHM 5% 0402
R5858	0613952R01	CER CHIP RES 10K OHM 5% 0402
R5859	NOTPLACED	GCAM DUMMY PART NUMBER
R5860	0613952H57	CER CHIP RES 220 OHM 5% 0603
R5861	0613952G67	CER CHIP RES 0.0 +/-0.050 OHM
R5862	NOTPLACED	GCAM DUMMY PART NUMBER
R5863	0613952G67	CER CHIP RES 0.0 +/-0.050 OHM
RT5551	NOTPLACED	GCAM DUMMY PART NUMBER
SH5601	2666500A03	SHIELD VCO
SH5602	2666500A03	SHIELD VCO
SH5701	2666500A03	SHIELD VCO
SH5702	2666500A03	SHIELD VCO
T5801	2580443L23	XFMR,BALUN,,,SM
T5802	2580443L20	XFMR,BALUN
U0100	5166537A01	TIMER,RTC,DS1306,SM,TSSOP20, ..
U0102	5114006A02	PB-FREE, NOTCOMPLETELYENRICHED
U0103	5114006A02	PB-FREE, NOTCOMPLETELYENRICHED
U0104	5188691V01	IC,ANLG SW,,NC7SB3157P6X,SM,SC
U0150	5185765B26	IC PWR CTRL IN MOS20
U0201	5114002A17	IC,MUX/DEMUX,SM,SOIC16,3PER PK
U0202	5166544A01	IC CMOS BILATERAL SW
U0203	5166542A01	IC NONVOLATILE DIGITAL POTENTI
U0204	5166542A01	IC NONVOLATILE DIGITAL POTENTI
U0205	5102463J95	AUDIO PA TDA1519C
U0206	5114016A18	IC,OP AMP,4PER PKG,GP,SOIC,,PB
U0207	5189378V12	IC,EEPROM,128K,16K X 8,BGA,AT2
U0300	5164015H94	IC, LM2941, TO DROPOUT REG
U0301	5164015H94	IC, LM2941, TO DROPOUT REG
U0302	5164015H94	IC, LM2941, TO DROPOUT REG
U0303	5114014A07	IC,STANDARD POS,,,DPAK,1 PER P

Reference	Motorola PN	Value
U0304	5114014A22	IC,LINEAR VOLTAGE REGULATOR,FX
U0305	5114014M39	IC,LINEAR VOLTAGE REGULATOR,FX
U0306	5114014A22	IC,LINEAR VOLTAGE REGULATOR,FX
U0307	5166534A01	LINEAR VOLTAGE REGULATOR,LOW D
U0308	5114004A35	IC VOLTAGE DETECTOR 2.8V
U0401	5114000B39	IC,BFR,1PER PKG,SM,SOT-353,PB-
U0402	5114000B39	IC,BFR,1PER PKG,SM,SOT-353,PB-
U0403	5114000B39	IC,BFR,1PER PKG,SM,SOT-353,PB-
U0404	5114000B39	IC,BFR,1PER PKG,SM,SOT-353,PB-
U0405	5187970L15	IC USB TRANS FULL-SPEED
U0406	5114006A02	PB-FREE, NOTCOMPLETELYENRICHED
U0407	NOTPLACED	GCAM DUMMY PART NUMBER
U0408	5114019M13	IC BUFFER OCT 3-ST NON-INV
U0410	NOTPLACED	GCAM DUMMY PART NUMBER
U1100	5166541A01	IC,,BGA,BGA,DSP56XXX,52MHZ,16
U1101	NOTPLACED	GCAM DUMMY PART NUMBER
U1102	5,19E+49	IC,FLSH,,128MB,8M X 16,60,SM,B
U1103	5185941F11	IC,SRAM,32MB,2MX16,PB-FR,70NS,
U1104	5114000B39	IC,BFR,1PER PKG,SM,SOT-353,PB-
U1105	5109512F66	IC,VREG,LP2985IM5X-1.8,SM,SOT-
U5001	5115019H01	3.3V REGULATOR IN SOT23-5 PKG
U5002	5116959H01	MMIC MIXER WITH IF BUFFER
U5003	5164852H27	IC, HIGH-LINEARITY LNA
U5101	5185963A85	IC-ABACUS III-LP
U5102	5115019H01	3.3V REGULATOR IN SOT23-5 PKG
U5103	5115019H01	3.3V REGULATOR IN SOT23-5 PKG
U5104	5114000B39	IC,BFR,1PER PKG,SM,SOT-353,PB-
U5105	5114000B39	IC,BFR,1PER PKG,SM,SOT-353,PB-
U5201	9166513A01	73.35MHZ CRYSTAL FILTER
U5321	5115019H01	3.3V REGULATOR IN SOT23-5 PKG
U5322	5115026H01	IC,LOW DROPOUT,,SM,SOT-23/6,,
U5331	5185177Y01	IC TESTED AT25016 48 PIN W18
U5401	5115678H01	VHF/UHF/800/900 MHZ LDMOS DRIV
U5501	5115022H01	IC,TEMP SENS,LM50C,SM,SOT-23
U5701	5105750U56	IC PKG DIE VCO BUFFER
U5702	5185368C18	ESCORT IC IN 16 PIN QFN PACKAG

Reference	Motorola PN	Value
U5704	2113946K02	CAP CER CHP 0.10UF 16V
U5808	NOTPLACED	GCAM DUMMY PART NUMBER
U5809	5186988J77	IC,XMTR,,SM,BGA,,JAVELIN EPP
U5810	5166554A01	ADDAG IC (CMOS), 49 BGA@0.8MM
VR0163	4813977M11	DIODE,ZEN,MBZ5232,SM,SOT-23,5.
VR0300	4813979C17	DIODE,SUPR,,SM,,32V,,AVALANC
VR0301	4813977M19	DIODE,ZEN,MBZ5240,SM,SOT-23,10
VR0302	NOTPLACED	GCAM DUMMY PART NUMBER
VR0325	4813977M10	DIODE,ZEN,,TO-236,5.1V,,225
VR0401	4813979C11	DIODE,SUPR,SOT-26/SC-74,15V,.2
VR0402	4813979C11	DIODE,SUPR,SOT-26/SC-74,15V,.2
VR0403	4813979C11	DIODE,SUPR,SOT-26/SC-74,15V,.2
VR0405	4813979P10	DIODE ARRAY,TRANSIENT PROTECTI
VR0406	4813977M36	DIODE,ZEN,MBZ5257,SM,SOT-23,33
VR0407	4813977M36	DIODE,ZEN,MBZ5257,SM,SOT-23,33
VR5401	4813977M11	DIODE,ZEN,MBZ5232,SM,SOT-23,5.
W5601	4802245J57	COAXIAL CERAMIC INDUCTOR SMD
W5701	4802245J57	COAXIAL CERAMIC INDUCTOR SMD
Y0101	4809995L05	XTAL QUARTZ 32.768KHZ CC4V-T1
Y5362	5102463J88	REF OSC, 16.8 MHz, 0.8PPM, SMD

Note: For optimum performance, diodes, transistors and integrated circuits must be ordered by MOTOROLA part numbers.

Parts on the GPS Board (0166502N65)

Reference	Motorola PN	Value
C1	2113944A28	CAP CER CHP 18.0PF 50V 5%
C10	2113944A28	CAP CER CHP 18.0PF 50V 5%
C11	2113741F25	CAP CHIP CL2 X7R REEL 1000
C12	2113944A28	CAP CER CHP 18.0PF 50V 5%
C14	2113945D04	CAP CER CHP 100,000PF 25V 10%
C15	2113944A28	CAP CER CHP 18.0PF 50V 5%
C16	2113741F25	CAP CHIP CL2 X7R REEL 1000
C17	2113944C48	CAP CER CHP 560.OPF 50V 5%
C18	2113944C55	CAP CER CHP 2200.OPF 50V 5%
C19	2113944C47	CAP CER CHP 150.0PF 50V 5%
C2	2113945D04	CAP CER CHP 100,000PF 25V 10%
C20	2113944C06	CAP CER CHP 470.0PF 50V 5%
C21	2113944C45	CAP CER CHP 100.0PF 50V 5%
C22	2113945D04	CAP CER CHP 100,000PF 25V 10%
C23	2313960F04	CAP TANT 33 UF 10% 16V 6032-28
C24	2113944C47	CAP CER CHP 150.0PF 50V 5%
C25	2113945D04	CAP CER CHP 100,000PF 25V 10%
C26	2313960D07	CAP TANT 10 UF 10% 16V 3528-21
C27	2313960F04	CAP TANT 33 UF 10% 16V 6032-28
C28	2113944C45	CAP CER CHP 100.0PF 50V 5%
C29	2113945D04	CAP CER CHP 100,000PF 25V 10%
C3	2113946F05	CAP,CHIP,10UF,,+10%,-10%,6.3V-DC,08
C30	2313960F04	CAP TANT 33 UF 10% 16V 6032-28
C31	2113944C47	CAP CER CHP 150.0PF 50V 5%
C32	2313960D07	CAP TANT 10 UF 10% 16V 3528-21
C33	2113944C45	CAP CER CHP 100.0PF 50V 5%
C37	2113945D04	CAP CER CHP 100,000PF 25V 10%
C38	2113944A28	CAP CER CHP 18.0PF 50V 5%
C39	2113944A33	CAP CER CHP 47.0PF 50V 5%
C4	2113946F05	CAP,CHIP,10UF,,+10%,-10%,6.3V-DC,08
C40	2113945D04	CAP CER CHP 100,000PF 25V 10%
C41	2113944A33	CAP CER CHP 47.0PF 50V 5%
C42	2113944A05	CAP CER CHP 1.5PF 50V 0.25PF
C43	2113944A28	CAP CER CHP 18.0PF 50V 5%
C5	2113946F05	CAP,CHIP,10UF,,+10%,-10%,6.3V-DC,08
C6	2113944A28	CAP CER CHP 18.0PF 50V 5%
C7	2113944A28	CAP CER CHP 18.0PF 50V 5%
C8	2113944A28	CAP CER CHP 18.0PF 50V 5%
D1	4813978C02	PB FREE, NOT COMPLETELY ENRICHED
E1	7686949J08	FERRITE BEAD CHIP-0603 SIZE
E2	7686949J08	FERRITE BEAD CHIP-0603 SIZE
E3	7686949J08	FERRITE BEAD CHIP-0603 SIZE
FL1	9180310L38	PASSIVE FILTER,SAW,BAND-

Reference	Motorola PN	Value
FL2	9180310L39	PASSIVE FIL-TER,SAW,,1.57542GHZNOM,1
J1	0986197B01	CONN ZIF HOR 24 PIN BOT CONT
J2	NOTPLACED	GCAM DUMMY PART NUMBER
L1	2414015B16	IDCTR,CHIP,27NH,2%,500MA,.25O HM,CER
L11	2414017P12	IND CER CHIP 8.2 NH 5%
L12	2414017P09	IND CER CHIP 4.7 NH +/-0.3NH
L3	2414015B16	IDCTR,CHIP,27NH,2%,500MA,.25O HM,CER
L4	2414015B16	IDCTR,CHIP,27NH,2%,500MA,.25O HM,CER
L5	2414017P17	IND CER CHIP 22.0 NH 5%
L6	2414015B16	IDCTR,CHIP,27NH,2%,500MA,.25O HM,CER
R10	0613952H80	CER CHIP RES 2000 OHM 5% 0603
R12	0613959Y32	CER CHIP RES 20.0 OHM 5% 2512
R14	0613958D51	CER CHIP RES 3320 OHM 1% 0805
R15	0613952J86	RES,MF,33KOHM,1%,.1W,SM,0603,200PPM
R16	NOTPLACED	GCAM DUMMY PART NUMBER
R17	0613952G67	CER CHIP RES 0.0 +/-0.050 OHM
R18	NOTPLACED	GCAM DUMMY PART NUMBER
R19	0613952E69	CER CHIP RES 51.1K OHM 1% 0603
R20	0613958D01	CER CHIP RES 1000 OHM 1% 0805
R21	0613952E85	CER CHIP RES 75.0K OHM 1% 0603
R22	NOTPLACED	GCAM DUMMY PART NUMBER
R23	0613952G67	CER CHIP RES 0.0 +/-0.050 OHM
R24	NOTPLACED	GCAM DUMMY PART NUMBER
R25	0613952E69	CER CHIP RES 51.1K OHM 1% 0603
R26	0613952J25	CER CHIP RES 100K OHM 5% 0603
R27	0613958D51	CER CHIP RES 3320 OHM 1% 0805
R28	0613952J25	CER CHIP RES 100K OHM 5% 0603
R29	0613952Q70	CER CHIP RES 750 OHM 5% 0402
R30	0613952G67	CER CHIP RES 0.0 +/-0.050 OHM
R5	0613952J01	CER CHIP RES 10K OHM 5% 0603
U1	5164015H94	IC, LM2941, TO DROPOUT REG
U2	5104187K94	IC LP2986ILDY-3.3 VLTG REG
U3	5104187K94	IC LP2986ILDY-3.3 VLTG REG
U4	5109841C71	IC,MICROP,,SM,,FEATURES MEMORY &
U5	5164015H55	IC,RF AMPLI-FIER,,UPC8211TK,SM,,18.
U6	5114000B39	IC 1 GATE 2-INPUT NOR
VR1	4813977C23	DIODE 13V 'H3' MMSZ5243BT1
Y1	4809718L20	OSC,TCXO,26MHZ,SM,,MDL 3.2X2.5X1

Reference	Motorola PN	Value
	3066540B01	CBL, ASSY, RF, 53MMDIA, 1COND, DOUBLE S
	8466576A01	PCB,DAUGHTER, GPS SUBMODUL
	3066541B01	CBL,FLT,.3MMDIA,24COND,UNSHLD,80MML

Note: For optimum performance, diodes, transistors and integrated circuits must be ordered by MOTOROLA part numbers.

CHAPTER 8.2

CONTROL HEADS: SCHEMATICS, PCBs and PARTS LISTS

Enhanced Control Head
Expansion Head
Remote Mount Head
Motorcycle Control Head

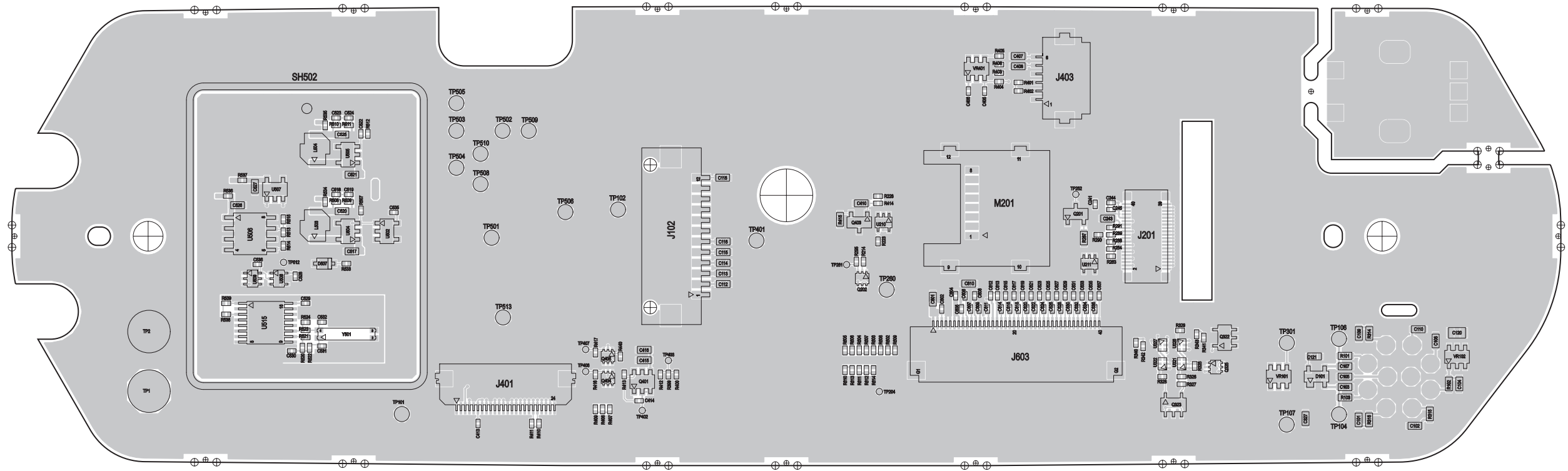
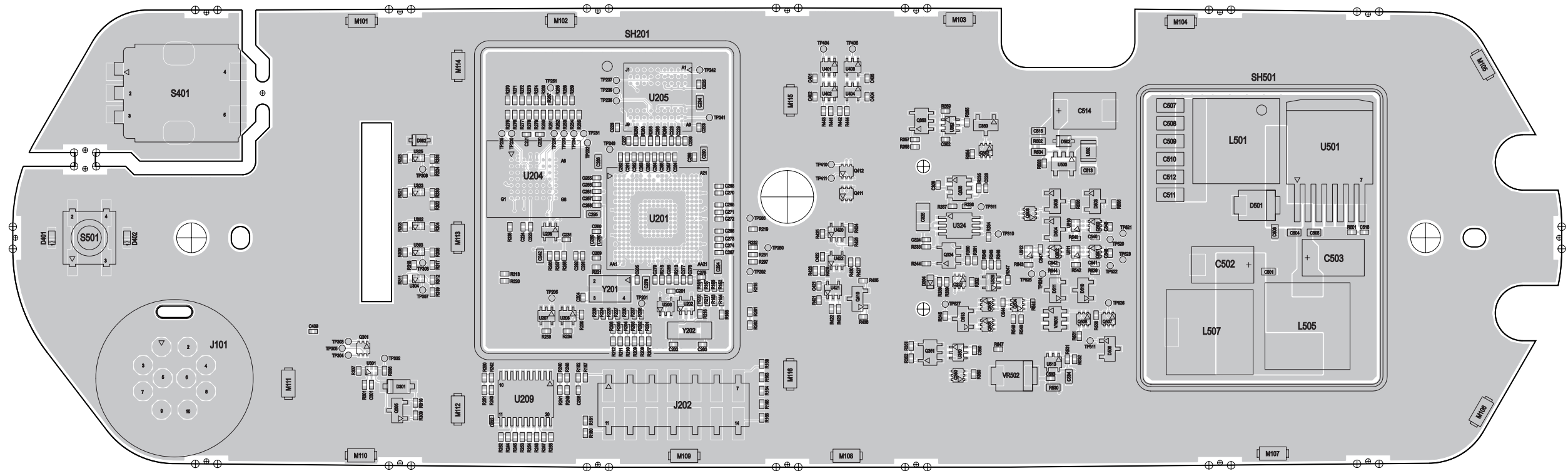

PCB / ENHANCED_CONTROL_HEAD / BOTTOM & TOP SIDE (PCB: 8466586A01_A)

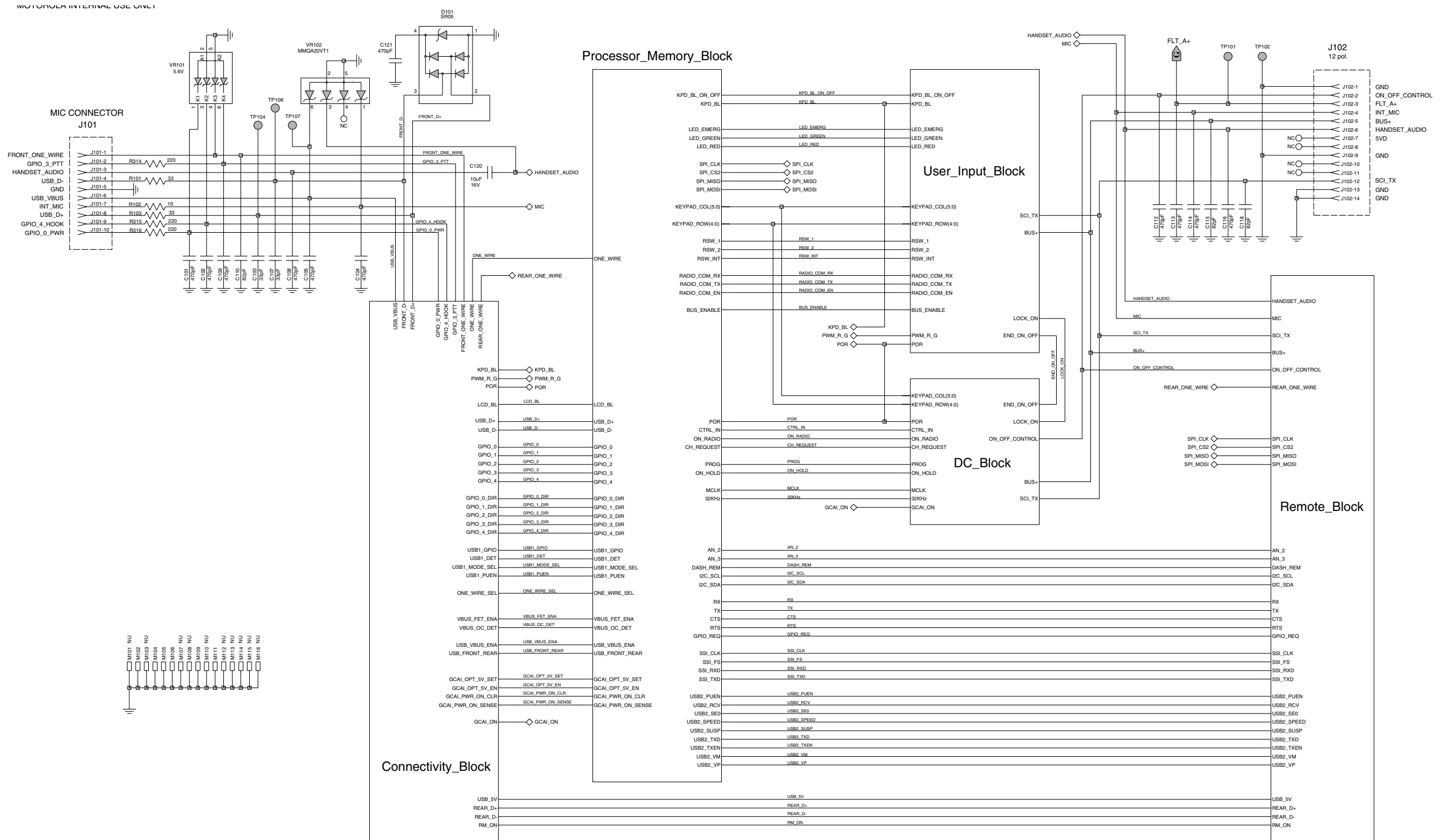

ENHANCED_CONTROL_HEAD / Schematic sheet 1 (PCB: 8466586A01_A)

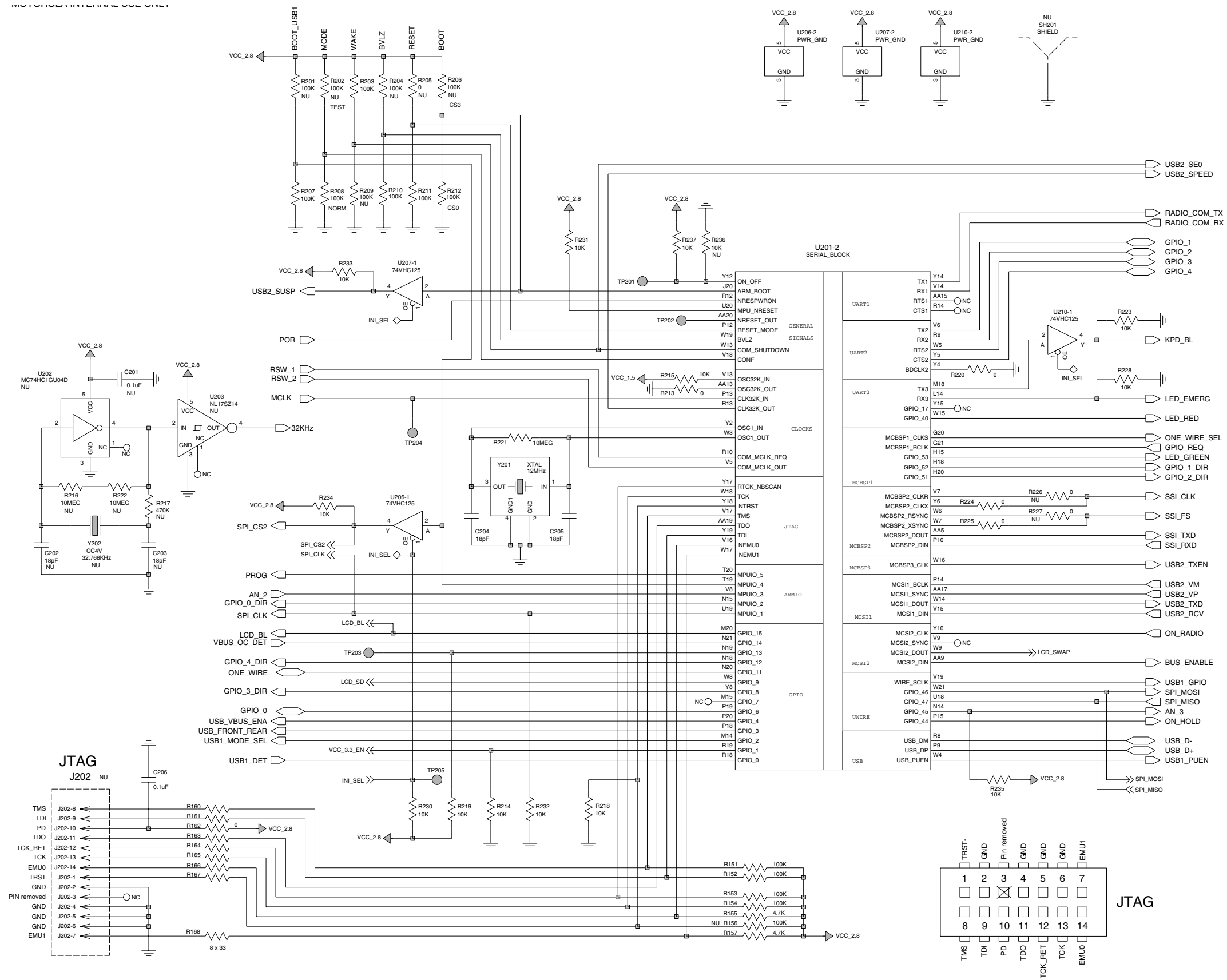

ENHANCED_CONTROL_HEAD / Schematic sheet 2 (PCB: 8466586A01_A)

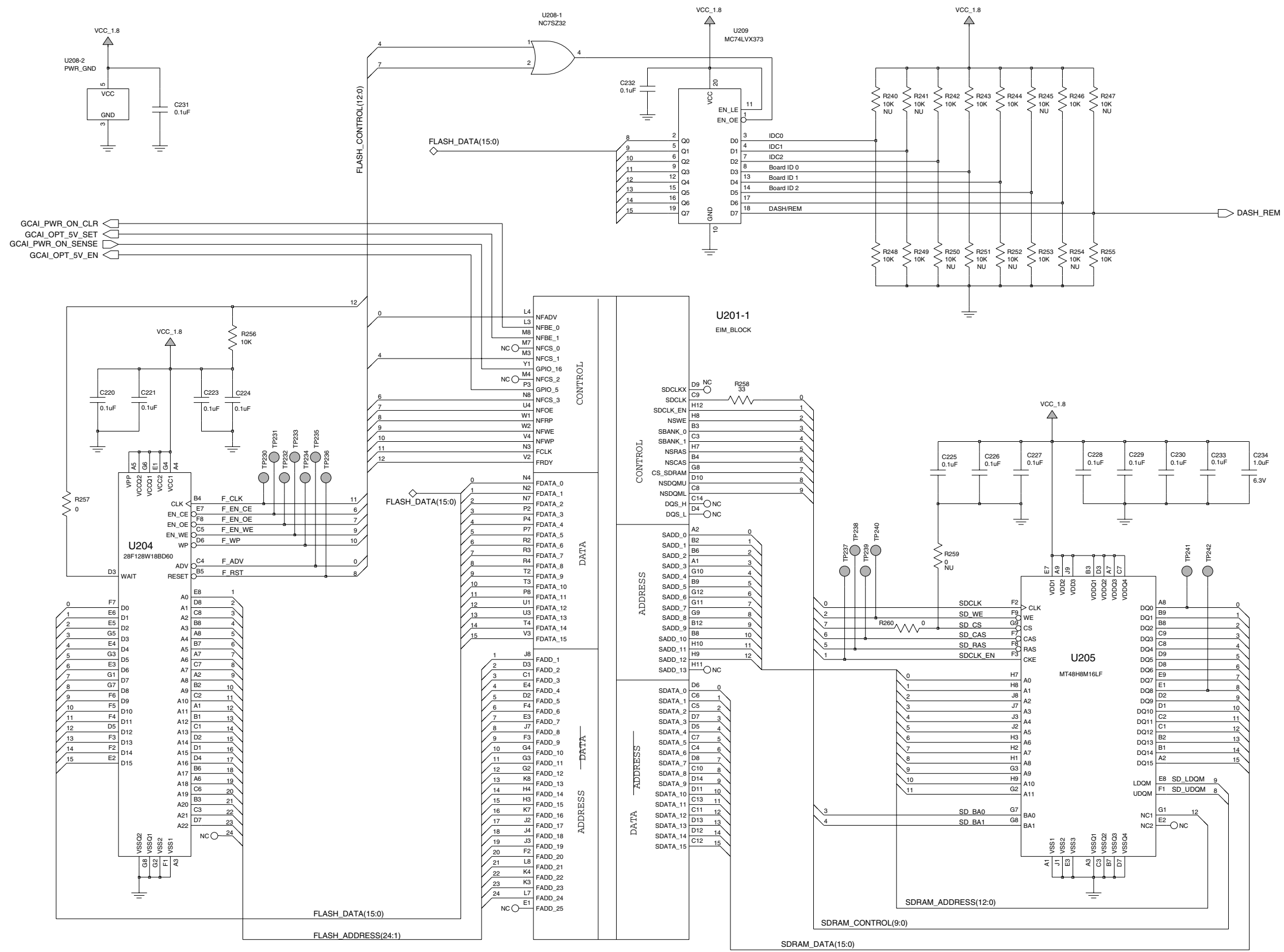

ENHANCED_CONTROL_HEAD / Schematic sheet 3 (PCB: 8466586A01_A)

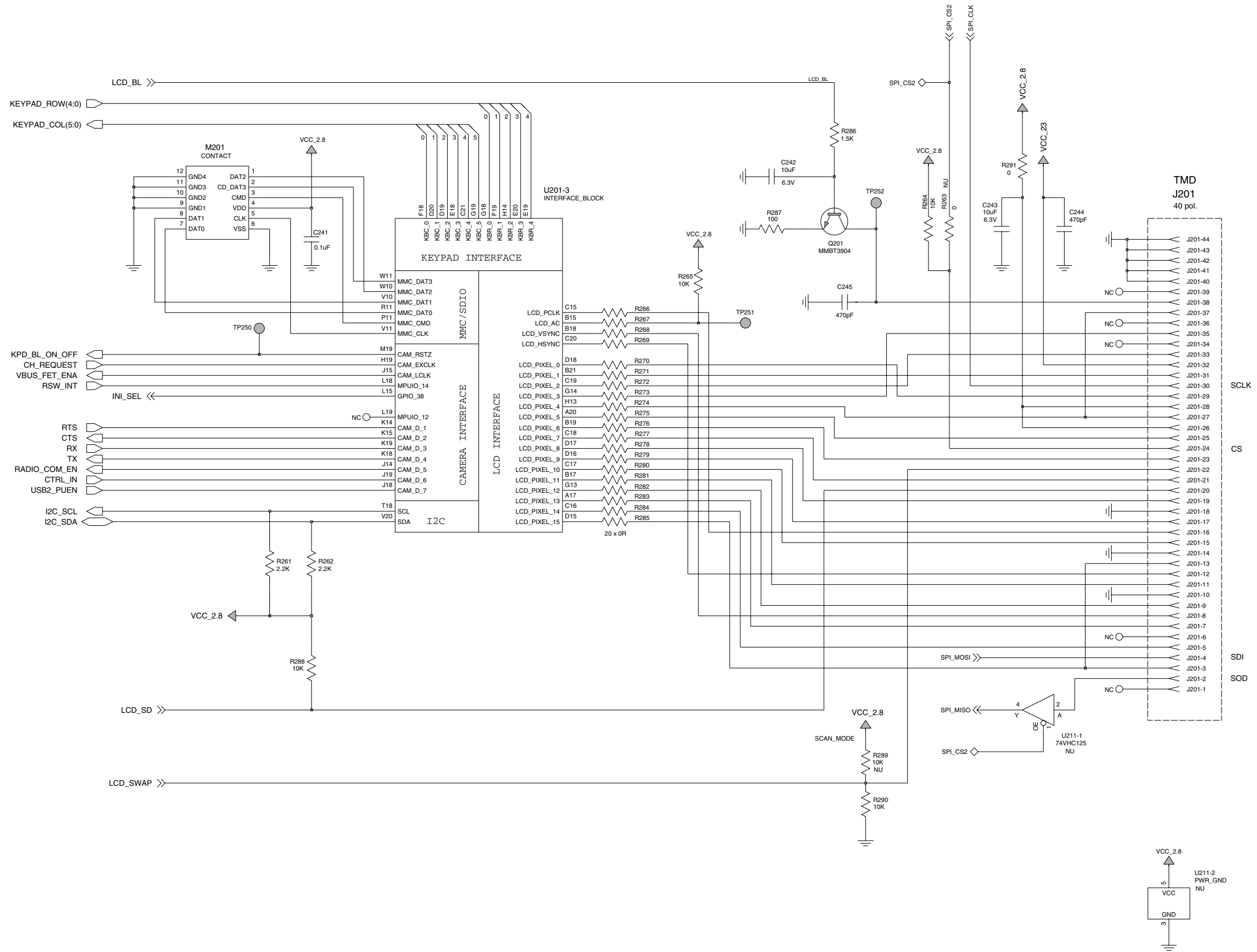

ENHANCED_CONTROL_HEAD / Schematic sheet 4 (PCB: 8466586A01_A)

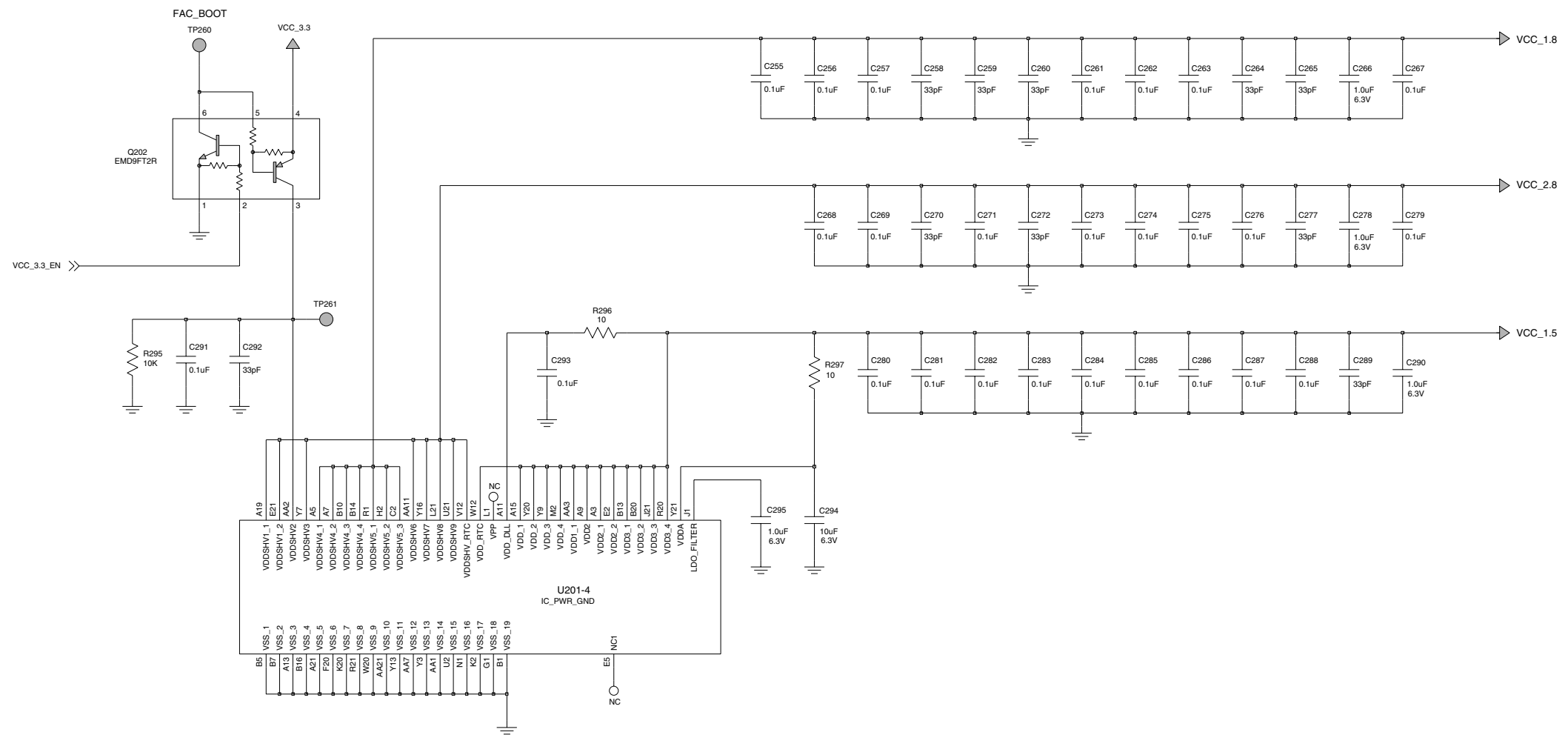

ENHANCED_CONTROL_HEAD / Schematic sheet 5 (PCB: 8466586A01_A)

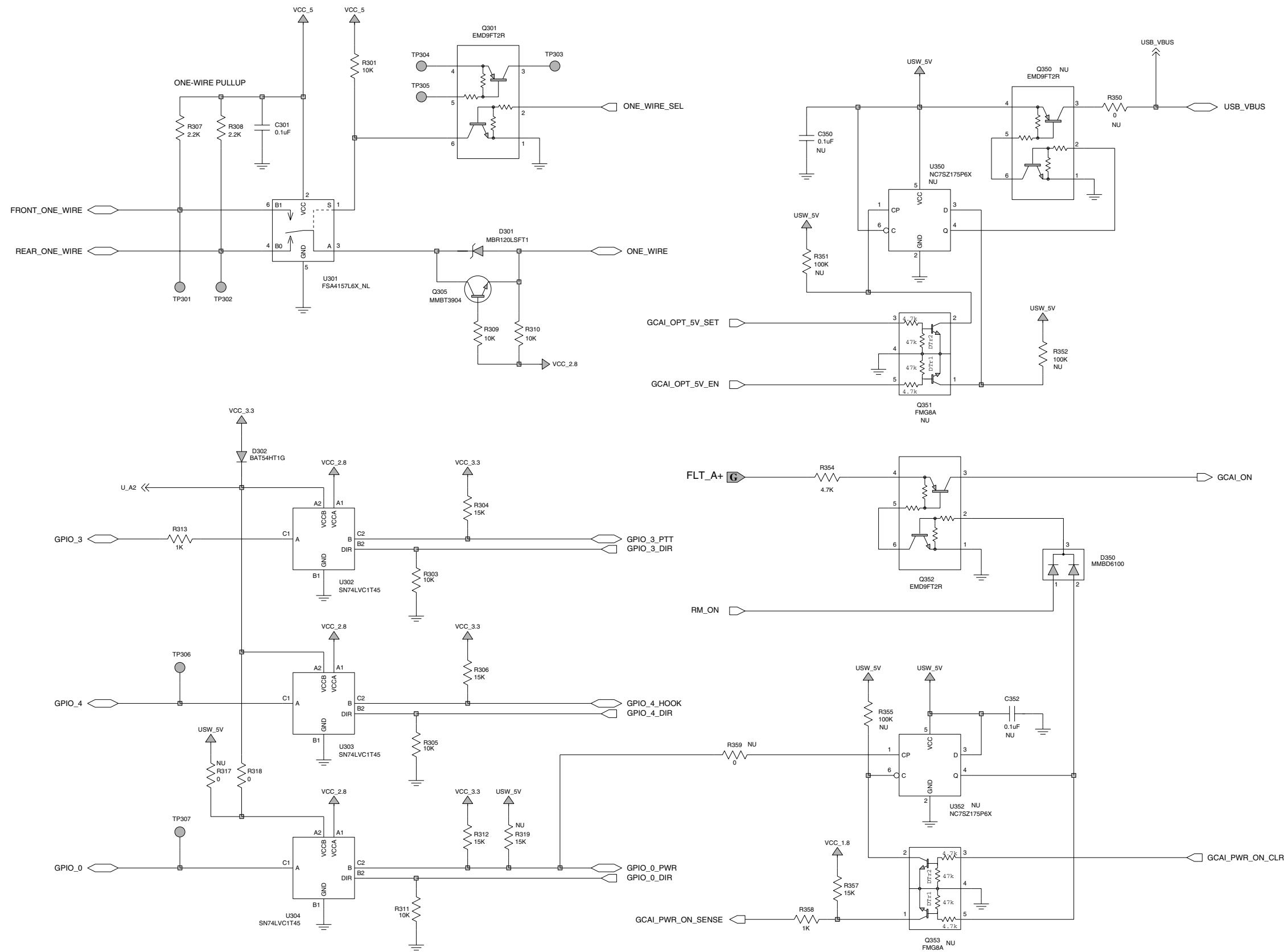

ENHANCED_CONTROL_HEAD / Schematic sheet 6 (PCB: 8466586A01_A)

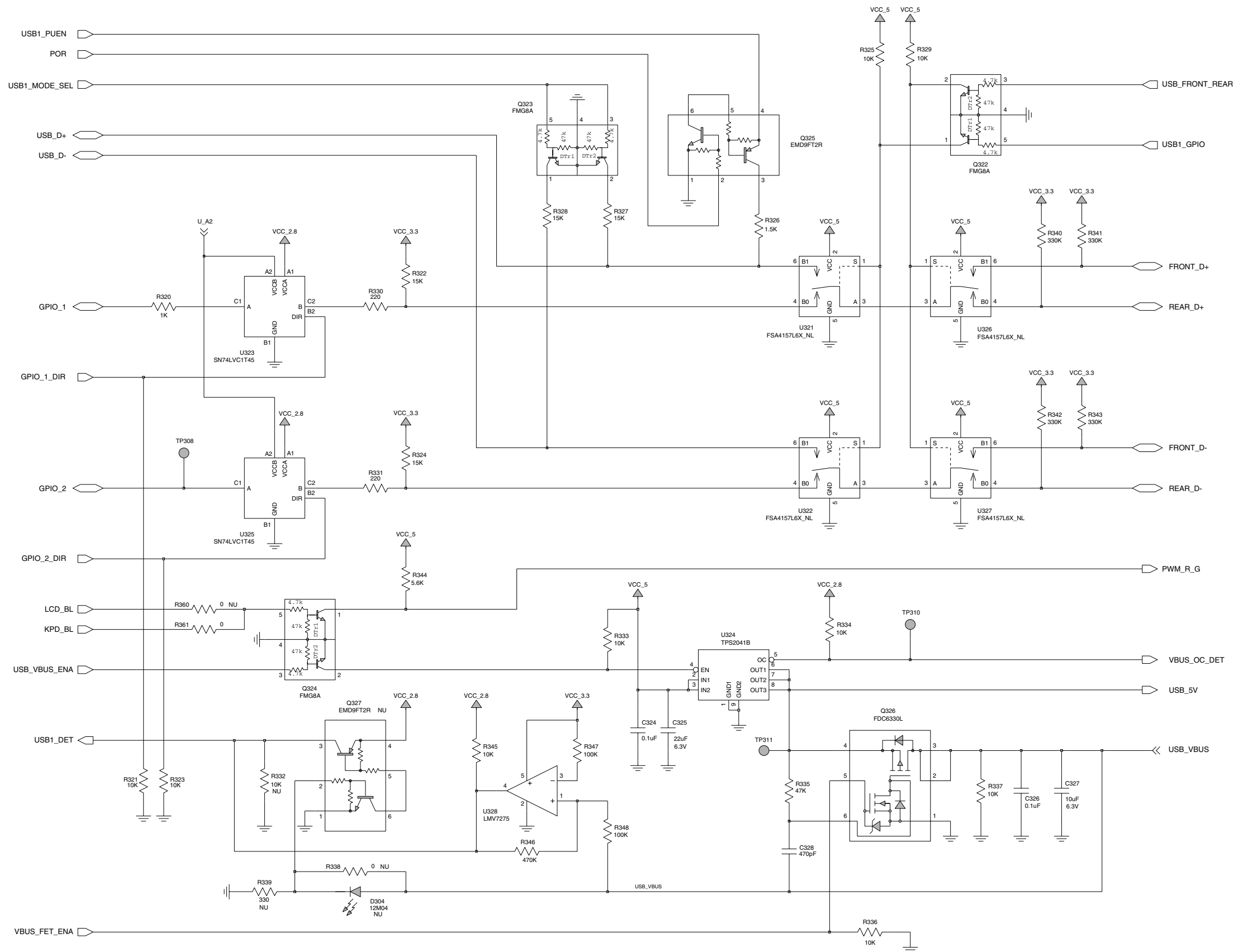

ENHANCED_CONTROL_HEAD / Schematic sheet 7 (PCB: 8466586A01_A)

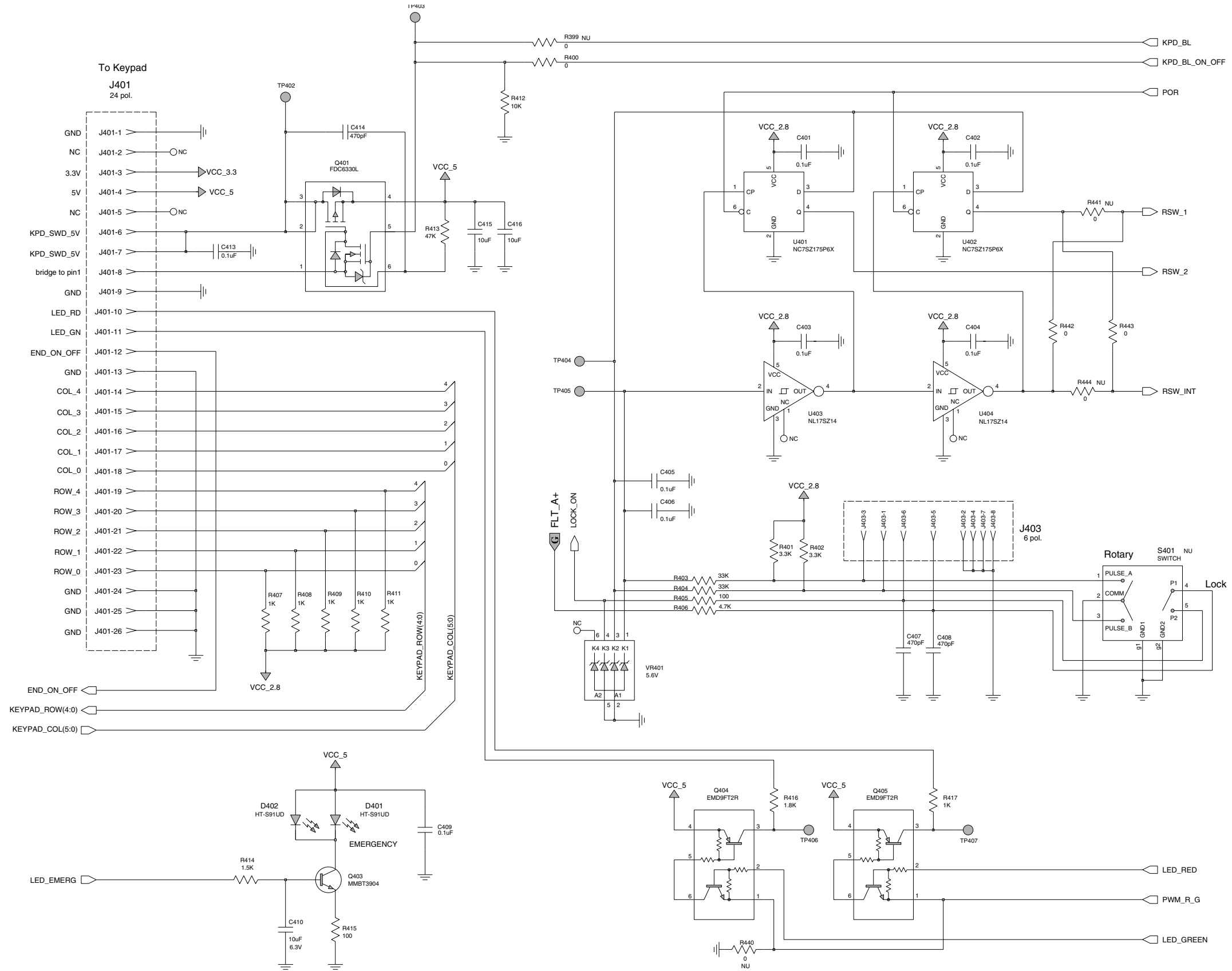

ENHANCED_CONTROL_HEAD / Schematic sheet 8 (PCB: 8466586A01_A)

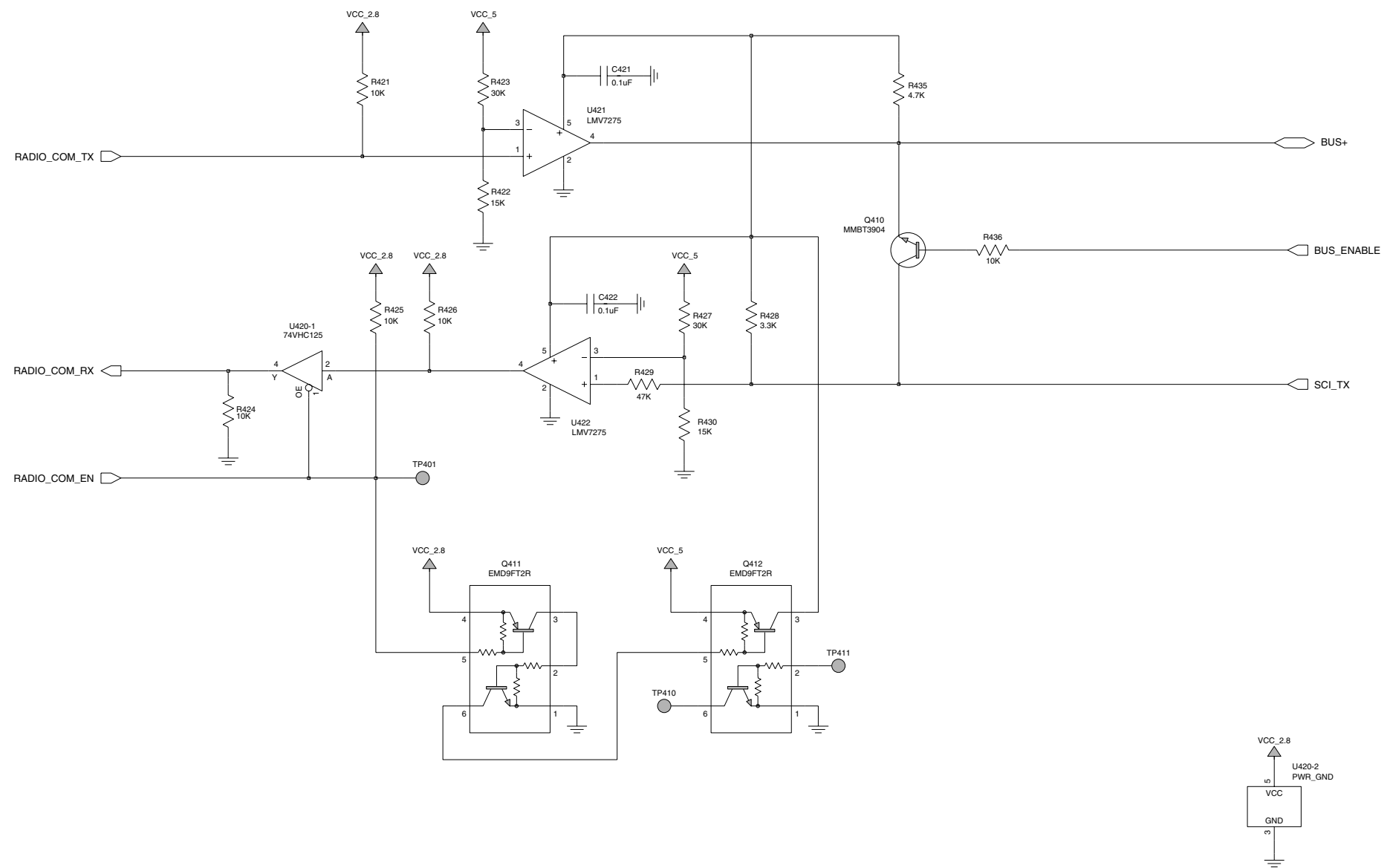

ENHANCED_CONTROL_HEAD / Schematic sheet 9 (PCB: 8466586A01_A)

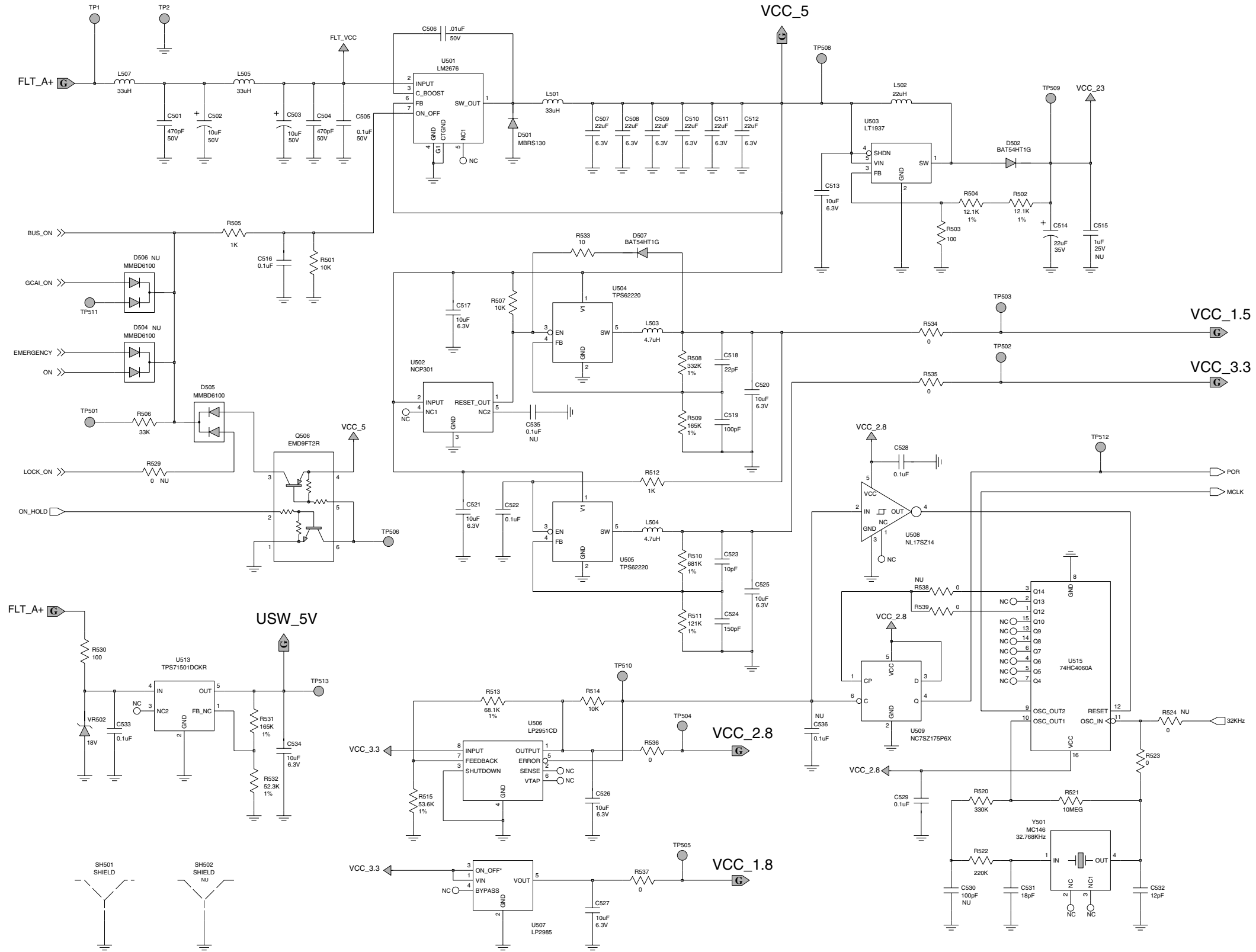

ENHANCED_CONTROL_HEAD / Schematic sheet 10 (PCB: 8466586A01_A)

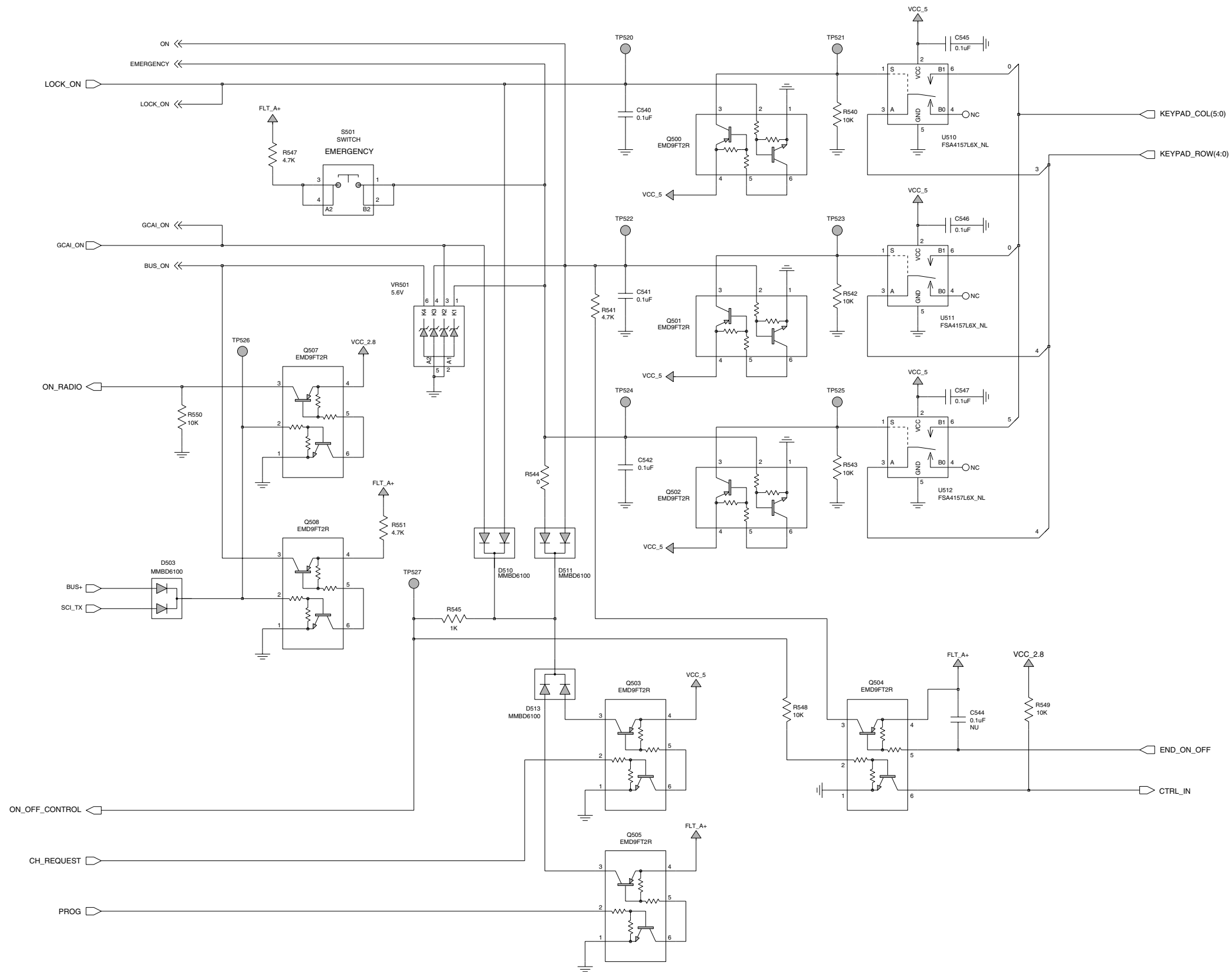

ENHANCED_CONTROL_HEAD / Schematic sheet 11 (PCB: 8466586A01_A)

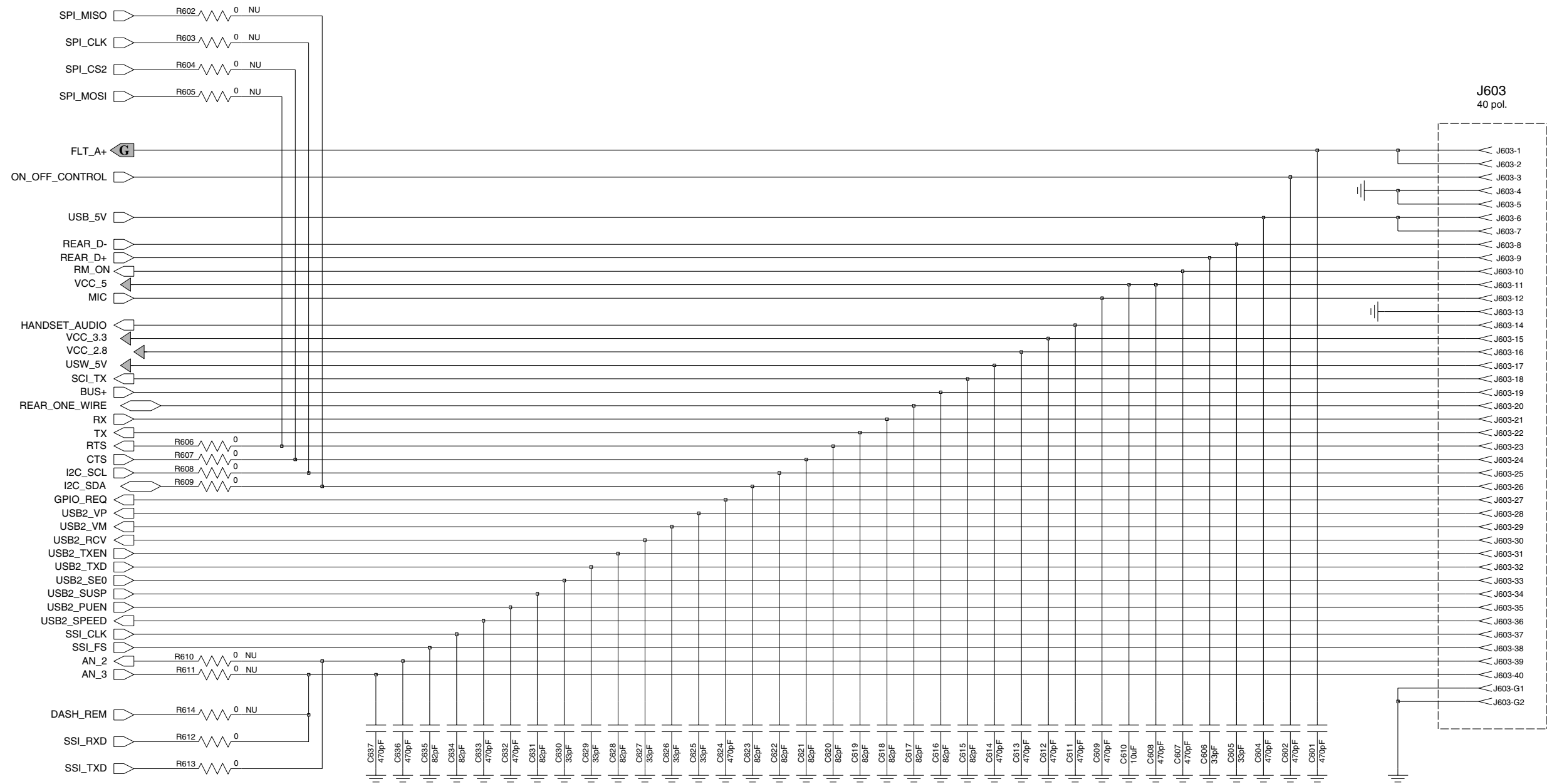

ENHANCED_CONTROL_HEAD / Schematic sheet 12 (PCB: 8466586A01_A)

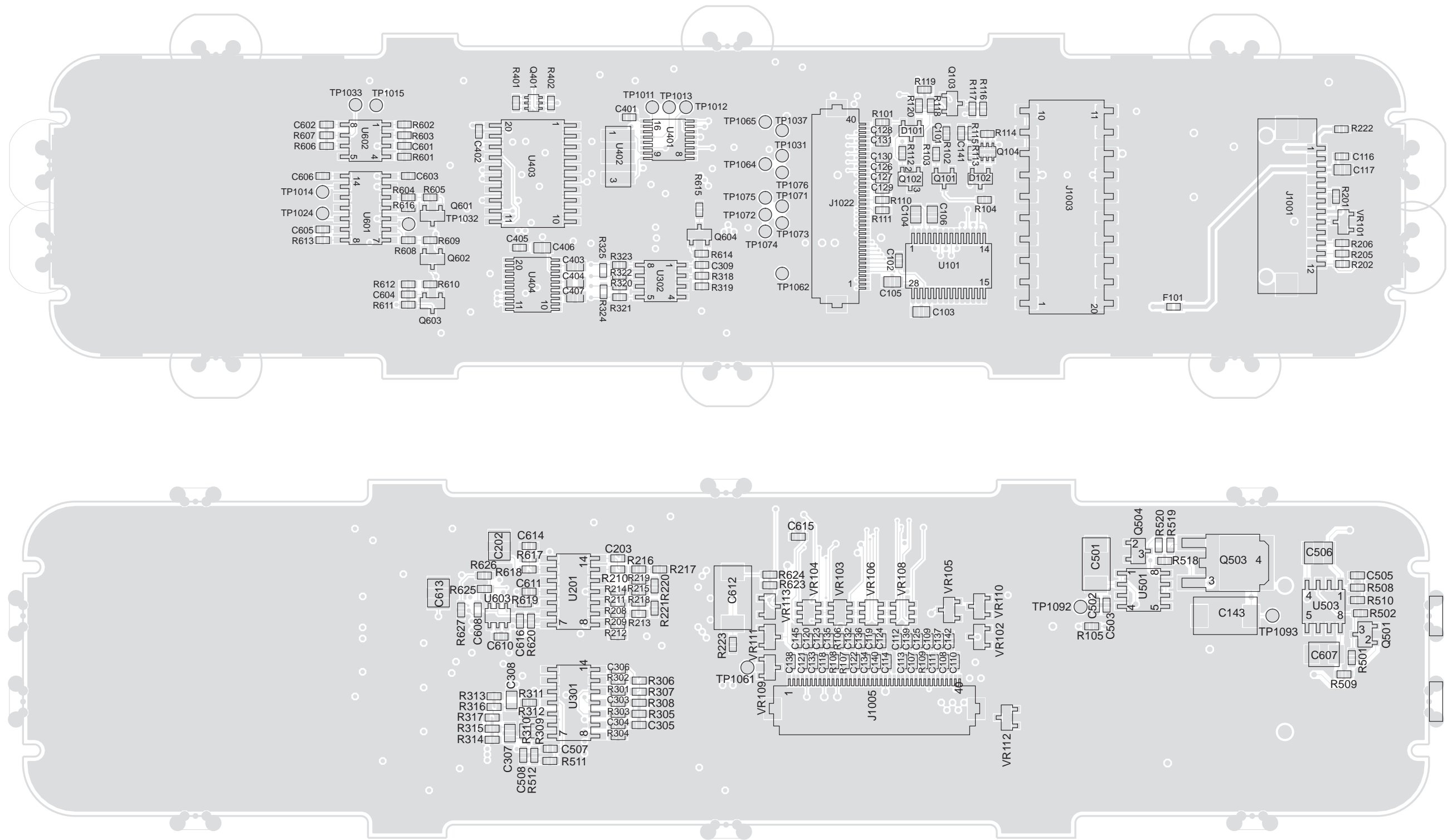

EXPANSION_HEAD / Main Board / (PCB 8466586A01_A) BOTTOM & TOP SIDE

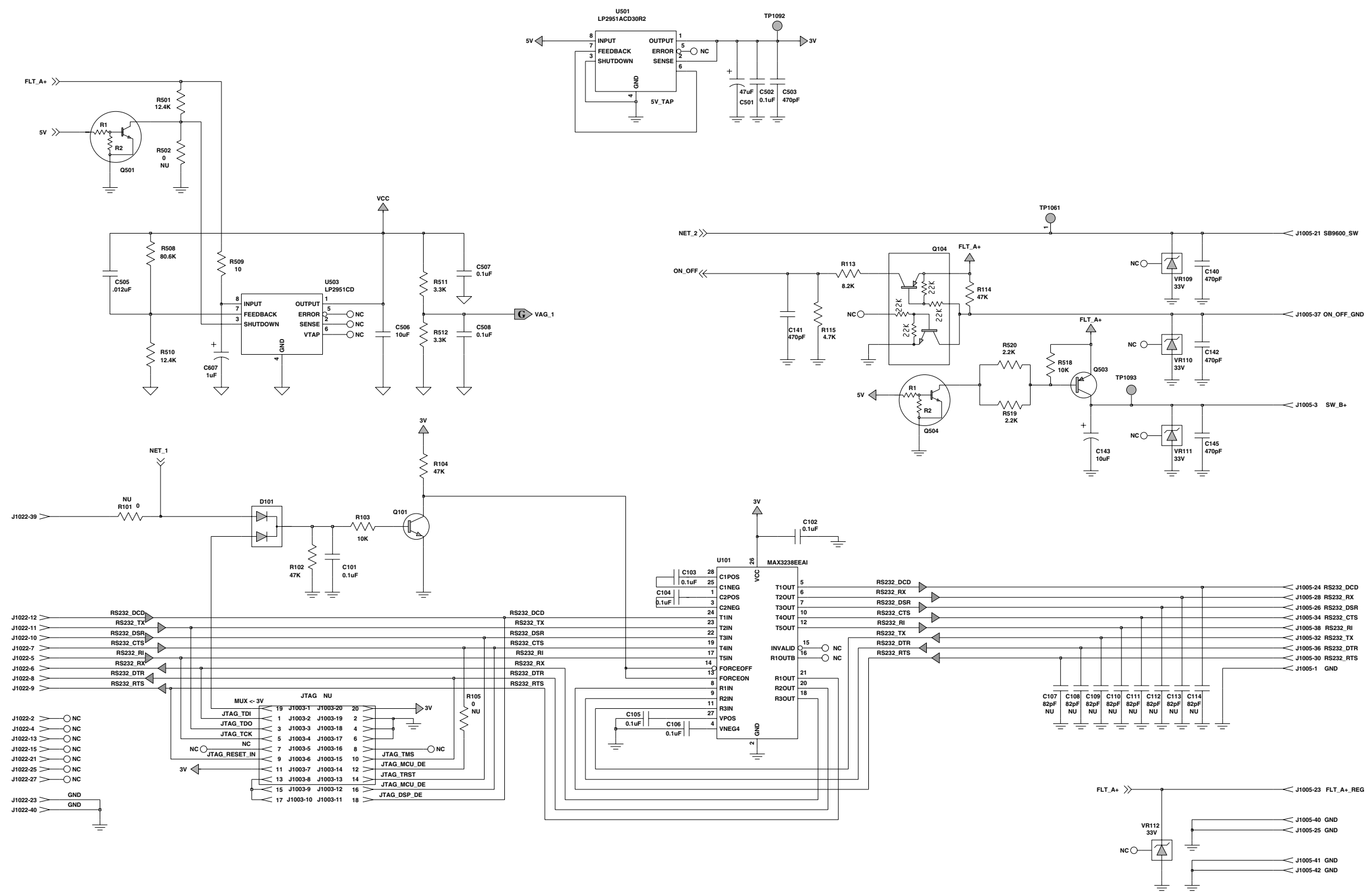

EXPANSION_HEAD / DC Power (PCB 8466586A01_A) / Schematic Diagram 2

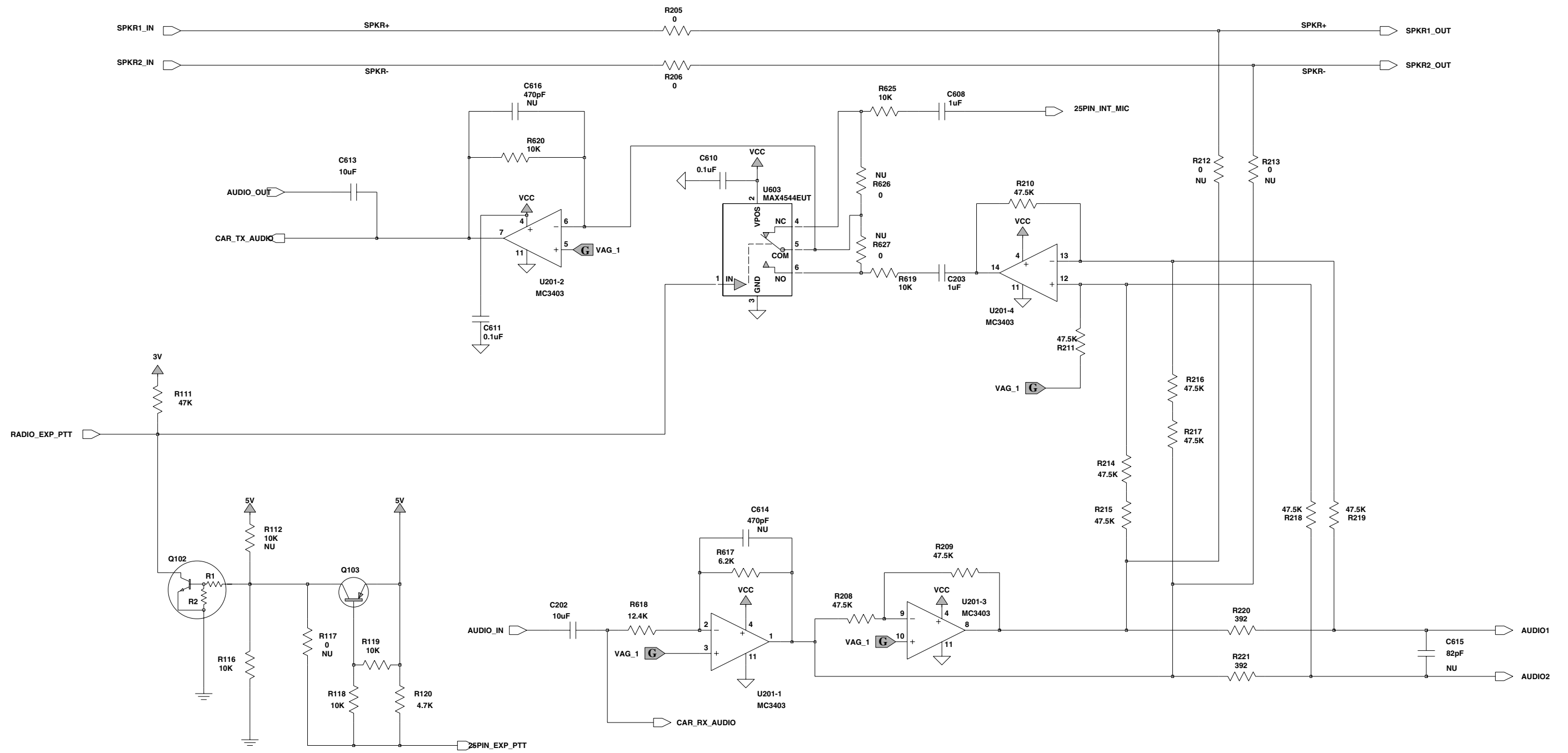

EXPANSION_HEAD / Gabel Hybrid (PCB 8466586A01_A) / Schematic Diagram 3

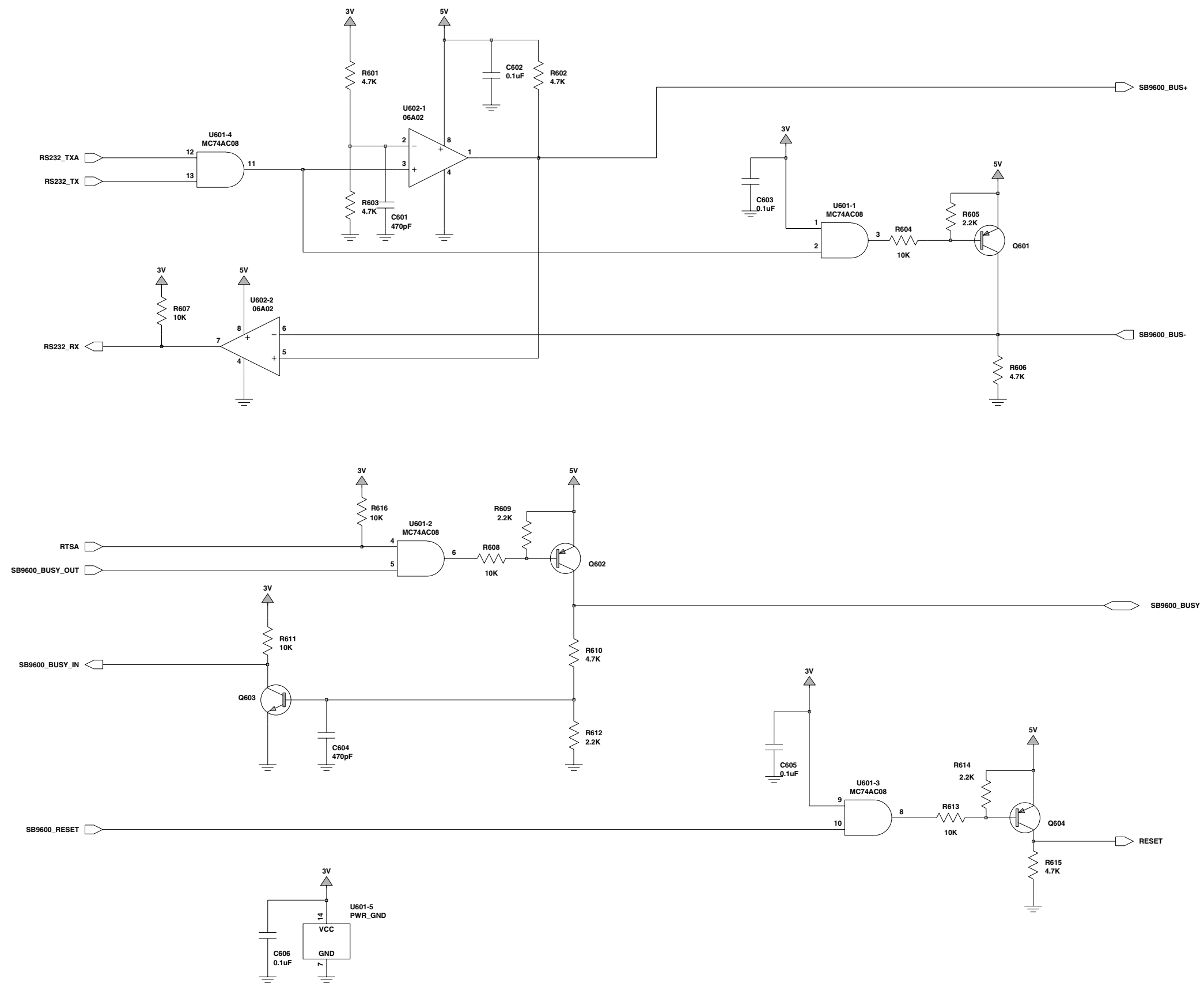

EXPANSION_HEAD / SB9600 Interface (PCB 8466586A01_A) / Schematic Diagram 4

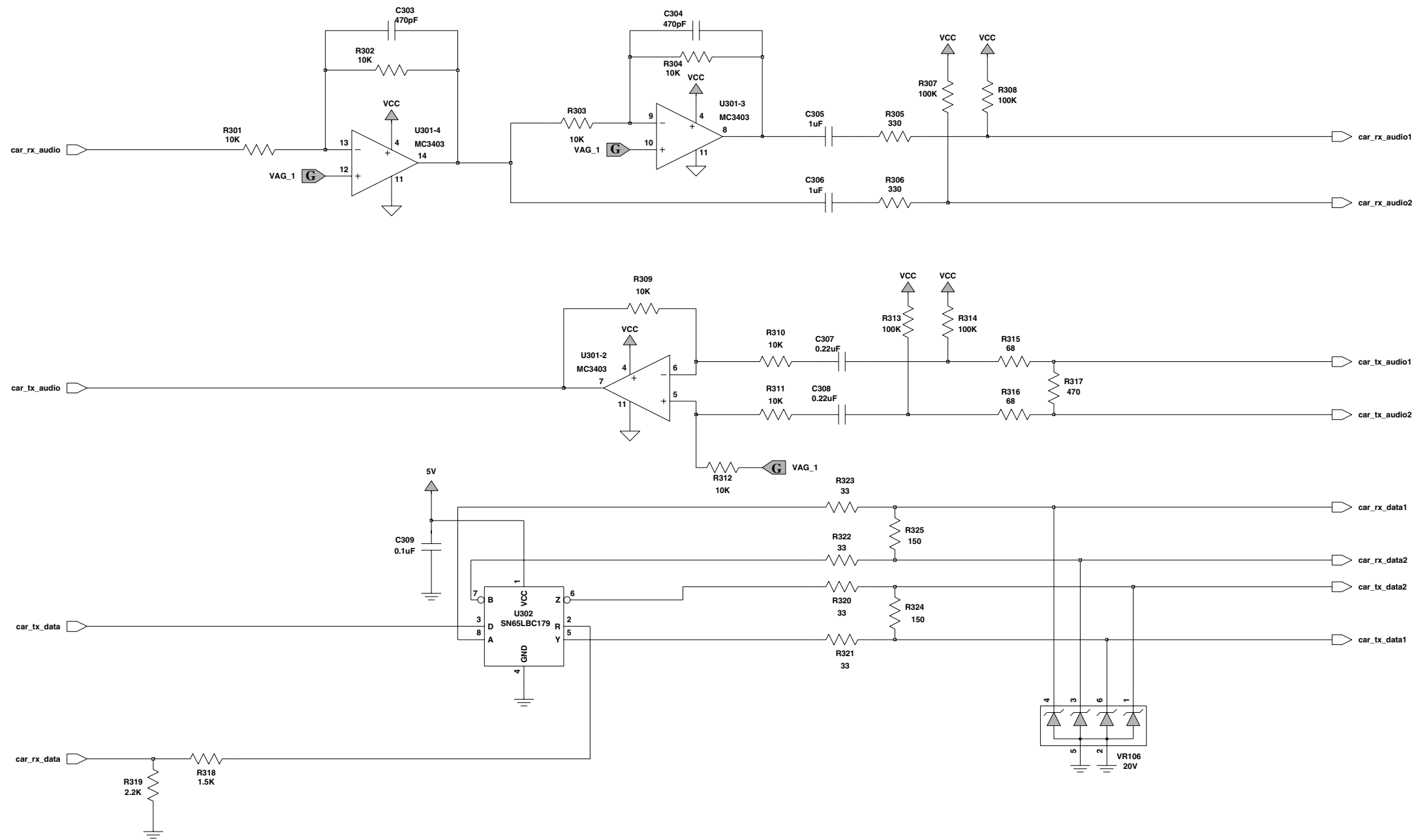

EXPANSION_HEAD / Car Interface (PCB 8466586A01_A) / Schematic Diagram 5

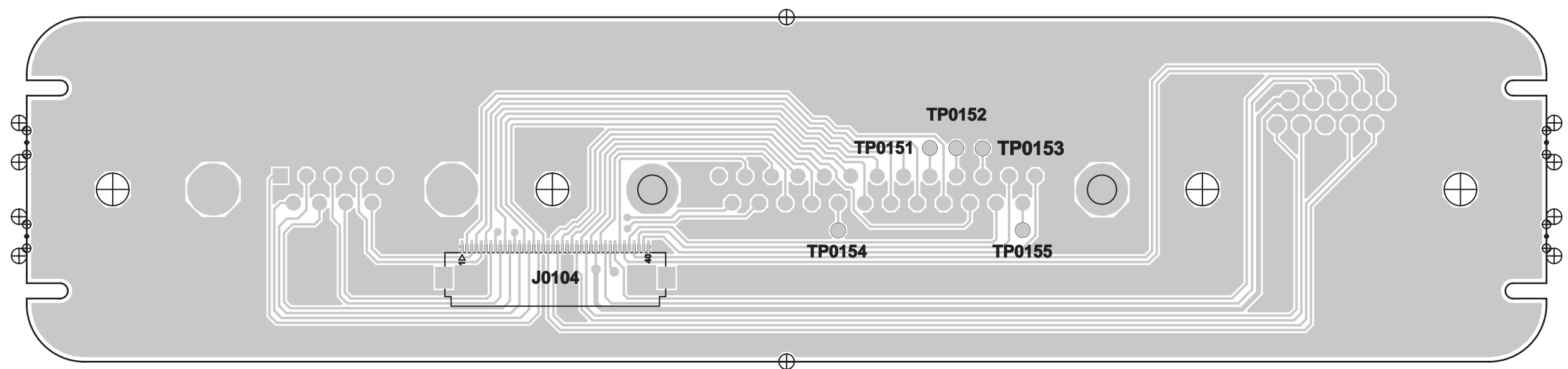
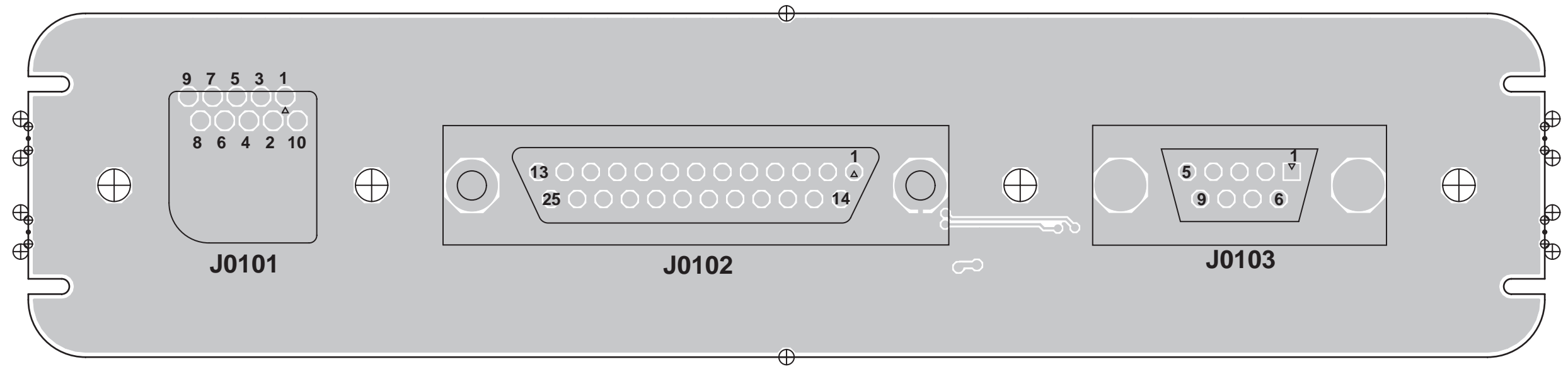

EXPANSION_HEAD / Connector Board (PCB:8464300B06_A) / BOTTOM & TOP SIDE

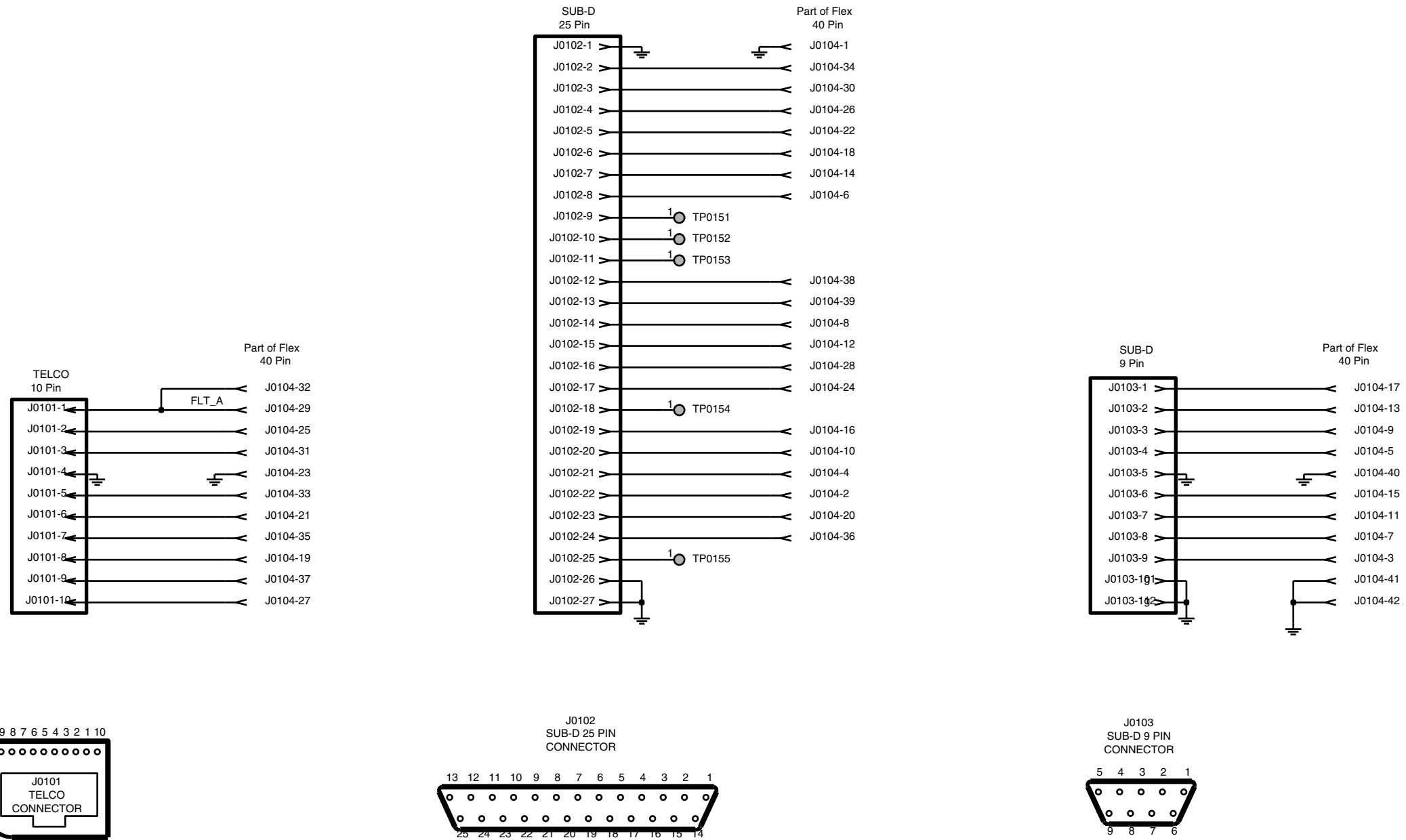

EXPANSION_HEAD (PCB:8464300B06_A) / Connector Board / Schematic Diagram

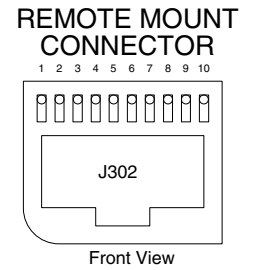
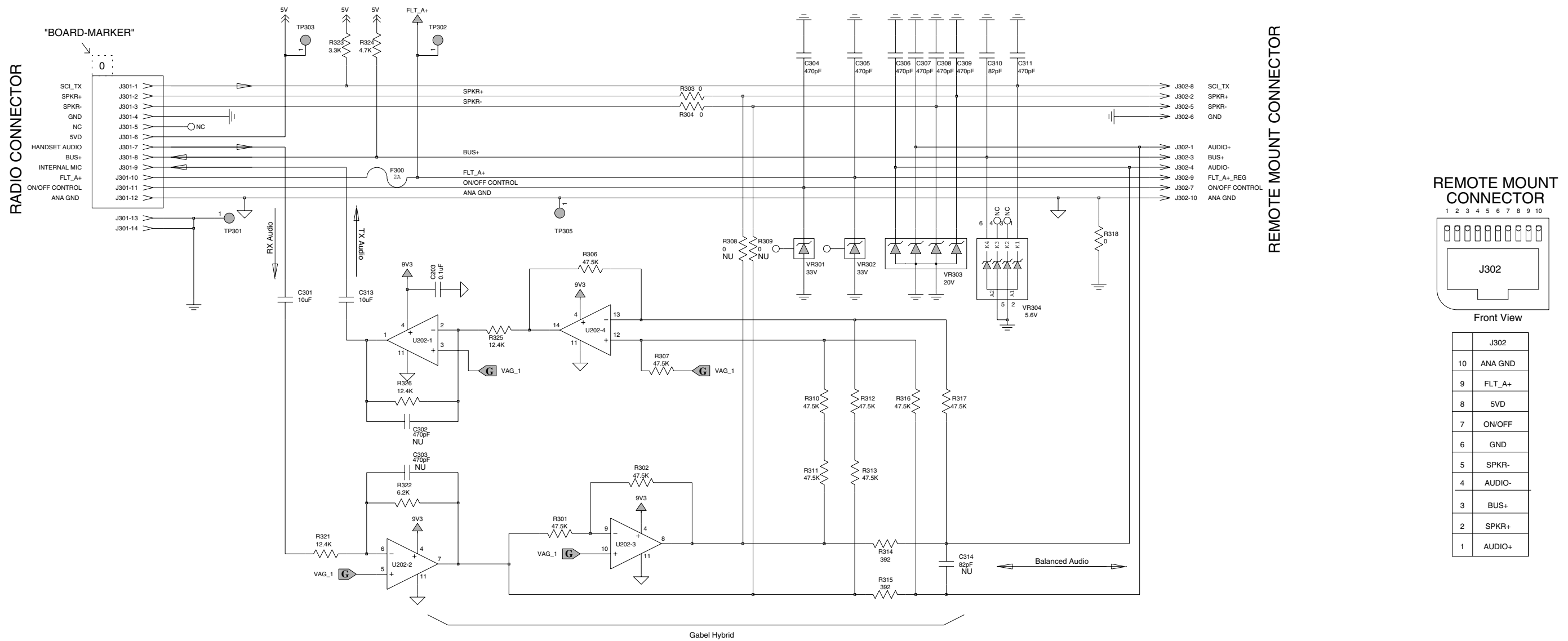

Front View

J302	
10	ANA GND
9	FLT_A+
8	5V D
7	ON/OFF
6	GND
5	SPKR-
4	AUDIO-
3	BUS+
2	SPKR+
1	AUDIO+

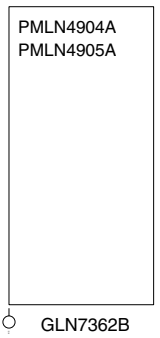
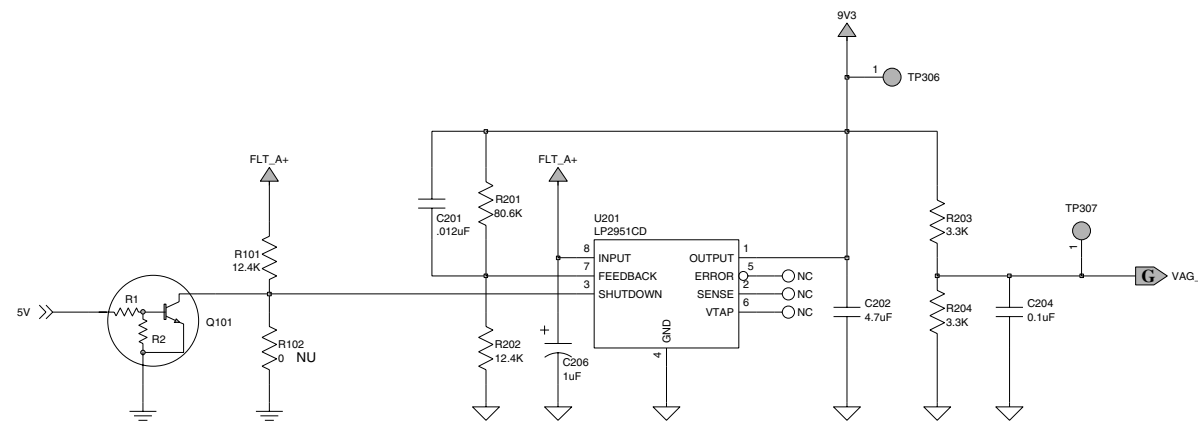

GLN7362B

REMOTE_MOUNT_HEAD (PCB 8471016L02) Schematic Diagram

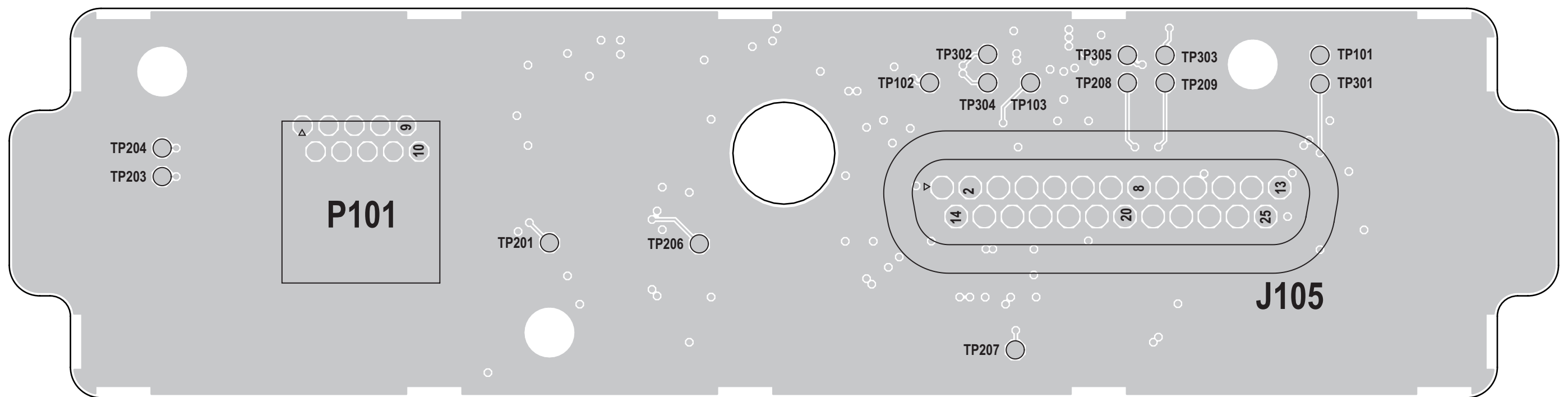
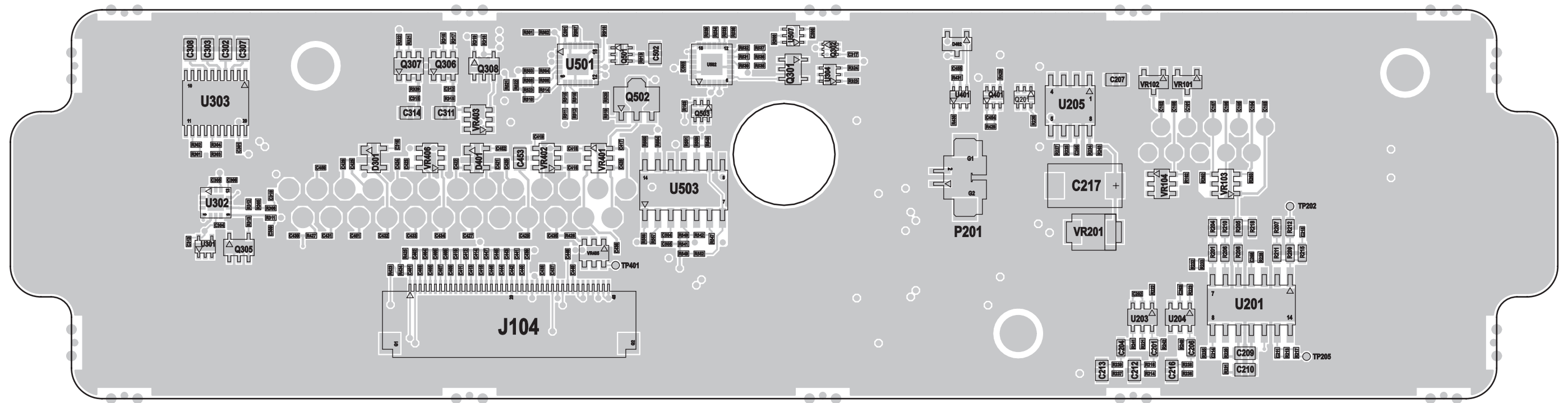

PCB / REMOTE_MOUNT_Back_Housing / (PCB 84966583A01) BOTTOM & TOP SIDE

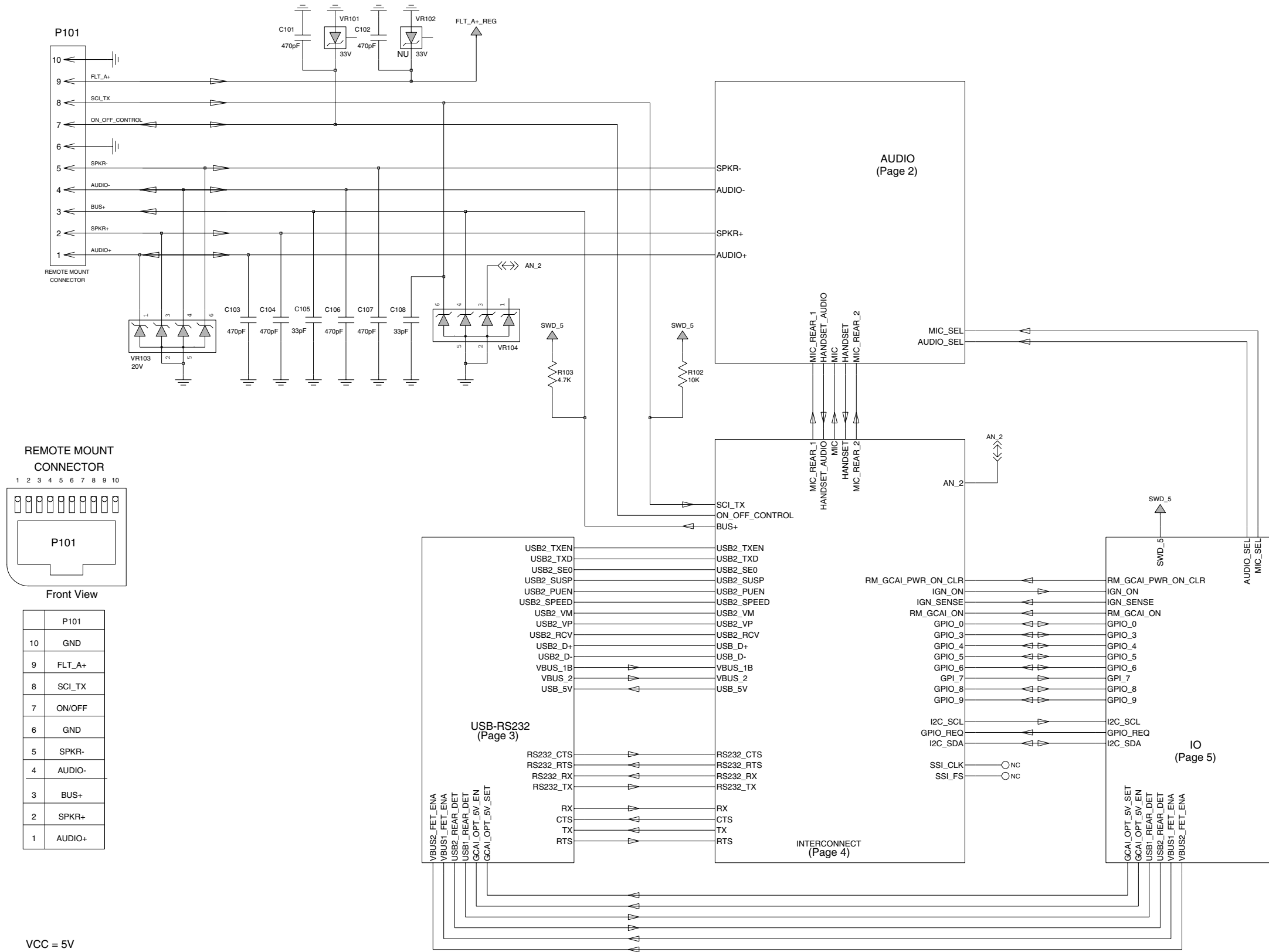

PCB / REMOTE_MOUNT_Back_Housing / (PCB 84966583A01) Schematic Diagram

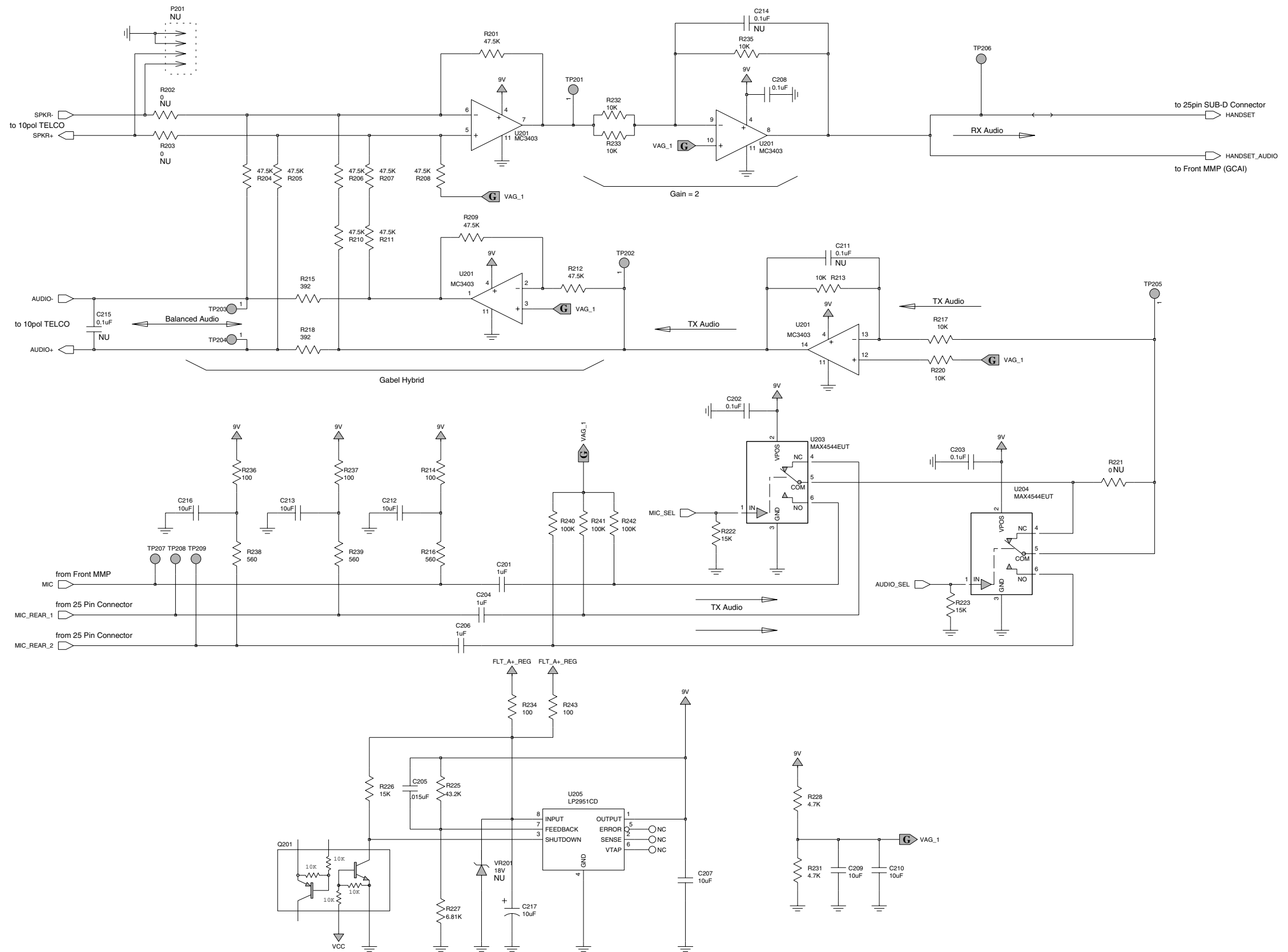

MOTORCYCLE_CONTROL_HEAD (PCB: 8408184Y01) Sheet 2

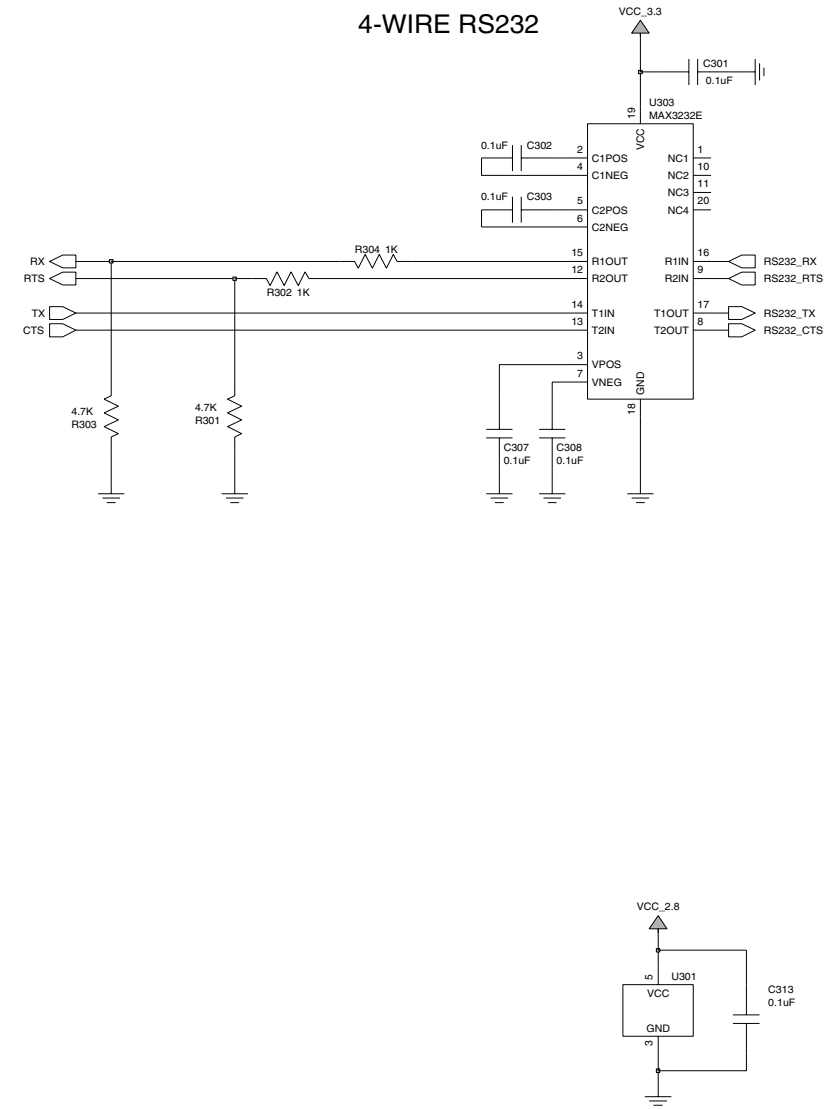
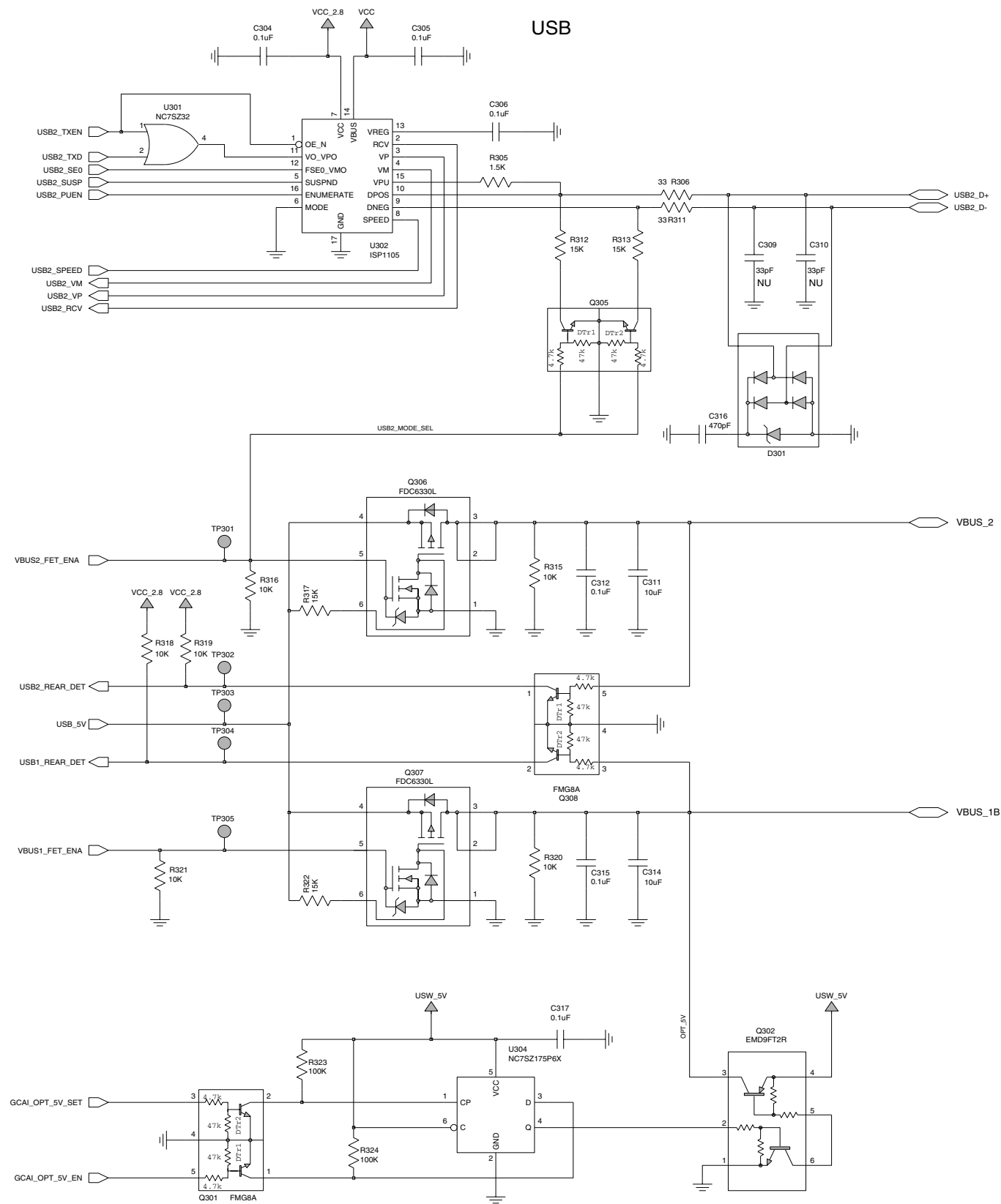

MOTORCYCLE_CONTROL_HEAD (PCB: 8408184Y01) Sheet 2

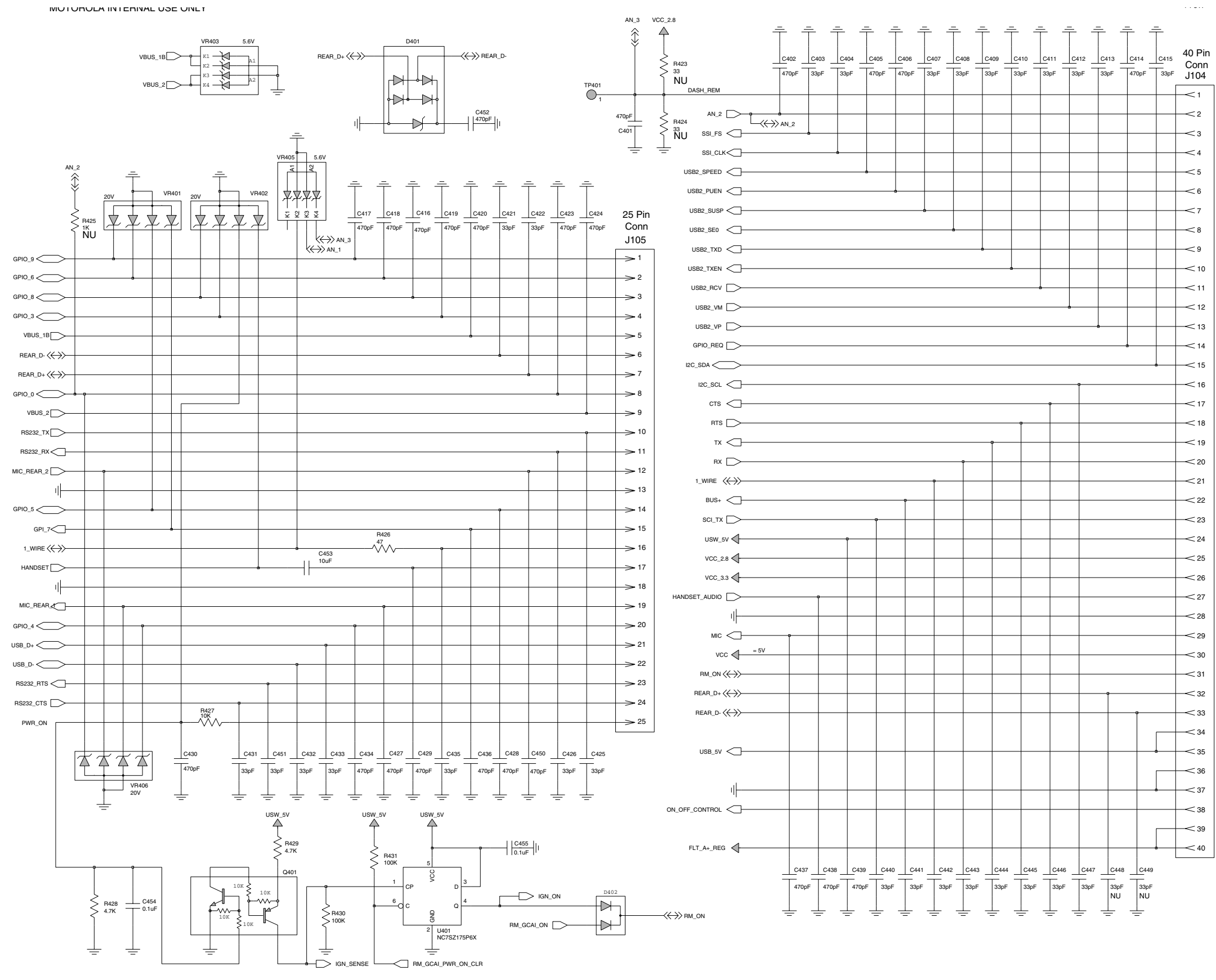

MOTORCYCLE_CONTROL_HEAD (PCB: 8408184Y01) Sheet 2

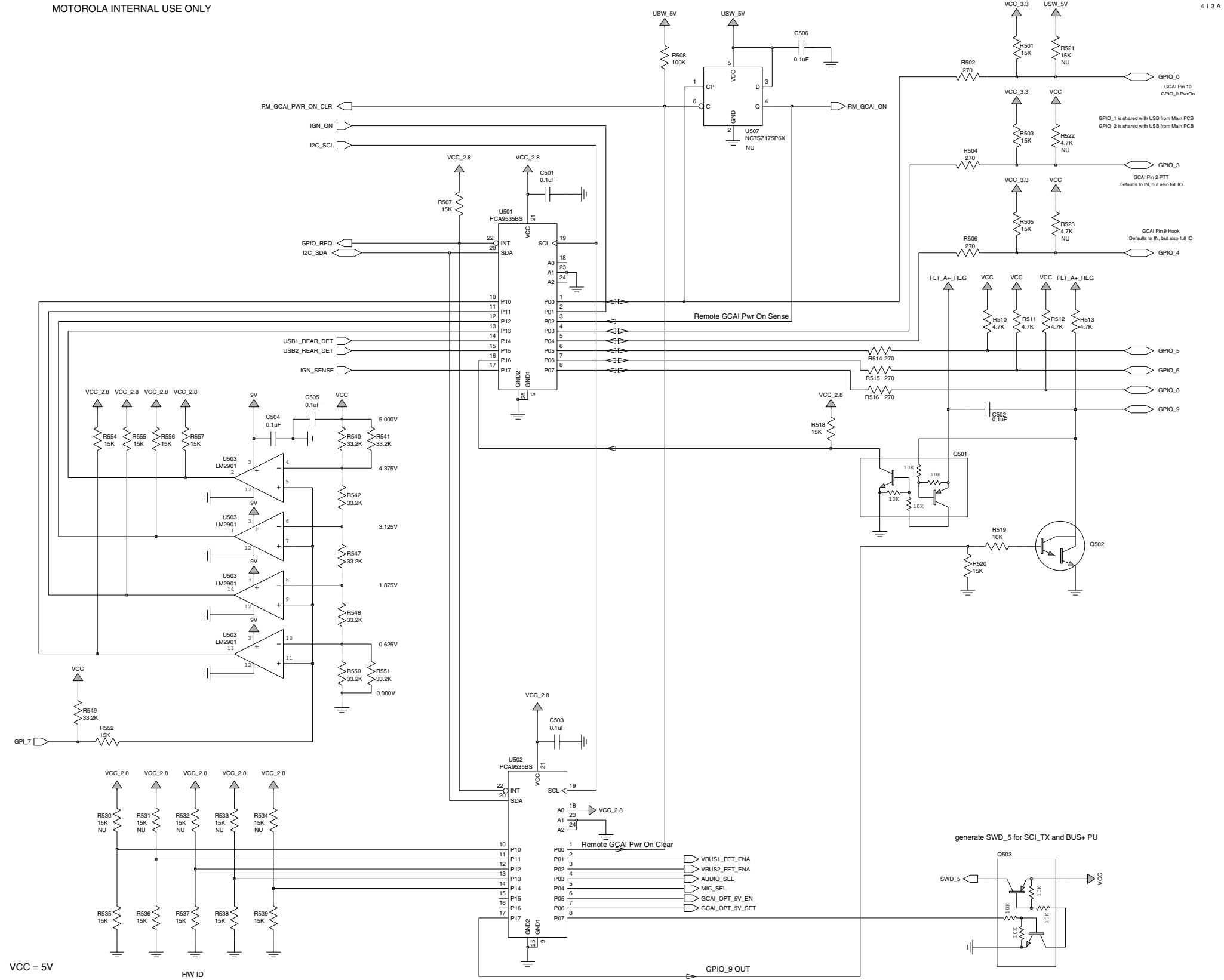

Parts List

Enhanced Control Head (PCB: 8466580A01)

Reference	Motorola PN	Value
C0802	2113945C09	CAP, 470pF
R502	0613952E09	RES, 12.1K
R504	0613952E09	RES, 12.1K
R102	0613952H25	RES, 10
R101	0613952H37	RES, 33
R103	0613952H37	RES, 33
R287	0613952H49	RES, 100
R415	0613952H49	RES, 100
R530	0613952H49	RES, 100
R314	0613952H57	RES, 220
R315	0613952H57	RES, 220
R316	0613952H57	RES, 220
R532	0613952N70	RES, 52.3K
R515	0613952N71	RES, 53.6K
R513	0613952N81	RES, 68.1K
R511	0613952P09	RES, 121K
R509	0613952P22	RES, 165K
R531	0613952P22	RES, 165K
R508	0613952P51	RES, 332K
R510	0613952P81	RES, 681K
R296	0613952Q25	RES, 10
R297	0613952Q25	RES, 10
R533	0613952Q25	RES, 10
R160	0613952Q37	RES, 33
R161	0613952Q37	RES, 33
R163	0613952Q37	RES, 33
R164	0613952Q37	RES, 33
R165	0613952Q37	RES, 33
R166	0613952Q37	RES, 33
R167	0613952Q37	RES, 33
R168	0613952Q37	RES, 33
R258	0613952Q37	RES, 33
R405	0613952Q49	RES, 100
R503	0613952Q49	RES, 100
R330	0613952Q57	RES, 220
R331	0613952Q57	RES, 220
R313	0613952Q73	RES, 1K
R320	0613952Q73	RES, 1K
R358	0613952Q73	RES, 1K
R407	0613952Q73	RES, 1K
R408	0613952Q73	RES, 1K
R409	0613952Q73	RES, 1K
R410	0613952Q73	RES, 1K
R411	0613952Q73	RES, 1K

Reference	Motorola PN	Value
R417	0613952Q73	RES, 1K
R505	0613952Q73	RES, 1K
R512	0613952Q73	RES, 1K
R545	0613952Q73	RES, 1K
R286	0613952Q77	RES, 1.5K
R326	0613952Q77	RES, 1.5K
R414	0613952Q77	RES, 1.5K
R416	0613952Q79	RES, 1.8K
R261	0613952Q81	RES, 2.2K
R262	0613952Q81	RES, 2.2K
R307	0613952Q81	RES, 2.2K
R308	0613952Q81	RES, 2.2K
R401	0613952Q85	RES, 3.3K
R402	0613952Q85	RES, 3.3K
R428	0613952Q85	RES, 3.3K
R155	0613952Q89	RES, 4.7K
R157	0613952Q89	RES, 4.7K
R354	0613952Q89	RES, 4.7K
R406	0613952Q89	RES, 4.7K
R435	0613952Q89	RES, 4.7K
R541	0613952Q89	RES, 4.7K
R547	0613952Q89	RES, 4.7K
R551	0613952Q89	RES, 4.7K
R344	0613952Q91	RES, 5.6K
R214	0613952R01	RES, 10K
R215	0613952R01	RES, 10K
R218	0613952R01	RES, 10K
R219	0613952R01	RES, 10K
R223	0613952R01	RES, 10K
R228	0613952R01	RES, 10K
R230	0613952R01	RES, 10K
R231	0613952R01	RES, 10K
R232	0613952R01	RES, 10K
R233	0613952R01	RES, 10K
R234	0613952R01	RES, 10K
R235	0613952R01	RES, 10K
R237	0613952R01	RES, 10K
R242	0613952R01	RES, 10K
R243	0613952R01	RES, 10K
R244	0613952R01	RES, 10K
R246	0613952R01	RES, 10K
R248	0613952R01	RES, 10K
R249	0613952R01	RES, 10K
R253	0613952R01	RES, 10K
R255	0613952R01	RES, 10K
R256	0613952R01	RES, 10K

Reference	Motorola PN	Value
R264	0613952R01	RES, 10K
R265	0613952R01	RES, 10K
R288	0613952R01	RES, 10K
R290	0613952R01	RES, 10K
R295	0613952R01	RES, 10K
R301	0613952R01	RES, 10K
R303	0613952R01	RES, 10K
R305	0613952R01	RES, 10K
R309	0613952R01	RES, 10K
R310	0613952R01	RES, 10K
R311	0613952R01	RES, 10K
R321	0613952R01	RES, 10K
R323	0613952R01	RES, 10K
R325	0613952R01	RES, 10K
R329	0613952R01	RES, 10K
R333	0613952R01	RES, 10K
R334	0613952R01	RES, 10K
R336	0613952R01	RES, 10K
R337	0613952R01	RES, 10K
R345	0613952R01	RES, 10K
R412	0613952R01	RES, 10K
R421	0613952R01	RES, 10K
R424	0613952R01	RES, 10K
R425	0613952R01	RES, 10K
R426	0613952R01	RES, 10K
R436	0613952R01	RES, 10K
R501	0613952R01	RES, 10K
R507	0613952R01	RES, 10K
R514	0613952R01	RES, 10K
R540	0613952R01	RES, 10K
R542	0613952R01	RES, 10K
R543	0613952R01	RES, 10K
R548	0613952R01	RES, 10K
R549	0613952R01	RES, 10K
R550	0613952R01	RES, 10K
R304	0613952R05	RES, 15K
R306	0613952R05	RES, 15K
R312	0613952R05	RES, 15K
R322	0613952R05	RES, 15K
R324	0613952R05	RES, 15K
R327	0613952R05	RES, 15K
R328	0613952R05	RES, 15K
R357	0613952R05	RES, 15K
R422	0613952R05	RES, 15K
R430	0613952R05	RES, 15K
R423	0613952R12	RES, 30K

Reference	Motorola PN	Value
R427	0613952R12	RES, 30K
R403	0613952R13	RES, 33K
R404	0613952R13	RES, 33K
R506	0613952R13	RES, 33K
R335	0613952R17	RES, 47K
R413	0613952R17	RES, 47K
R429	0613952R17	RES, 47K
R151	0613952R25	RES, 100K
R152	0613952R25	RES, 100K
R153	0613952R25	RES, 100K
R154	0613952R25	RES, 100K
R203	0613952R25	RES, 100K
R207	0613952R25	RES, 100K
R208	0613952R25	RES, 100K
R210	0613952R25	RES, 100K
R211	0613952R25	RES, 100K
R212	0613952R25	RES, 100K
R347	0613952R25	RES, 100K
R348	0613952R25	RES, 100K
R522	0613952R33	RES, 220K
R340	0613952R37	RES, 330K
R341	0613952R37	RES, 330K
R342	0613952R37	RES, 330K
R343	0613952R37	RES, 330K
R520	0613952R37	RES, 330K
R346	0613952R41	RES, 470K
R162	0613952R66	RES, 0
R213	0613952R66	RES, 0
R220	0613952R66	RES, 0
R224	0613952R66	RES, 0
R225	0613952R66	RES, 0
R257	0613952R66	RES, 0
R260	0613952R66	RES, 0
R266	0613952R66	RES, 0
R267	0613952R66	RES, 0
R268	0613952R66	RES, 0
R269	0613952R66	RES, 0
R270	0613952R66	RES, 0
R271	0613952R66	RES, 0
R272	0613952R66	RES, 0
R273	0613952R66	RES, 0
R274	0613952R66	RES, 0
R275	0613952R66	RES, 0
R276	0613952R66	RES, 0
R277	0613952R66	RES, 0
R278	0613952R66	RES, 0

Reference	Motorola PN	Value
R279	0613952R66	RES, 0
R280	0613952R66	RES, 0
R281	0613952R66	RES, 0
R282	0613952R66	RES, 0
R283	0613952R66	RES, 0
R284	0613952R66	RES, 0
R285	0613952R66	RES, 0
R291	0613952R66	RES, 0
R318	0613952R66	RES, 0
R361	0613952R66	RES, 0
R400	0613952R66	RES, 0
R442	0613952R66	RES, 0
R443	0613952R66	RES, 0
R523	0613952R66	RES, 0
R534	0613952R66	RES, 0
R535	0613952R66	RES, 0
R536	0613952R66	RES, 0
R537	0613952R66	RES, 0
R539	0613952R66	RES, 0
R544	0613952R66	RES, 0
R606	0613952R66	RES, 0
R607	0613952R66	RES, 0
R608	0613952R66	RES, 0
R609	0613952R66	RES, 0
R612	0613952R66	RES, 0
R613	0613952R66	RES, 0
R221	0613952R74	RES, 10MEG
R521	0613952R74	RES, 10MEG
J102	0916162H02	pin CONN_J
J401	0916875H01	pin CONN_J
J101	0964501H02	CONN_J
J603	0971065L01	pin CONN_J
J403	0971315L01	CONN_J
J201	0988866N01	pin CONN_J
C523	2113944A25	CAP, 10pF
C532	2113944A26	CAP, 12pF
C204	2113944A28	CAP, 18pF
C205	2113944A28	CAP, 18pF
C531	2113944A28	CAP, 18pF
C518	2113944A29	CAP, 22pF
C258	2113944A31	CAP, 33pF
C259	2113944A31	CAP, 33pF
C260	2113944A31	CAP, 33pF
C264	2113944A31	CAP, 33pF
C265	2113944A31	CAP, 33pF
C270	2113944A31	CAP, 33pF

Reference	Motorola PN	Value
C272	2113944A31	CAP, 33pF
C277	2113944A31	CAP, 33pF
C289	2113944A31	CAP, 33pF
C292	2113944A31	CAP, 33pF
C605	2113944A31	CAP, 33pF
C606	2113944A31	CAP, 33pF
C625	2113944A31	CAP, 33pF
C626	2113944A31	CAP, 33pF
C627	2113944A31	CAP, 33pF
C629	2113944A31	CAP, 33pF
C630	2113944A31	CAP, 33pF
C615	2113944A38	CAP, 82pF
C616	2113944A38	CAP, 82pF
C617	2113944A38	CAP, 82pF
C618	2113944A38	CAP, 82pF
C619	2113944A38	CAP, 82pF
C620	2113944A38	CAP, 82pF
C621	2113944A38	CAP, 82pF
C622	2113944A38	CAP, 82pF
C623	2113944A38	CAP, 82pF
C628	2113944A38	CAP, 82pF
C631	2113944A38	CAP, 82pF
C634	2113944A38	CAP, 82pF
C635	2113944A38	CAP, 82pF
C519	2113944A40	CAP, 100pF
C524	2113944A42	CAP, 150pF
C101	2113944C06	CAP, 470pF
C102	2113944C06	CAP, 470pF
C104	2113944C06	CAP, 470pF
C105	2113944C06	CAP, 470pF
C108	2113944C06	CAP, 470pF
C109	2113944C06	CAP, 470pF
C112	2113944C06	CAP, 470pF
C113	2113944C06	CAP, 470pF
C114	2113944C06	CAP, 470pF
C116	2113944C06	CAP, 470pF
C121	2113944C06	CAP, 470pF
C407	2113944C06	CAP, 470pF
C408	2113944C06	CAP, 470pF
C501	2113944C06	CAP, 470pF
C504	2113944C06	CAP, 470pF
C601	2113944C06	CAP, 470pF
C103	2113944C36	CAP, 33pF
C107	2113944C36	CAP, 33pF
C110	2113944C43	CAP, 82pF
C115	2113944C43	CAP, 82pF

Reference	Motorola PN	Value
C118	2113944C43	CAP, 82pF
C244	2113945A05	CAP, 470pF
C245	2113945A05	CAP, 470pF
C328	2113945A05	CAP, 470pF
C414	2113945A05	CAP, 470pF
C602	2113945A05	CAP, 470pF
C604	2113945A05	CAP, 470pF
C607	2113945A05	CAP, 470pF
C608	2113945A05	CAP, 470pF
C609	2113945A05	CAP, 470pF
C611	2113945A05	CAP, 470pF
C612	2113945A05	CAP, 470pF
C613	2113945A05	CAP, 470pF
C614	2113945A05	CAP, 470pF
C624	2113945A05	CAP, 470pF
C632	2113945A05	CAP, 470pF
C633	2113945A05	CAP, 470pF
C636	2113945A05	CAP, 470pF
C637	2113945A05	CAP, 470pF
C506	2113945C02	CAP, .01uF
C505	2113945C31	CAP, 0.1uF
C206	2113946B04	CAP, 0.1uF
C220	2113946B04	CAP, 0.1uF
C221	2113946B04	CAP, 0.1uF
C223	2113946B04	CAP, 0.1uF
C224	2113946B04	CAP, 0.1uF
C225	2113946B04	CAP, 0.1uF
C226	2113946B04	CAP, 0.1uF
C227	2113946B04	CAP, 0.1uF
C228	2113946B04	CAP, 0.1uF
C229	2113946B04	CAP, 0.1uF
C230	2113946B04	CAP, 0.1uF
C231	2113946B04	CAP, 0.1uF
C232	2113946B04	CAP, 0.1uF
C233	2113946B04	CAP, 0.1uF
C241	2113946B04	CAP, 0.1uF
C255	2113946B04	CAP, 0.1uF
C256	2113946B04	CAP, 0.1uF
C257	2113946B04	CAP, 0.1uF
C261	2113946B04	CAP, 0.1uF
C262	2113946B04	CAP, 0.1uF
C263	2113946B04	CAP, 0.1uF
C267	2113946B04	CAP, 0.1uF
C268	2113946B04	CAP, 0.1uF
C269	2113946B04	CAP, 0.1uF
C271	2113946B04	CAP, 0.1uF

Reference	Motorola PN	Value
C273	2113946B04	CAP, 0.1uF
C274	2113946B04	CAP, 0.1uF
C275	2113946B04	CAP, 0.1uF
C276	2113946B04	CAP, 0.1uF
C279	2113946B04	CAP, 0.1uF
C280	2113946B04	CAP, 0.1uF
C281	2113946B04	CAP, 0.1uF
C282	2113946B04	CAP, 0.1uF
C283	2113946B04	CAP, 0.1uF
C284	2113946B04	CAP, 0.1uF
C285	2113946B04	CAP, 0.1uF
C286	2113946B04	CAP, 0.1uF
C287	2113946B04	CAP, 0.1uF
C288	2113946B04	CAP, 0.1uF
C291	2113946B04	CAP, 0.1uF
C293	2113946B04	CAP, 0.1uF
C301	2113946B04	CAP, 0.1uF
C324	2113946B04	CAP, 0.1uF
C326	2113946B04	CAP, 0.1uF
C401	2113946B04	CAP, 0.1uF
C402	2113946B04	CAP, 0.1uF
C403	2113946B04	CAP, 0.1uF
C404	2113946B04	CAP, 0.1uF
C405	2113946B04	CAP, 0.1uF
C406	2113946B04	CAP, 0.1uF
C409	2113946B04	CAP, 0.1uF
C413	2113946B04	CAP, 0.1uF
C421	2113946B04	CAP, 0.1uF
C422	2113946B04	CAP, 0.1uF
C516	2113946B04	CAP, 0.1uF
C522	2113946B04	CAP, 0.1uF
C528	2113946B04	CAP, 0.1uF
C529	2113946B04	CAP, 0.1uF
C533	2113946B04	CAP, 0.1uF
C540	2113946B04	CAP, 0.1uF
C541	2113946B04	CAP, 0.1uF
C542	2113946B04	CAP, 0.1uF
C545	2113946B04	CAP, 0.1uF
C546	2113946B04	CAP, 0.1uF
C547	2113946B04	CAP, 0.1uF
C234	2113946D02	CAP, 1.0uF
C266	2113946D02	CAP, 1.0uF
C278	2113946D02	CAP, 1.0uF
C290	2113946D02	CAP, 1.0uF
C295	2113946D02	CAP, 1.0uF
C242	2113956B54	CAP, 10uF

Reference	Motorola PN	Value
C243	2113956B54	CAP, 10uF
C294	2113956B54	CAP, 10uF
C327	2113956B54	CAP, 10uF
C410	2113956B54	CAP, 10uF
C415	2113956B54	CAP, 10uF
C416	2113956B54	CAP, 10uF
C513	2113956B54	CAP, 10uF
C517	2113956B54	CAP, 10uF
C520	2113956B54	CAP, 10uF
C521	2113956B54	CAP, 10uF
C525	2113956B54	CAP, 10uF
C526	2113956B54	CAP, 10uF
C527	2113956B54	CAP, 10uF
C534	2113956B54	CAP, 10uF
C610	2113956B54	CAP, 10uF
C120	2113956C37	CAP, 10uF
C325	2113956D58	CAP, 22uF
C507	2113956D58	CAP, 22uF
C508	2113956D58	CAP, 22uF
C509	2113956D58	CAP, 22uF
C510	2113956D58	CAP, 22uF
C511	2113956D58	CAP, 22uF
C512	2113956D58	CAP, 22uF
C502	2313960J01	CAPP, 10uF
C503	2313960J01	CAPP, 10uF
C514	2314030J28	CAPP, 22uF
L502	2487956V01	IDCTR, 22uH
L501	2489932S02	IDCTR, 33uH
L505	2489932S02	IDCTR, 33uH
L507	2489932S02	IDCTR, 33uH
L503	2589195N04	IDCTR, 4.7uH
L504	2589195N04	IDCTR, 4.7uH
SH501	2616535H01	SHIELD
M102	3264646H01	CONTACT
M104	3264646H01	CONTACT
M105	3264646H01	CONTACT
M106	3264646H01	CONTACT
M109	3264646H01	CONTACT
M111	3264646H01	CONTACT
M201	3989655N03	CONTACT
S501	4015040C01	SWITCH
Y201	4802582S85	XTAL
Q322	4805921T28	FMG8A
Q323	4805921T28	FMG8A
Q324	4805921T28	FMG8A
Y501	4809995L20	MC146

Reference	Motorola PN	Value
Q201	4813973M07	MMBT3904
Q305	4813973M07	MMBT3904
Q403	4813973M07	MMBT3904
Q410	4813973M07	MMBT3904
D301	4813978A19	MBR120LSFT1
D302	4813978A25	BAT54HT1G
D502	4813978A25	BAT54HT1G
D507	4813978A25	BAT54HT1G
D350	4813978C02	MMBD6100
D503	4813978C02	MMBD6100
D505	4813978C02	MMBD6100
D510	4813978C02	MMBD6100
D511	4813978C02	MMBD6100
D513	4813978C02	MMBD6100
D501	4813978N08	MBRS130
VR102	4813979C11	MMQA20VT1
VR101	4813979P10	MMQA5V6T1
VR401	4813979P10	MMQA5V6T1
VR501	4813979P10	MMQA5V6T1
VR502	4814026A19	1SMB5931B
Q202	4815272H01	EMD9FT2R
Q301	4815272H01	EMD9FT2R
Q325	4815272H01	EMD9FT2R
Q352	4815272H01	EMD9FT2R
Q404	4815272H01	EMD9FT2R
Q405	4815272H01	EMD9FT2R
Q411	4815272H01	EMD9FT2R
Q412	4815272H01	EMD9FT2R
Q500	4815272H01	EMD9FT2R
Q501	4815272H01	EMD9FT2R
Q502	4815272H01	EMD9FT2R
Q503	4815272H01	EMD9FT2R
Q504	4815272H01	EMD9FT2R
Q505	4815272H01	EMD9FT2R
Q506	4815272H01	EMD9FT2R
Q507	4815272H01	EMD9FT2R
Q508	4815272H01	EMD9FT2R
D401	4815814H01	HT-S91UD
D402	4815814H01	HT-S91UD
D101	4866544A01	SR05
U301	5102836C11	1 FSA4157L6X_NL
U321	5102836C11	1 FSA4157L6X_NL
U322	5102836C11	1 FSA4157L6X_NL
U326	5102836C11	1 FSA4157L6X_NL
U327	5102836C11	1 FSA4157L6X_NL
U510	5102836C11	1 FSA4157L6X_NL

Reference	Motorola PN	Value
U511	5102836C11	1 FSA4157L6X_NL
U512	5102836C11	1 FSA4157L6X_NL
U507	5109512F66	LP2985
U328	5109817F77	LMV7275
U421	5109817F77	LMV7275
U422	5109817F77	LMV7275
U504	5109920D39	TPS62220
U505	5109920D39	TPS62220
U503	5109920D44	LT1937
U206	5114000B39	74VHC125
U207	5114000B39	74VHC125
U210	5114000B39	74VHC125
U420	5114000B39	74VHC125
U502	5114004A35	NCP301
U403	5114007A43	NL17SZ14
U404	5114007A43	NL17SZ14
U508	5114007A43	NL17SZ14
U208	5114007A47	NC7SZ32
U506	5114014A22	LP2951CD
U302	5115007H01	0 SN74LVC1T45
U303	5115007H01	0 SN74LVC1T45
U304	5115007H01	0 SN74LVC1T45
U323	5115007H01	0 SN74LVC1T45
U325	5115007H01	0 SN74LVC1T45
U324	5164015H50	TPS2041B
Q326	5166540A01	FDC6330L
Q401	5166540A01	FDC6330L
U515	5185319Y01	74HC4060A
U205	5185941F17	MT48H8M16LF
U501	5185941F48	LM2676
U201	5185941F53	0 EIM_BLOCK
U209	5185941F65	MC74LVX373
U204	5185956E43	_75 28F128W18BD60
U401	5186311J07	NC7SZ175P6X
U402	5186311J07	NC7SZ175P6X
U509	5186311J07	NC7SZ175P6X
U513	5189263U10	TPS71501DCKR
C201	NOTPLACED	CAP, 0.1uF
C202	NOTPLACED	CAP, 18pF
C203	NOTPLACED	CAP, 18pF
C350	NOTPLACED	CAP, 0.1uF
C352	NOTPLACED	CAP, 0.1uF
C515	NOTPLACED	CAP, 1uF
C530	NOTPLACED	CAP, 100pF
C535	NOTPLACED	CAP, 0.1uF
C536	NOTPLACED	CAP, 0.1uF

Reference	Motorola PN	Value
C544	NOTPLACED	CAP, 0.1uF
D304	NOTPLACED	12M04
D504	NOTPLACED	MMBD6100
D506	NOTPLACED	MMBD6100
J202	NOTPLACED	CONN_P
M101	NOTPLACED	CONTACT
M103	NOTPLACED	CONTACT
M107	NOTPLACED	CONTACT
M108	NOTPLACED	CONTACT
M110	NOTPLACED	CONTACT
M112	NOTPLACED	CONTACT
M113	NOTPLACED	CONTACT
M114	NOTPLACED	CONTACT
M115	NOTPLACED	CONTACT
M116	NOTPLACED	CONTACT
Q327	NOTPLACED	EMD9FT2R
Q350	NOTPLACED	EMD9FT2R
Q351	NOTPLACED	FMG8A
Q353	NOTPLACED	FMG8A
R156	NOTPLACED	RES, 100K
R201	NOTPLACED	RES, 100K
R202	NOTPLACED	RES, 100K
R204	NOTPLACED	RES, 100K
R205	NOTPLACED	RES, 0
R206	NOTPLACED	RES, 100K
R209	NOTPLACED	RES, 100K
R216	NOTPLACED	RES, 10MEG
R217	NOTPLACED	RES, 470K
R222	NOTPLACED	RES, 10MEG
R226	NOTPLACED	RES, 0
R227	NOTPLACED	RES, 0
R236	NOTPLACED	RES, 10K
R240	NOTPLACED	RES, 10K
R241	NOTPLACED	RES, 10K
R245	NOTPLACED	RES, 10K
R247	NOTPLACED	RES, 10K
R250	NOTPLACED	RES, 10K
R251	NOTPLACED	RES, 10K
R252	NOTPLACED	RES, 10K
R254	NOTPLACED	RES, 10K
R259	NOTPLACED	RES, 0
R263	NOTPLACED	RES, 0
R289	NOTPLACED	RES, 10K
R317	NOTPLACED	RES, 0
R319	NOTPLACED	RES, 15K
R332	NOTPLACED	RES, 10K

Reference	Motorola PN	Value
R338	NOTPLACED	RES, 0
R339	NOTPLACED	RES, 330
R350	NOTPLACED	RES, 0
R351	NOTPLACED	RES, 100K
R352	NOTPLACED	RES, 100K
R355	NOTPLACED	RES, 100K
R359	NOTPLACED	RES, 0
R360	NOTPLACED	RES, 0
R399	NOTPLACED	RES, 0
R440	NOTPLACED	RES, 0
R441	NOTPLACED	RES, 0
R444	NOTPLACED	RES, 0
R524	NOTPLACED	RES, 0
R529	NOTPLACED	RES, 0
R538	NOTPLACED	RES, 0
R602	NOTPLACED	RES, 0
R603	NOTPLACED	RES, 0
R604	NOTPLACED	RES, 0
R605	NOTPLACED	RES, 0
R610	NOTPLACED	RES, 0
R611	NOTPLACED	RES, 0
R614	NOTPLACED	RES, 0
S401	NOTPLACED	SWITCH
SH201	NOTPLACED	SHIELD
SH502	NOTPLACED	SHIELD
U202	NOTPLACED	MC74HC1GU04D
U203	NOTPLACED	NL17SZ14
U211	NOTPLACED	74VHC125
U350	NOTPLACED	NC7SZ175P6X
U352	NOTPLACED	NC7SZ175P6X
Y202	NOTPLACED	CC4V

Expansion Head / Main Board (PCB 8466586A01)

Reference	Motorola PN	Value
C101	2113945C31	CAPACITOR, FIXED, .1UF, +10%, -10%, 50V-DC,
C102	2113945C31	CAPACITOR, FIXED, .1UF, +10%, -10%, 50V-DC,
C103	2113945G91	CAPACITOR, FIXED, .1UF, +10%, -10%, 50V-DC,
C104	2113945G91	CAPACITOR, FIXED, .1UF, +10%, -10%, 50V-DC,
C105	2113945G91	CAPACITOR, FIXED, .1UF, +10%, -10%, 50V-DC,
C106	2113945G91	CAPACITOR, FIXED, .1UF, +10%, -10%, 50V-DC,
C107	2113944C43	CAPACITOR, CHIP, 82PF, +5%, -5%, 50V-DC

Reference	Motorola PN	Value
C108	2113944C43	CAPACITOR, CHIP, 82PF, +5%, -5%, 50V-DC
C109	2113944C43	CAPACITOR, CHIP, 82PF, +5%, -5%, 50V-DC
C110	2113944C43	CAPACITOR, CHIP, 82PF, +5%, -5%, 50V-DC
C111	2113944C43	CAPACITOR, CHIP, 82PF, +5%, -5%, 50V-DC
C112	2113944C43	CAPACITOR, CHIP, 82PF, +5%, -5%, 50V-DC
C113	2113944C43	CAPACITOR, CHIP, 82PF, +5%, -5%, 50V-DC
C114	2113944C43	CAPACITOR, CHIP, 82PF, +5%, -5%, 50V-DC
C116	2113945L17	CAPACITOR, FIXED, 470PF, +5%, -5%, 50V-DC
C117	2113945G91	CAPACITOR, FIXED, .1UF, +10%, -10%, 50V-DC
C118	2113945L17	CAPACITOR, FIXED, 470PF, +5%, -5%, 50V-DC
C119	2113945L17	CAPACITOR, FIXED, 470PF, +5%, -5%, 50V-DC
C120	2113944C43	CAPACITOR, CHIP, 82PF, +5%, -5%, 50V-DC
C121	2113945L17	CAPACITOR, FIXED, 470PF, +5%, -5%, 50V-DC
C122	2113944C43	CAPACITOR, CHIP, 82PF, +5%, -5%, 50V-DC
C123	2113945L17	CAPACITOR, FIXED, 470PF, +5%, -5%, 50V-DC
C124	2113945L17	CAPACITOR, FIXED, 470PF, +5%, -5%, 50V-DC
C125	2113945L17	CAPACITOR, FIXED, 470PF, +5%, -5%, 50V-DC
C126	2113944C43	CAPACITOR, CHIP, 82PF, +5%, -5%, 50V-DC
C127	2113944C43	CAPACITOR, CHIP, 82PF, +5%, -5%, 50V-DC
C128	2113944C43	CAPACITOR, CHIP, 82PF, +5%, -5%, 50V-DC
C129	2113944C43	CAPACITOR, CHIP, 82PF, +5%, -5%, 50V-DC
C130	2113944C43	CAPACITOR, CHIP, 82PF, +5%, -5%, 50V-DC
C131	2113944C43	CAPACITOR, CHIP, 82PF, +5%, -5%, 50V-DC
C132	2113944C43	CAPACITOR, CHIP, 82PF, +5%, -5%, 50V-DC
C133	2113944C43	CAPACITOR, CHIP, 82PF, +5%, -5%, 50V-DC
C134	2113944C43	CAPACITOR, CHIP, 82PF, +5%, -5%, 50V-DC
C135	2113944C43	CAPACITOR, CHIP, 82PF, +5%, -5%, 50V-DC
C136	2113944C43	CAPACITOR, CHIP, 82PF, +5%, -5%, 50V-DC
C137	2113944C43	CAPACITOR, CHIP, 82PF, +5%, -5%, 50V-DC
C138	2113944C43	CAPACITOR, CHIP, 82PF, +5%, -5%, 50V-DC
C139	2113944C43	CAPACITOR, CHIP, 82PF, +5%, -5%, 50V-DC
C140	2113945L17	CAPACITOR, FIXED, 470PF, +5%, -5%, 50V-DC
C141	2113945L17	CAPACITOR, FIXED, 470PF, +5%, -5%, 50V-DC
C142	2113945L17	CAPACITOR, FIXED, 470PF, +5%, -5%, 50V-DC
C143	2313960G32	CAPACITOR, FIXED, 10UF, +10%, -10%, 35V-DC,
C145	2113945L17	CAPACITOR, FIXED, 470PF, +5%, -5%, 50V-DC
C202	2113928J08	CAP CERAMIC CHIP 10.0UF

Reference	Motorola PN	Value
C203	2113928H09	CAPACITOR, CHIP, 1uF, +10, -10,
C303	2113945L17	CAPACITOR, FIXED, 470PF, +5%, -5%, 50V-DC
C304	2113945L17	CAPACITOR, FIXED, 470PF, +5%, -5%, 50V-DC
C305	2113928H09	CAPACITOR, CHIP, 1uF, +10, -10, 10
C306	2113928H09	CAPACITOR, CHIP, 1uF, +10, -10, 10
C307	2113928H02	CAPACITOR, CHIP, .22UF, +10%, -10%, 10V-DC
C308	2113928H02	CAPACITOR, CHIP, .22UF, +10%, -10%, 10V-DC
C309	2113945C31	CAPACITOR, FIXED, .1UF, +10%, -10%, 50V-DC,
C401	2113945C31	CAPACITOR, FIXED, .1UF, +10%, -10%, 50V-DC,
C402	2113945C31	CAPACITOR, FIXED, .1UF, +10%, -10%, 50V-DC,
C403	2113945G91	CAPACITOR, FIXED, .1UF, +10%, -10%, 50V-DC, 0805, X7R, -
C404	2113945G91	CAPACITOR, FIXED, .1UF, +10%, -10%, 50V-DC, 0805, X7R, -
C405	2113945C31	CAPACITOR, FIXED, .1UF, +10%, -10%, 50V-DC,
C406	2113945G91	CAPACITOR, FIXED, .1UF, +10%, -10%, 50V-DC, 0805, X7R, -
C407	2113945G91	CAPACITOR, FIXED, .1UF, +10%, -10%, 50V-DC, 0805, X7R, -
C501	2313960F30	CAPACITOR, FIXED, 47UF, +10%, -10%, 10V-DC,
C502	2113945C31	CAPACITOR, FIXED, .1UF, +10%, -10%, 50V-DC,
C503	2113945L17	CAPACITOR, FIXED, 470PF, +5%, -5%, 50V-DC
C505	2113945C18	CAPACITOR, FIXED, .012UF, +10%, -10%, 50V-DC
C506	2113928J08	CAP CERAMIC CHIP 10.0UF
C507	2113945C31	CAPACITOR, FIXED, .1UF, +10%, -10%, 50V-DC,
C508	2113945C31	CAPACITOR, FIXED, .1UF, +10%, -10%, 50V-DC,
C601	2113945L17	CAPACITOR, FIXED, 470PF, +5%, -5%, 50V-DC
C602	2113945C31	CAPACITOR, FIXED, .1UF, +10%, -10%, 50V-DC,
C603	2113945C31	CAPACITOR, FIXED, .1UF, +10%, -10%, 50V-DC,
C604	2113945L17	CAPACITOR, FIXED, 470PF, +5%, -5%, 50V-DC
C605	2113945C31	CAPACITOR, FIXED, .1UF, +10%, -10%, 50V-DC,
C606	2113945C31	CAPACITOR, FIXED, .1UF, +10%, -10%, 50V-DC,
C607	2311049A08	CAPACITOR, FIXED, 1UF, +10%, -10%, 35V-DC

Reference	Motorola PN	Value
C608	2113928H09	CAPACITOR, CHIP, 1uF, +10, -10, 10,
C610	2113945C31	CAPACITOR, FIXED, .1UF, +10%, -10%, 50V-DC,
C611	2113945C31	CAPACITOR, FIXED, .1UF, +10%, -10%, 50V-DC,
C612	2313960G32	CAPACITOR, FIXED, 10UF, +10%, -10%, 35V-D
C613	2113928J08	CAP CERAMIC CHIP 10.0UF
C614	2113945L17	CAPACITOR, FIXED, 470PF, +5%, -5%, 50V-DC
C615	2113944C43	CAPACITOR, CHIP, 82PF, +5%, -5%, 50V-DC
C616	2113945L17	CAPACITOR, FIXED, 470PF, +5%, -5%, 50V-DC
D101	4813978C02	DIODE ARRAY, SWITCHING, SM, SOT-23, 200MA, 70V, .225W, 2
D102	4813978C02	DIODE ARRAY, SWITCHING, SM, SOT-23, 200MA, 70V, .225W, 2
F101	6503566D15	FUSE, THIN FILM, 2A, 32V,
J1001	0916162H02	CONNECTOR, FEMALE, 12CONT, 12 POS, FLEX CONNECTOR, SIDE ENTRY
J1003	0966512A01	CONNECTOR, BOARD TO BOARD, 0 ROW, RECEPTACLE, 20CONT, 2.54MM,
J1005	0905505Y04	CONNECTOR, FLEX CIRCUIT, 1 ROW, FEMALE, 40CONT, .5MM
J1022	0905505Y04	CONNECTOR, FLEX CIRCUIT, 1 ROW, FEMALE, 40CONT, .5MM,
Q101	4813973M07	TRANSISTOR, BIP GENERAL PURPOSE SMALL SIGNAL
Q102	4813973A42	TRANSISTOR, BIP GENERAL PURPOSE SMALL SIGNAL
Q103	4813973A87	TRANSISTOR, BIP GENERAL PURPOSE SMALL SIGNAL
Q401	4813973A87	TRANSISTOR, BIP GENERAL PURPOSE SMALL SIGNAL
Q501	4813973A42	TRANSISTOR, BIP GENERAL PURPOSE SMALL SIGNAL
Q503	4813971A08	TRANSISTOR, BIP GENERAL PURPOSE POWER, BIPOLAR
Q504	4813973A42	TRANSISTOR, BIP GENERAL PURPOSE SMALL SIGNAL
Q601	4813973A13	TRANSISTOR, BIP GENERAL PURPOSE SMALL SIGNAL
Q602	4813973A13	TRANSISTOR, BIP GENERAL PURPOSE SMALL SIGNAL
Q603	4813973M07	TRANSISTOR, BIP GENERAL PURPOSE SMALL SIGNAL
Q604	4813973A13	TRANSISTOR, BIP GENERAL PURPOSE SMALL SIGNAL
R101	0613952G67	RESISTOR, METAL FILM, 0OHM, 1%, .1W,
R102	0613952J17	RESISTOR, METAL FILM, 47KOHM, 5%, .1W,
R103	0613952J01	RESISTOR, METAL FILM, 10KOHM, 5%, .1W,

Reference	Motorola PN	Value
R104	0613952J17	RESISTOR,METAL FILM,47KOHM,5%,.1W,
R105	0613952G67	RESISTOR,METAL FILM,0OHM,1%,.1W,
R106	0613952G67	RESISTOR,METAL FILM,0OHM,1%,.1W,SM,
R107	0613952G67	RESISTOR,METAL FILM,0OHM,1%,.1W,SM,
R108	0613952H25	RESISTOR,METAL FILM,10OHM,5%,.1W,
R109	0613952H89	RESISTOR,METAL FILM,4.7KOHM,5%,.1W,
R110	0613952G67	RESISTOR,METAL FILM,0OHM,1%,.1W,
R111	0613952J17	RESISTOR,METAL FILM,47KOHM,5%,.1W,
R112	0613952J01	RESISTOR,METAL FILM,10KOHM,5%,.1W,
R113	0613952H95	RESISTOR,METAL FILM,8.2KOHM,5%,.1W,
R114	0613952J17	RESISTOR,METAL FILM,47KOHM,5%,.1W,
R115	0613952H89	RESISTOR,METAL FILM,4.7KOHM,5%,.1W,
R201	0613952H89	RESISTOR,METAL FILM,4.7KOHM,5%,.1W,
R202	0613952H89	RESISTOR,METAL FILM,4.7KOHM,5%,.1W,
R205	0613952G67	RESISTOR,METAL FILM,0OHM,1%,.1W,
R206	0613952G67	RESISTOR,METAL FILM,0OHM,1%,.1W,
R208	0614033G66	RESISTOR,METAL FILM,47KOHM,.1%,.063W,
R209	0614033G66	RESISTOR,METAL FILM,47KOHM,.1%,.063W,
R210	0614033G66	RESISTOR,METAL FILM,47KOHM,.1%,.063W,
R211	0614033G66	RESISTOR,METAL FILM,47KOHM,.1%,.063W,
R212	0613952G67	RESISTOR,METAL FILM,0OHM,1%,.1W,
R213	0613952G67	RESISTOR,METAL FILM,0OHM,1%,.1W,
R214	0614033G66	RESISTOR,METAL FILM,47KOHM,.1%,.063W,
R215	0614033G66	RESISTOR,METAL FILM,47KOHM,.1%,.063W,
R216	0614033G66	RESISTOR,METAL FILM,47KOHM,.1%,.063W,
R217	0614033G66	RESISTOR,METAL FILM,47KOHM,.1%,.063W,
R218	0614033G66	RESISTOR,METAL FILM,47KOHM,.1%,.063W,
R219	0614033G66	RESISTOR,METAL FILM,47KOHM,.1%,.063W,
R220	0614033E58	RESISTOR,METAL FILM,392OHM,.1%,.063W,
R221	0614033E58	RESISTOR,METAL FILM,392OHM,.1%,.063W,

Reference	Motorola PN	Value
R222	0613952G67	RESISTOR,METAL FILM,0OHM,1%,.1W,
R223	0613952G67	RESISTOR,METAL FILM,0OHM,1%,.1W,
R301	0613952J01	RESISTOR,METAL FILM,10KOHM,5%,.1W,
R302	0613952J01	RESISTOR,METAL FILM,10KOHM,5%,.1W,
R303	0613952J01	RESISTOR,METAL FILM,10KOHM,5%,.1W,
R304	0613952J01	RESISTOR,METAL FILM,10KOHM,5%,.1W,
R305	0613952H61	RESISTOR,METAL FILM,330OHM,5%,.1W,
R306	0613952H61	RESISTOR,METAL FILM,330OHM,5%,.1W,
R307	0613952F01	RESISTOR,METAL FILM,100KOHM,1%,.1W,
R308	0613952F01	RESISTOR,METAL FILM,100KOHM,1%,.1W,
R309	0613952J01	RESISTOR,METAL FILM,10KOHM,5%,.1W,
R310	0613952J01	RESISTOR,METAL FILM,10KOHM,5%,.1W,
R311	0613952J01	RESISTOR,METAL FILM,10KOHM,5%,.1W,
R312	0613952J01	RESISTOR,METAL FILM,10KOHM,5%,.1W,
R313	0613952F01	RESISTOR,METAL FILM,100KOHM,1%,.1W,
R314	0613952F01	RESISTOR,METAL FILM,100KOHM,1%,.1W,
R315	0613952H45	RESISTOR,METAL FILM,68OHM,5%,.1W,
R316	0613952H45	RESISTOR,METAL FILM,68OHM,5%,.1W,
R317	0613952H65	RESISTOR,METAL FILM,470OHM,5%,.1W,
R318	0613952H77	RESISTOR,METAL FILM,1.5KOHM,5%,.1W,
R319	0613952H81	RESISTOR,METAL FILM,2.2KOHM,5%,.1W,
R320	0613952H37	RESISTOR,METAL FILM,330OHM,5%,.1W,
R321	0613952H37	RESISTOR,METAL FILM,330OHM,5%,.1W,
R322	0613952H37	RESISTOR,METAL FILM,330OHM,5%,.1W,
R323	0613952H37	RESISTOR,METAL FILM,330OHM,5%,.1W,
R324	0613952H53	RESISTOR,METAL FILM,150OHM,5%,.1W,
R325	0613952H53	RESISTOR,METAL FILM,150OHM,5%,.1W,
R401	0613952J17	RESISTOR,METAL FILM,47KOHM,5%,.1W,
R402	0613952J17	RESISTOR,METAL FILM,47KOHM,5%,.1W,
R501	0613952E10	RESISTOR,METAL FILM,12.4KOHM,1%,.1W,
R502	0613952G67	RESISTOR,METAL FILM,0OHM,1%,.1W,

Reference	Motorola PN	Value
R508	0613952E88	RESISTOR,METAL FILM,80.6KOHM,1%,.1W,
R509	0613952H25	RESISTOR,METAL FILM,10OHM,5%,.1W,
R510	0613952E10	RESISTOR,METAL FILM,12.4KOHM,1%,.1W,
R511	0613952H89	RESISTOR,METAL FILM,4.7KOHM,5%,.1W,
R512	0613952H89	RESISTOR,METAL FILM,4.7KOHM,5%,.1W,
R518	0613952J01	RESISTOR,METAL FILM,10KOHM,5%,.1W,
R519	0613952H81	RESISTOR,METAL FILM,2.2KOHM,5%,.1W,
R520	0613952H81	RESISTOR,METAL FILM,2.2KOHM,5%,.1W,
R601	0613952H89	RESISTOR,METAL FILM,4.7KOHM,5%,.1W,
R602	0613952H89	RESISTOR,METAL FILM,4.7KOHM,5%,.1W,
R603	0613952H89	RESISTOR,METAL FILM,4.7KOHM,5%,.1W,
R604	0613952J01	RESISTOR,METAL FILM,10KOHM,5%,.1W,
R605	0613952H81	RESISTOR,METAL FILM,2.2KOHM,5%,.1W,
R606	0613952H89	RESISTOR,METAL FILM,4.7KOHM,5%,.1W,
R607	0613952J01	RESISTOR,METAL FILM,10KOHM,5%,.1W,
R608	0613952J01	RESISTOR,METAL FILM,10KOHM,5%,.1W,
R609	0613952H81	RESISTOR,METAL FILM,2.2KOHM,5%,.1W,
R610	0613952H89	RESISTOR,METAL FILM,4.7KOHM,5%,.1W,
R611	0613952J01	RESISTOR,METAL FILM,10KOHM,5%,.1W,
R612	0613952H81	RESISTOR,METAL FILM,2.2KOHM,5%,.1W,
R613	0613952J01	RESISTOR,METAL FILM,10KOHM,5%,.1W,
R614	0613952H81	RESISTOR,METAL FILM,2.2KOHM,5%,.1W,
R615	0613952H89	RESISTOR,METAL FILM,4.7KOHM,5%,.1W,
R616	0613952J01	RESISTOR,METAL FILM,10KOHM,5%,.1W,
R617	0613952H92	RESISTOR,METAL FILM,6.2KOHM,5%,.1W,
R618	0613952E10	RESISTOR,METAL FILM,12.4KOHM,1%,.1W,
R619	0613952J01	RESISTOR,METAL FILM,10KOHM,5%,.1W,

Reference	Motorola PN	Value
R620	0613952J01	RESISTOR,METAL FILM,10KOHM,5%,.1W,
R623	0613952H67	CER CHIP RES 560 OHM 5% 0603
R624	0613952H49	RESISTOR,METAL FILM,100OHM,5%,.1W,
R625	0613952J01	RESISTOR,METAL FILM,10KOHM,5%,.1W,
U101	5186988J61	IC,TRANSCEIVER,5 DRIVER 3 RECEIVER,EIA/TIA-232 AND V.28/V.24,MAX3238,SM,SSOP28,+/-15KVESD-PROTECTED/I/O AND LOGIC PINS ,5.5
U201	5114016A18	IC,OPERATIONAL AMPLIFIER,4PER PKG,GENERAL PURPOSE,SOIC,PB FREE
U301	5114016A18	IC,OPERATIONAL AMPLIFIER,4PER PKG,GENERAL PURPOSE,SOIC,PB FREE
U302	5187547J01	LINE DRIVER,DIFFERENTIAL,SN65LBC179,SM,SOIC8
U401	5166552A01	IC,CONTROL- LER,MAX3100,QSOP,QSOP16,3.6864MH Z,0BITS,PB-FREE
U402	4886061B02	RESONATOR,CERAMIC,3.68MHZ
U403	5114009A35	IC,TRANSCEIVER,8PER PKG,74AC244,3-STATE,SM,SOIC20,PB-FREE
U404	5188462T01	IC,DRIVER/RECEIVER,RS232 TRANS- CEIVER,232,2PER PKG,TSSOP20,RS232 TRANCIVER MAXIM 3232 LEADFREE
U501	5114014M39	IC,LINEAR VOLTAGE REGULA- TOR,FIXED,3V,100MA,SM,SOIC8,PB-FREE
U503	5114014A22	IC,LINEAR VOLTAGE REGULA- TOR,FIXED,5V,100MA,SM,SOIC8,PB-FREE
U601	5114009A07	IC,AND,74AC08,4PER PKG,SOIC14,6
U602	5114006A02	IC,COMPARA- TOR,LM2903,SM,SOIC8,2PER PKG,PB-FREE
U603	5109781E79	IC SW ANAL SPDT MAX4544EUT
VR101	4813977M11	DIODE,ZENER,MBZ5232,SM,SOT- 23,5.6V,10MA,.
VR102	4813977M36	DIODE,ZENER,MBZ5257,SM,SOT- 23,33V,10MA,.
VR103	4813979P10	DIODE ARRAY,TRANSIENT PROTEC- TION,SM,SOT-457,5.6V,.225W,ZENER,
VR104	4813979C11	DIODE,SUPPRESSOR,SOT-26/SC- 74,15V,.
VR105	4813977M36	DIODE,ZENER,MBZ5257,SM,SOT- 23,33V,10MA,.
VR106	4813979C11	DIODE,SUPPRESSOR,SOT-26/SC- 74,15V,.
VR108	4813979C11	DIODE,SUPPRESSOR,SOT-26/SC- 74,15V,.

Reference	Motorola PN	Value
VR109	4813977M36	DIODE,ZENER,MBZ5257,SM,SOT-23,33V,10MA,.
VR110	4813977M36	DIODE,ZENER,MBZ5257,SM,SOT-23,33V,10MA,.
VR111	4813977M36	DIODE,ZENER,MBZ5257,SM,SOT-23,33V,10MA,.
VR112	4813977M36	DIODE,ZENER,MBZ5257,SM,SOT-23,33V,10MA,.
VR113	4813977M36	DIODE,ZENER,MBZ5257,SM,SOT-23,33V,10MA,.

Exp. Head (PCB: 8464300B06_A) Conn. Board

Reference	Motorola PN	Value
J0101	2864287B01	CONN_J
J0102	0964329B01	CONN_J
J0103	0964328B01	CONN_J
J0104	0905505Y04	TELCO10PIN

Remote Mount Head (PCB 8471016L02)

Reference	Motorola PN	Value
C201	2113945C18	CAP .012uF
C202	2113928J08	CAP 10uF
C203	2113945C31	CAP 0.1uF
C204	2113945C31	CAP 0.1uF
C206	2311049A08	CAPP 1uF
C301	2113928J08	CAP 10uF
C302	2113945L17	CAP 470pF
C303	2113945L17	CAP 470pF
C304	2113945L17	CAP 470pF
C305	2113945L17	CAP 470pF
C306	2113945L17	CAP 470pF
C307	2113945L17	CAP 470pF
C308	2113945L17	CAP 470pF
C309	2113945L17	CAP 470pF
C310	2113944C43	CAP 82pF
C311	2113944C43	CAP 82pF
C313	2113928J08	CAP 10uF
C314	2113944C43	CAP 82pF
F300	6503566D15	FUSE undefined
J301	0916162H02	CONN_J undefined
J302	2864287B01	CONN_P undefined
Q101	4813973A42	MUN2213 undefined
R101	0613952E10	RES 12.4K
R102	0613952G67	RES 0
R201	0613952E88	RES 80.6K
R202	0613952E10	RES 12.4K

Reference	Motorola PN	Value
R203	0613952H89	RES 4.7K
R204	0613952H89	RES 4.7K
R301	0614033G66	RES 47.5K
R302	0614033G66	RES 47.5K
R303	0613952G67	RES 0
R304	0613952G67	RES 0
R306	0614033G66	RES 47.5K
R307	0614033G66	RES 47.5K
R308	0613952G67	RES 0
R309	0613952G67	RES 0
R310	0614033G66	RES 47.5K
R311	0614033G66	RES 47.5K
R312	0614033G66	RES 47.5K
R313	0614033G66	RES 47.5K
R314	0614033E58	RES 392
R315	0614033E58	RES 392
R316	0614033G66	RES 47.5K
R317	0614033G66	RES 47.5K
R318	0613952G67	RES 0
R321	0613952E10	RES 12.4K
R322	0613952H92	RES 6.2K
R323	0613952H89	RES 4.7K
R324	0613952H89	RES 4.7K
R325	0613952E10	RES 12.4K
R326	0613952E10	RES 12.4K
U201	5114014A22	LP2951CD undefined
U202	5114016A18	MC3403 undefined
VR301	4813977M36	MMBZ5257BLT1G undefined
VR302	4813977M36	MMBZ5257BLT1G undefined
VR303	4813979C11	MMQA20VT1 unde- fined
VR304	4813979P10	MMQA5V6T1 unde- fined

Remote Mount Back Housing(PCB 84966583A01)

Reference	Motorola PN	Value
C101	2113945A05	CAP, 470pF
C102	2113945A05	CAP, 470pF
C103	2113945A05	CAP, 470pF
C104	2113945A05	CAP, 470pF
C105	2113944A31	CAP, 33pF
C106	2113945A05	CAP, 470pF
C107	2113945A05	CAP, 470pF
C108	2113944A31	CAP, 33pF

Reference	Motorola PN	Value
C201	2113928H09	CAP, 1uF
C202	2113946B04	CAP, 0.1uF
C203	2113946B04	CAP, 0.1uF
C204	2113928H09	CAP, 1uF
C205	2113946A01	CAP, .015uF
C206	2113928H09	CAP, 1uF
C207	2113956C37	CAP, 10uF
C208	2113946B04	CAP, 0.1uF
C209	2113956C37	CAP, 10uF
C210	2113956C37	CAP, 10uF
C211	2113946B04	CAP, 0.1uF
C212	2113956C37	CAP, 10uF
C213	2113956C37	CAP, 10uF
C214	2113946B04	CAP, 0.1uF
C215	2113946B04	CAP, 0.1uF
C216	2113956C37	CAP, 10uF
C217	2313960G32	CAPP, 10uF
C301	2113946B04	CAP, 0.1uF
C302	2113945G91	CAP, 0.1uF
C303	2113945G91	CAP, 0.1uF
C304	2113946B04	CAP, 0.1uF
C305	2113946B04	CAP, 0.1uF
C306	2113946B04	CAP, 0.1uF
C307	2113945G91	CAP, 0.1uF
C308	2113945G91	CAP, 0.1uF
C309	2113944A31	CAP, 33pF
C310	2113944A31	CAP, 33pF
C311	2113956C37	CAP, 10uF
C312	2113946B04	CAP, 0.1uF
C313	2113946B04	CAP, 0.1uF
C314	2113956C37	CAP, 10uF
C315	2113946B04	CAP, 0.1uF
C316	2113945A05	CAP, 470pF
C317	2113946B04	CAP, 0.1uF
C401	2113945A05	CAP, 470pF
C402	2113945A05	CAP, 470pF
C403	2113944A31	CAP, 33pF
C404	2113944A31	CAP, 33pF
C405	2113945A05	CAP, 470pF
C406	2113945A05	CAP, 470pF
C407	2113944A31	CAP, 33pF
C408	2113944A31	CAP, 33pF
C409	2113944A31	CAP, 33pF
C410	2113944A31	CAP, 33pF
C411	2113944A31	CAP, 33pF
C412	2113944A31	CAP, 33pF
C413	2113944A31	CAP, 33pF

Reference	Motorola PN	Value
C414	2113945A05	CAP, 470pF
C415	2113944A31	CAP, 33pF
C416	2113945A05	CAP, 470pF
C417	2113945A05	CAP, 470pF
C418	2113945A05	CAP, 470pF
C419	2113945A05	CAP, 470pF
C420	2113945A05	CAP, 470pF
C421	2113944A31	CAP, 33pF
C422	2113944A31	CAP, 33pF
C423	2113945A05	CAP, 470pF
C424	2113945A05	CAP, 470pF
C425	2113944A31	CAP, 33pF
C426	2113944A31	CAP, 33pF
C427	2113945A05	CAP, 470pF
C428	2113945A05	CAP, 470pF
C429	2113945A05	CAP, 470pF
C430	2113945A05	CAP, 470pF
C431	2113944A31	CAP, 33pF
C432	2113944A31	CAP, 33pF
C433	2113944A31	CAP, 33pF
C434	2113945A05	CAP, 470pF
C435	2113944A31	CAP, 33pF
C436	2113945A05	CAP, 470pF
C437	2113945A05	CAP, 470pF
C438	2113945A05	CAP, 470pF
C439	2113945A05	CAP, 470pF
C440	2113944A31	CAP, 33pF
C441	2113944A31	CAP, 33pF
C442	2113944A31	CAP, 33pF
C443	2113944A31	CAP, 33pF
C444	2113944A31	CAP, 33pF
C445	2113944A31	CAP, 33pF
C446	2113944A31	CAP, 33pF
C447	2113944A31	CAP, 33pF
C448	2113944A31	CAP, 33pF
C449	2113944A31	CAP, 33pF
C450	2113945A05	CAP, 470pF
C451	2113944A31	CAP, 33pF
C452	2113945A05	CAP, 470pF
C453	2113956C37	CAP, 10uF
C454	2113946B04	CAP, 0.1uF
C455	2113946B04	CAP, 0.1uF
C501	2113946B04	CAP, 0.1uF
C502	2113945G91	CAP, 0.1uF
C503	2113946B04	CAP, 0.1uF
C504	2113946B04	CAP, 0.1uF
C505	2113946B04	CAP, 0.1uF

Reference	Motorola PN	Value
C506	2113946B04	CAP, 0.1uF
D301	4866544A01	SR05
D401	4866544A01	SR05
D402	4813978C02	MMBD6100
J104	0971065L01	in CONN_J
J105	2871067L01	CONN_P
P101	2864287B01	CONN_P
P201	2815162H01	n CONN_P
Q201	4813973A81	MUN5311DW1T1
Q301	4805921T28	FMG8A
Q302	4815272H01	EMD9FT2R
Q305	4805921T28	FMG8A
Q306	5166540A01	FDC6330L
Q307	5166540A01	FDC6330L
Q308	4805921T28	FMG8A
Q401	4813973A81	MUN5311DW1T1
Q501	4813973A81	MUN5311DW1T1
Q502	4816147H01	BCV49
Q503	4813973A81	MUN5311DW1T1
R102	0613952R01	RES, 10K
R103	0613952Q89	RES, 4.7K
R201	0614033G66	RES, 47.5K
R202	0613952R66	RES, 0
R203	0613952R66	RES, 0
R204	0614033G66	RES, 47.5K
R205	0614033G66	RES, 47.5K
R206	0614033G66	RES, 47.5K
R207	0614033G66	RES, 47.5K
R208	0614033G66	RES, 47.5K
R209	0614033G66	RES, 47.5K
R210	0614033G66	RES, 47.5K
R211	0614033G66	RES, 47.5K
R212	0614033G66	RES, 47.5K
R213	0613952R01	RES, 10K
R214	0613952Q49	RES, 100
R215	0614033E58	RES, 392
R216	0613952Q67	RES, 560
R217	0613952R01	RES, 10K
R218	0614033E58	RES, 392
R220	0613952R01	RES, 10K
R221	0613952R66	RES, 0
R222	0613952R05	RES, 15K
R223	0613952R05	RES, 15K
R225	0613952N62	RES, 43.2K
R226	0613952R05	RES, 15K
R227	0613952M81	RES, 6.81K
R228	0613952Q89	RES, 4.7K

Reference	Motorola PN	Value
R231	0613952Q89	RES, 4.7K
R232	0613952R01	RES, 10K
R233	0613952R01	RES, 10K
R234	0613952Q49	RES, 100
R235	0613952R01	RES, 10K
R236	0613952Q49	RES, 100
R237	0613952Q49	RES, 100
R238	0613952Q67	RES, 560
R239	0613952Q67	RES, 560
R240	0613952R25	RES, 100K
R241	0613952R25	RES, 100K
R242	0613952R25	RES, 100K
R243	0613952Q49	RES, 100
R301	0613952Q89	RES, 4.7K
R302	0613952Q73	RES, 1K
R303	0613952Q89	RES, 4.7K
R304	0613952Q73	RES, 1K
R305	0613952Q77	RES, 1.5K
R306	0613952Q37	RES, 33
R311	0613952Q37	RES, 33
R312	0613952R05	RES, 15K
R313	0613952R05	RES, 15K
R315	0613952R01	RES, 10K
R316	0613952R01	RES, 10K
R317	0613952R05	RES, 15K
R318	0613952R01	RES, 10K
R319	0613952R01	RES, 10K
R320	0613952R01	RES, 10K
R321	0613952R01	RES, 10K
R322	0613952R05	RES, 15K
R323	0613952R25	RES, 100K
R324	0613952R25	RES, 100K
R423	0613952R66	RES, 0
R424	0613952R66	RES, 0
R425	0613952Q73	RES, 1K
R426	0613952Q41	RES, 47
R427	0613952R01	RES, 10K
R428	0613952Q89	RES, 4.7K
R429	0613952Q89	RES, 4.7K
R430	0613952R25	RES, 100K
R431	0613952R25	RES, 100K
R501	0613952R05	RES, 15K
R502	0613952Q59	RES, 270
R503	0613952R05	RES, 15K
R504	0613952Q59	RES, 270
R505	0613952R05	RES, 15K
R506	0613952Q59	RES, 270

Reference	Motorola PN	Value
R507	0613952R05	RES, 15K
R508	0613952R25	RES, 100K
R510	0613952Q89	RES, 4.7K
R511	0613952Q89	RES, 4.7K
R512	0613952Q89	RES, 4.7K
R513	0613952Q89	RES, 4.7K
R514	0613952Q59	RES, 270
R515	0613952Q59	RES, 270
R516	0613952Q59	RES, 270
R518	0613952R05	RES, 15K
R519	0613952R01	RES, 10K
R520	0613952R05	RES, 15K
R521	0613952R05	RES, 15K
R522	0613952Q89	RES, 4.7K
R523	0613952Q89	RES, 4.7K
R530	0613952R05	RES, 15K
R531	0613952R05	RES, 15K
R532	0613952R05	RES, 15K
R533	0613952R05	RES, 15K
R534	0613952R05	RES, 15K
R535	0613952R05	RES, 15K
R536	0613952R05	RES, 15K
R537	0613952R05	RES, 15K
R538	0613952R05	RES, 15K
R539	0613952R05	RES, 15K
R540	0613952N51	RES, 33.2K
R541	0613952N51	RES, 33.2K
R542	0613952N51	RES, 33.2K
R547	0613952N51	RES, 33.2K
R548	0613952N51	RES, 33.2K
R549	0613952N51	RES, 33.2K
R550	0613952N51	RES, 33.2K
R551	0613952N51	RES, 33.2K
R552	0613952R05	RES, 15K
R554	0613952R05	RES, 15K
R555	0613952R05	RES, 15K
R556	0613952R05	RES, 15K
R557	0613952R05	RES, 15K
U201	5114016A18	MC3403
U203	5175771A10	MAX4544EUT
U204	5175771A10	MAX4544EUT
U205	5114014A22	LP2951CD
U301	5114007A47	NC7SZ32
U302	5187970L07	ISP1105
U303	5188462T01	MAX3232E
U304	5186311J07	NC7SZ175P6X
U401	5186311J07	NC7SZ175P6X

Reference	Motorola PN	Value
U501	5166555A01	PCA9535BS
U502	5166555A01	PCA9535BS
U503	5114006A03	LM2901
U507	5186311J07	NC7SZ175P6X
VR101	4813977M36	MMBZ5257BLT1G
VR102	4813977M36	MMBZ5257BLT1G
VR103	4813979C11	MMQA20VT1
VR104	4813979C11	MMQA20VT1
VR201	4814026A19	1SMB5931B
VR401	4813979C11	MMQA20VT1
VR402	4813979C11	MMQA20VT1
VR403	4813979P10	MMQA5V6T1
VR405	4813979P10	MMQA5V6T1
VR406	4813979C11	MMQA20VT1

Note: For optimum performance, diodes, transistors and integrated circuits must be ordered by MOTOROLA part numbers.

CHAPTER 9

TROUBLESHOOTING

Section Introduction

General

Troubleshooting faults in the terminal require proper understanding of the different circuitry contained in the terminal. Since the terminal contains a highly integrated system, the software and hardware functions can not be separated easily. Thus, it is also necessary to understand the functioning of different ICs and the role of the software in the operation of the terminal. This service manual includes schematic diagrams, circuit board layouts, block diagrams, and troubleshooting procedures, which help a technician to troubleshoot a malfunctioning circuit and detect a defective component.

NOTE: The CPS has no capability to tune the terminal. Tuning the terminal can only be performed at the factory or at the appropriate Motorola Repair Centre. Components replacement can affect the terminal tuning and must only be performed by the appropriate Motorola Repair Centre.

The terminal is tuned and tested at the factory. The results of the tuning procedures are stored in a special area of the Flash PROM. This information includes tuning and other system parameters. The area of the memory in the terminal where the tuning information is stored is called the "codeplug". A terminal codeplug can be read using the CPS programme.

Test Procedures

This section explains the procedures required to troubleshoot an MTM800 ENH terminal. Whenever possible the terminal should be tested and tuned using the automatic test system PATS before troubleshooting. The PATS result file can provide useful hints to determine the failing circuitry section. Alternatively, the Main Function Test Procedure can be performed to determine where to start troubleshooting. After disassembling the board from the chassis you should check the board visually for bad soldering or damaged components.

Troubleshooting Setup

Some of the troubleshooting procedures require an audio signal input or measurement of the audio at the speaker output. The Test Set RLN4460 provides the correct microphone input and speaker output circuitry. Figure 1 shows the recommended setup for troubleshooting. Figure 2 shows the required connections between the terminal's accessory connector, the Test Set and the Interface Box. The Interface Box GMCN1019_ connects the terminal to the RS232 interface of a PC and is required to control the terminal during troubleshooting.

If the terminal is connected to the power supply and the Interface Box the green LED at the Interface Box should light up only. If the red LED lights up as well toggle the switch at the Interface Box and restart the procedure.

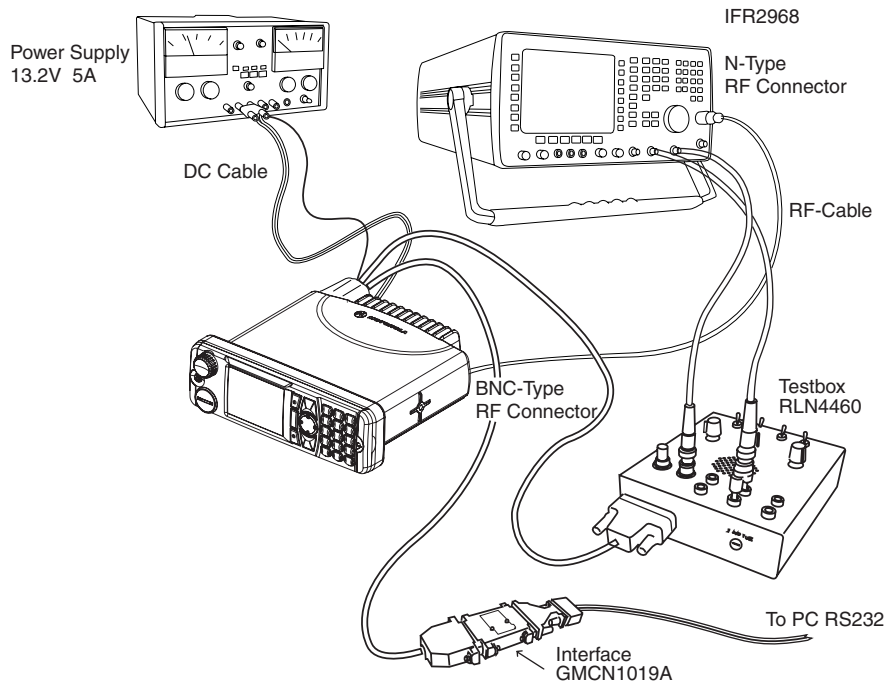

Figure 1 Troubleshooting Setup

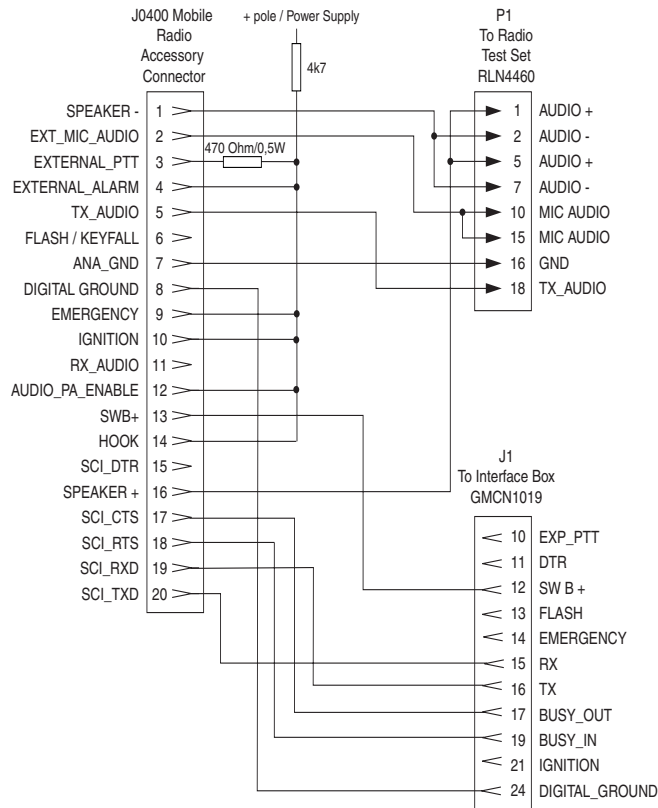

Figure 2 Required Connections (Accessory Connector / Test Set / Interface Box)

WARNING: By proceeding the GPIO test (see following pages) the above connections must be set, otherwise the terminal can be damaged.



For RF levels, which should be measured with a 50 Ohm RF probe, you can use the following circuit.

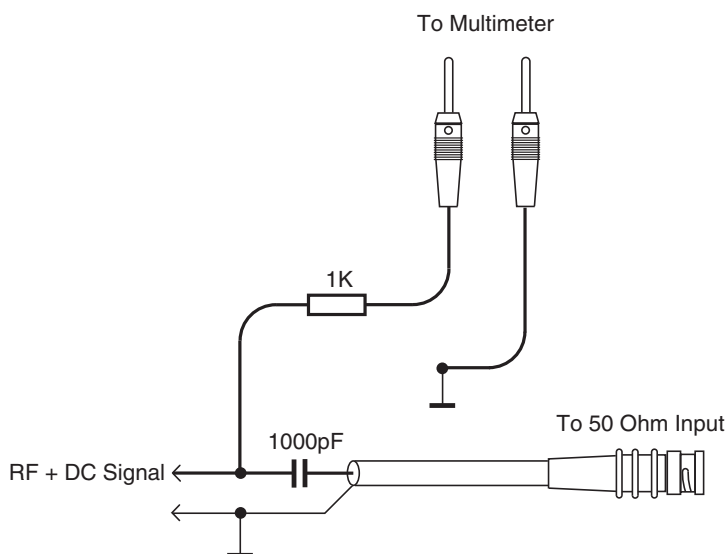

Figure 3 Example for 50 Ohm RF Probe

Troubleshooting Flowcharts

Use the following flowcharts to troubleshoot the terminal.

These flowcharts contain procedures which use the TETRA COM SW application to set the terminal into the appropriate test modes for troubleshooting terminals having digital, receiver, transmitter, or frequency generation failures.

The terminal performs most of the used TETRA COM commands only in test mode. If not in test mode, it ignores these commands.

To enter test mode you must enter the command "TEST_ENTER" in TETRA COM.

After about 18 seconds the TETRA COM screen must show the message "Radio HW is READY" to indicate that the terminal has entered test mode.

Once in test mode, you don't have to use this command again until the test mode is terminated or the terminal performed a reset.

THIS PAGE INTENTIONALLY LEFT BLANK

TROUBLESHOOTING CHARTS

Main Function Test Chart (Sheet 1) >> Startup Procedure <<

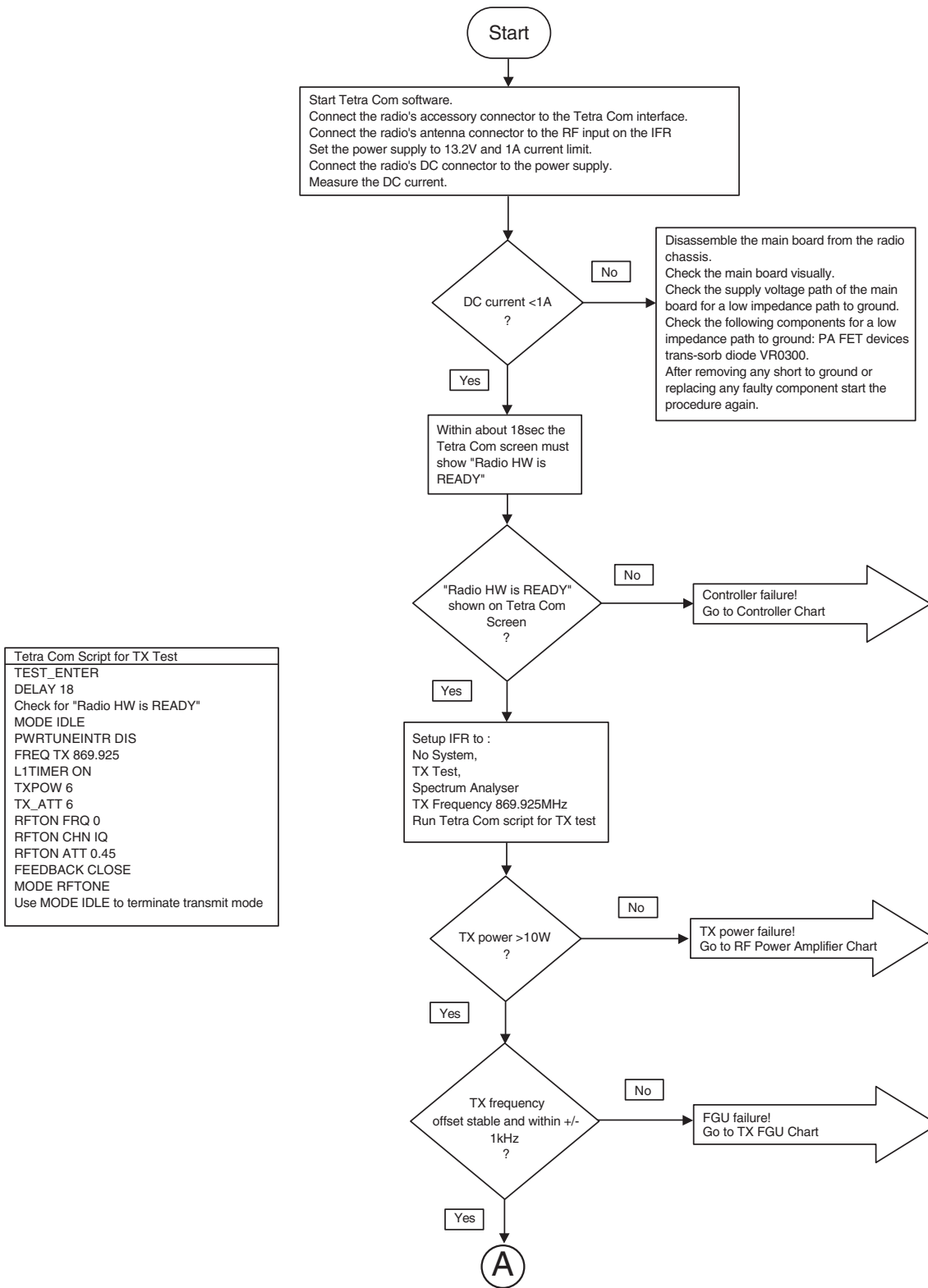

```

Tetra Com Script for TX Test
TEST_ENTER
DELAY 18
Check for "Radio HW is READY"
MODE IDLE
PWRTUNEINTR DIS
FREQ TX 869.925
L1TIMER ON
TXPOW 6
TX_ATT 6
RFTON FRQ 0
RFTON CHN IQ
RFTON ATT 0.45
FEEDBACK CLOSE
MODE RFTONE
Use MODE IDLE to terminate transmit mode
  
```

Main Function Test Chart (Sheet 2)

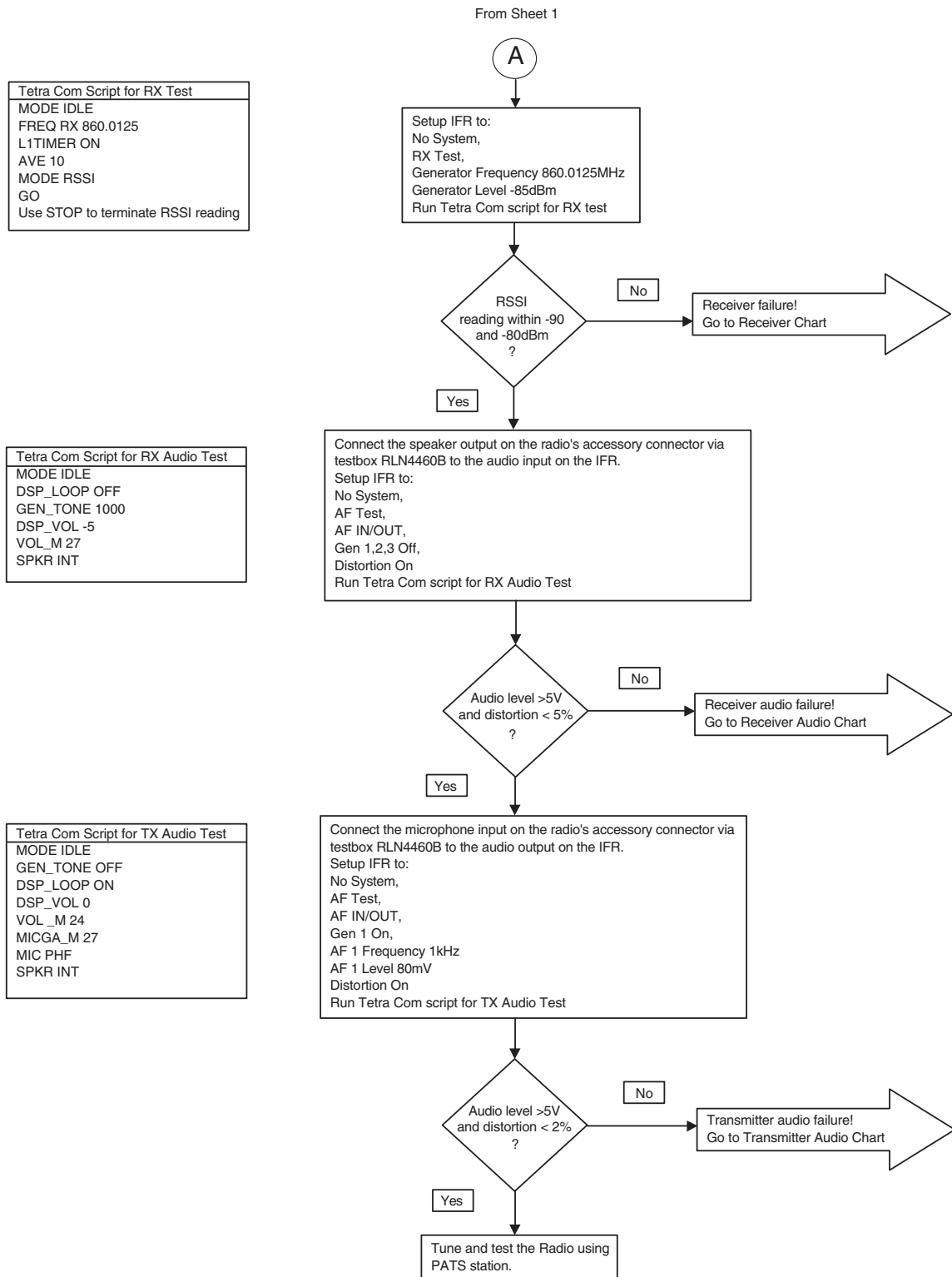

Controller Troubleshooting (Sheet 1)

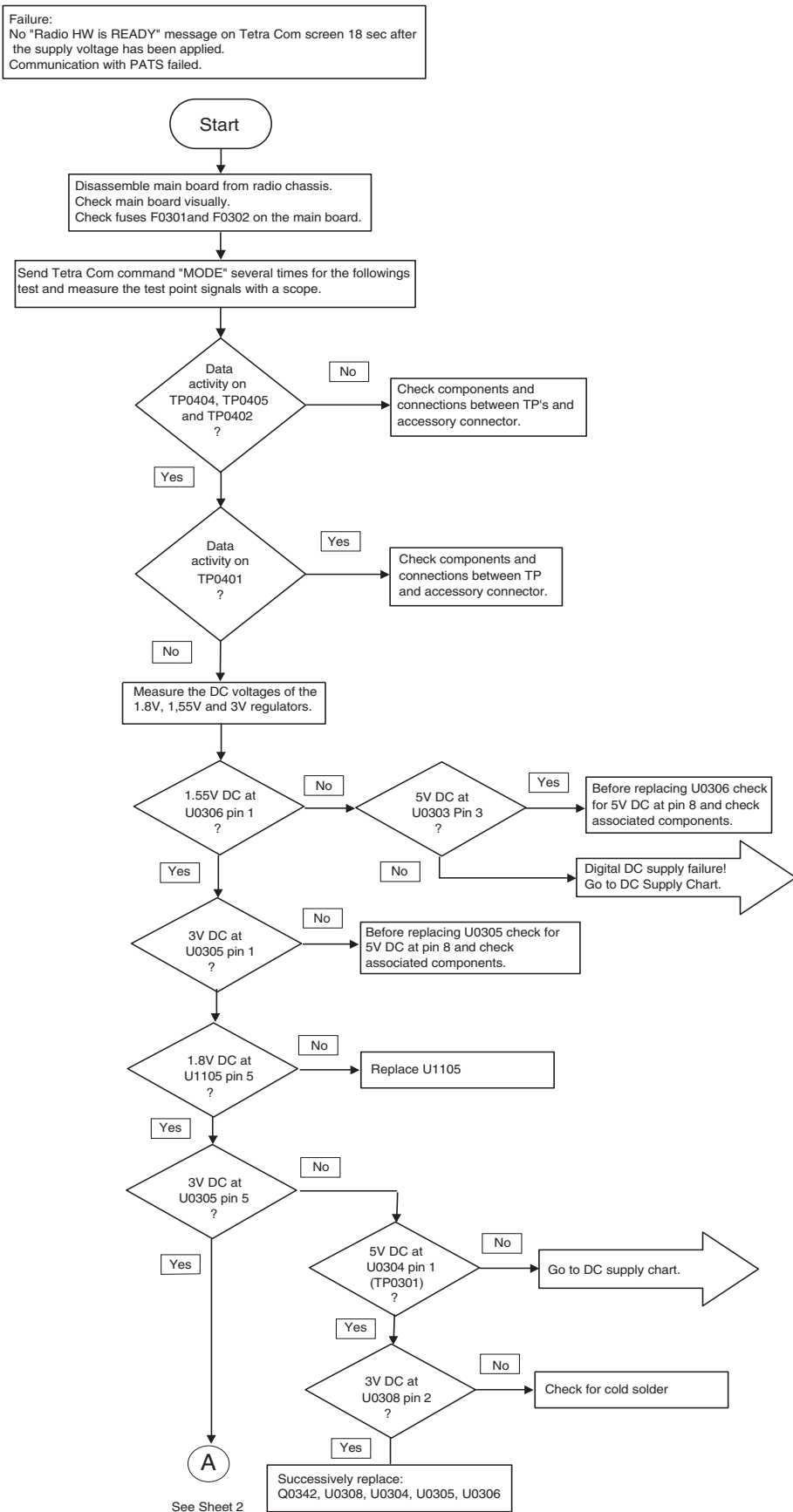

Controller Troubleshooting (Sheet 2)

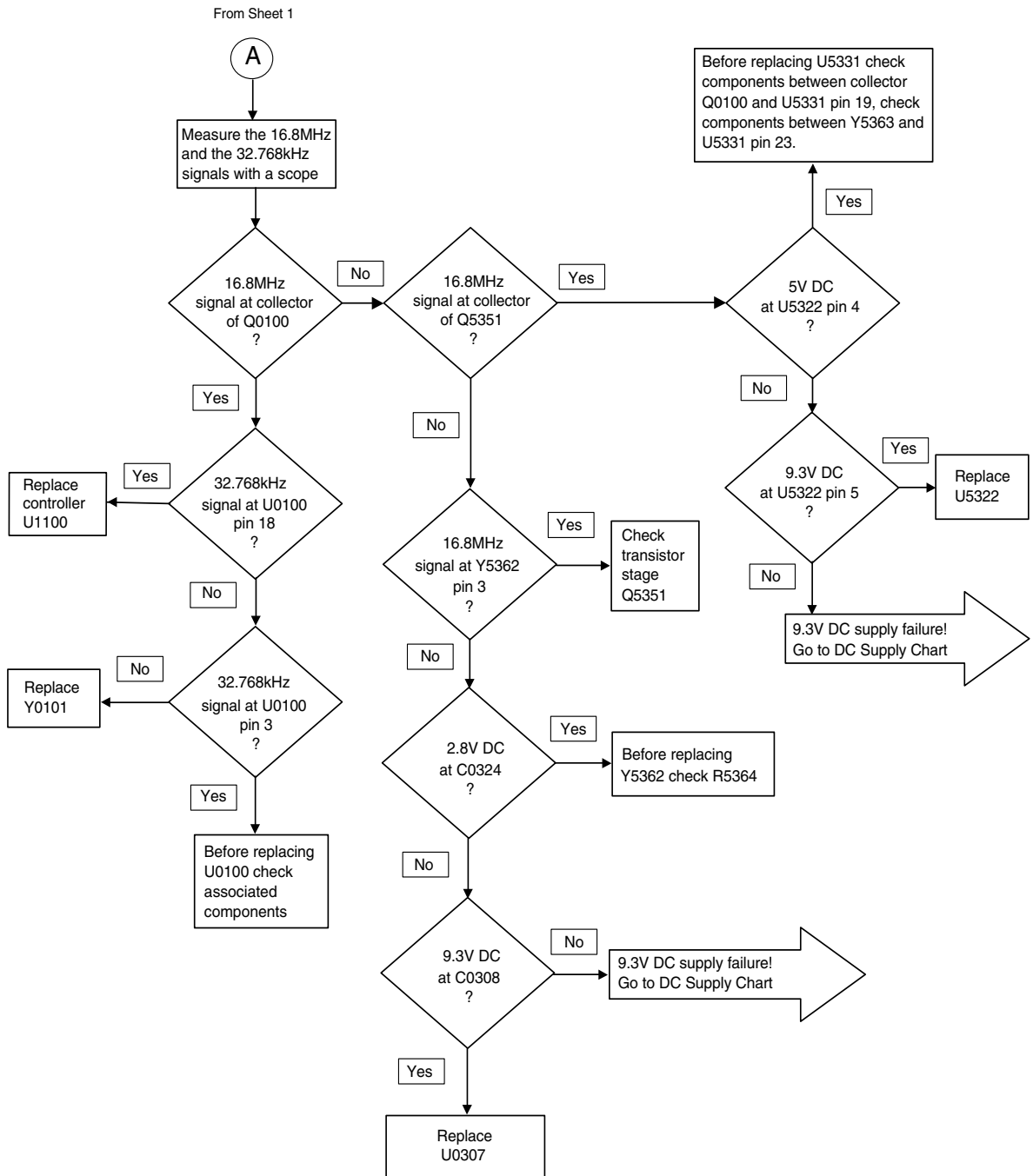

DC Supply Troubleshooting

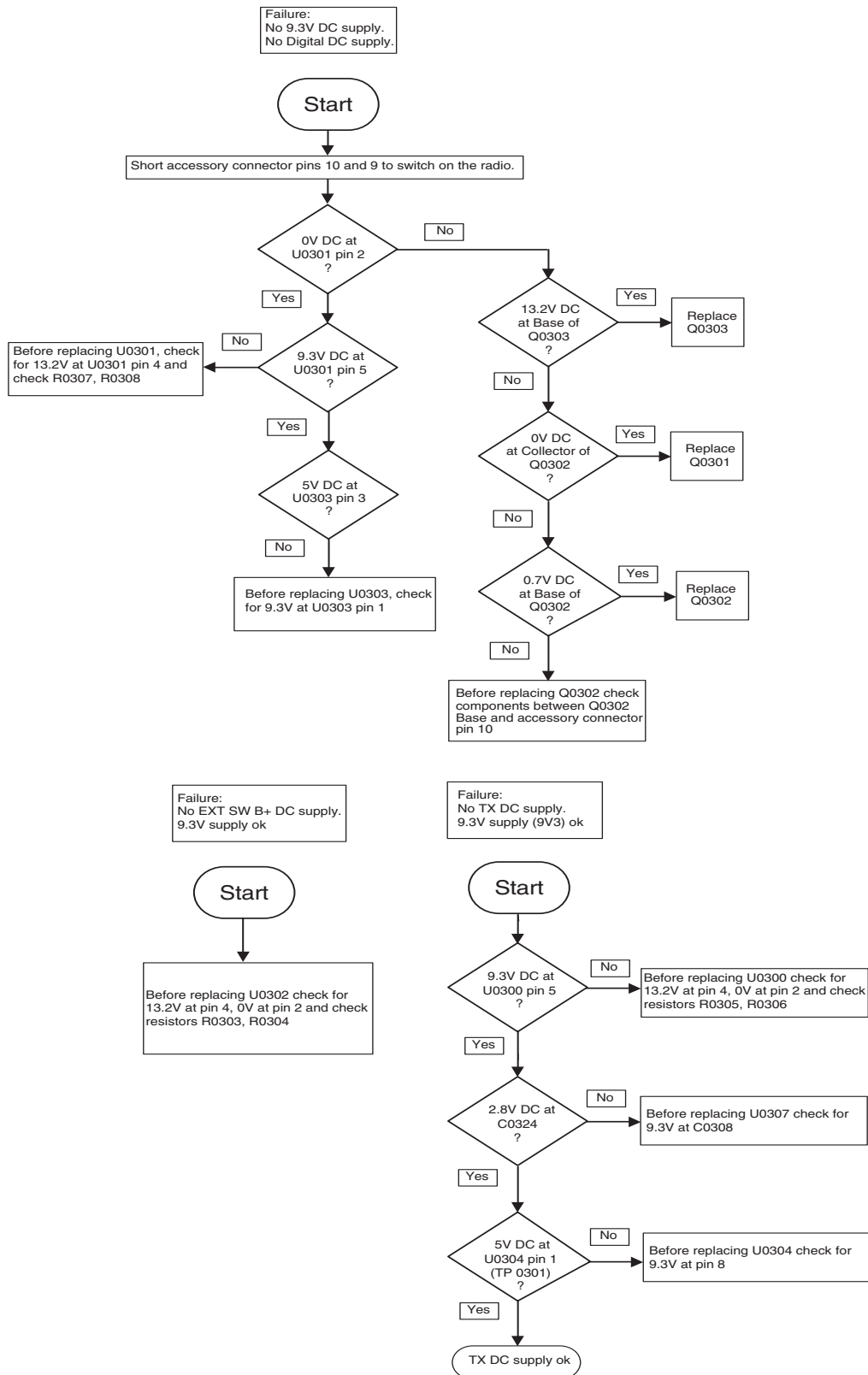

GPIO Troubleshooting



By proceeding the GPIO test, the connections as shown in the Troubleshooting Setup (see previous pages) must be set, otherwise the terminal can be damaged.

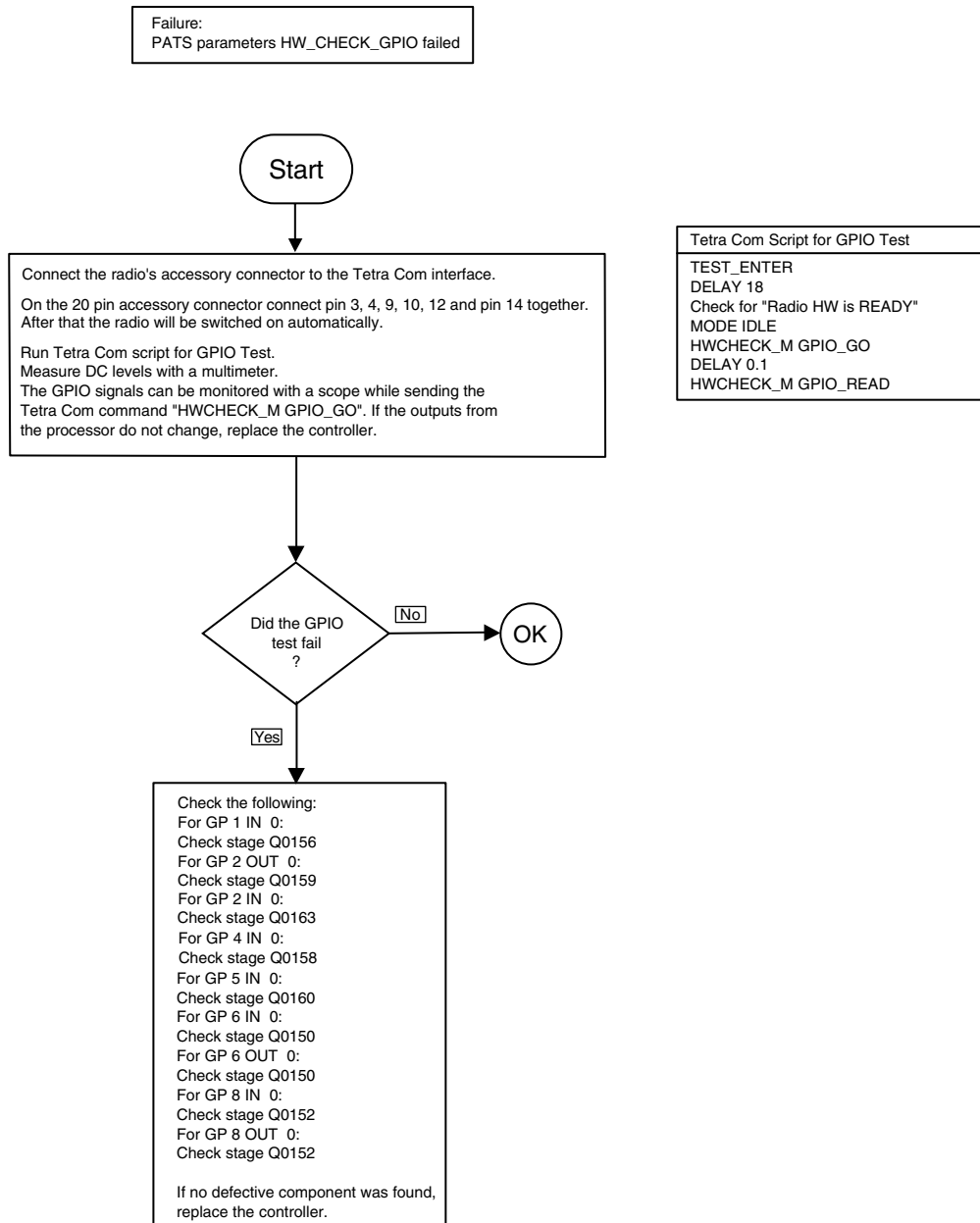

Receiver Audio Troubleshooting

Failure:
 No audio or low audio level at speaker output or handset audio output.
 High distortion at speaker output or handset audio output.
 PATS parameters AUD_LBACK_GAIN or AUD_LBACK_DIST failed.

Start

Connect the speaker output on the radio's accessory connector via testbox RLN4460B to the audio input on the IFR.
 Setup IFR to:
 No System,
 AF Test,
 AF IN/OUT,
 Gen 1,2,3 Off,
 Distortion On
 Run Tetra Com script for RX audio test
 Measure the 1kHz audio signal with a scope

Tetra Com Script for RX Audio Test

```

TEST_ENTER
DELAY 18
Check for "Radio HW is READY"
MODE IDLE
DSP_LOOP OFF
GEN_TONE 1000
DSP_VOL -5
VOL_M 27
SPKR INT
    
```

1kHz signal at FL0200 pin 2 ?

No

Before replacing FL0200 check for activity on pin 7,8,11,13

Yes

If no 1kHz signal at accessory connector pin 11, check stage U0206-1

1kHz signal at U0201 pin 5 ?

No

Before replacing U0204 check resistors R0221, R0228 and 3V DC at pin 8

1kHz signal at U0201 pin 4 ?

No

0V DC at U0201 pin 9 ?

No

Check transistor Q0203

Yes

If no 1kHz signal at handset audio output, check stage U0206-2

8.5V DC at U0205 pin 8 ?

No

Check collector of transistor Q0200 and connected resistors. Before replacing check mute to low.

Yes

If no 1kHz signal at speaker output, check R0244, R0245, C0227, 13.2V at pin 7 before replacing U0205.

9.3V DC at U0201 pin 16 ?

No

9.3V DC supply failure! Go to DC Supply Chart

Yes

Replace U0201

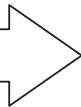

Transmitter Audio Troubleshooting

Failure:
 No audio, low audio level or distortion > 2% at speaker output during transmitter audio test.
 PATS parameters AUD_LBACK_GAIN or AUD_LBACK_DIST failed.

```

Tetra Com Script for TX Audio Test
TEST_ENTER
DELAY 18
Check for "Radio HW is READY"
MODE IDLE
GEN_TONE OFF
DSP_LOOP ON
DSP_VOL 0
VOL_M 24
MICGA_M 27
MIC PHF
SPKR INT
    
```

If receiver audio has not been checked, go to Receiver Audio Chart first.
 Connect the speaker output on the radio's accessory connector via testbox RLN4460B to the audio input on the IFR.
 Connect the microphone input on the radio's accessory connector via testbox RLN4460B to the audio output on the IFR.
 Setup IFR to:
 No System,
 AF Test,
 AF IN/OUT,
 Gen 1 On,
 AF 1 Frequency 1kHz
 AF 1 Level 80mV
 Distortion On
 Run Tetra Com script for TX audio test
 Measure the 1kHz audio signal with a scope

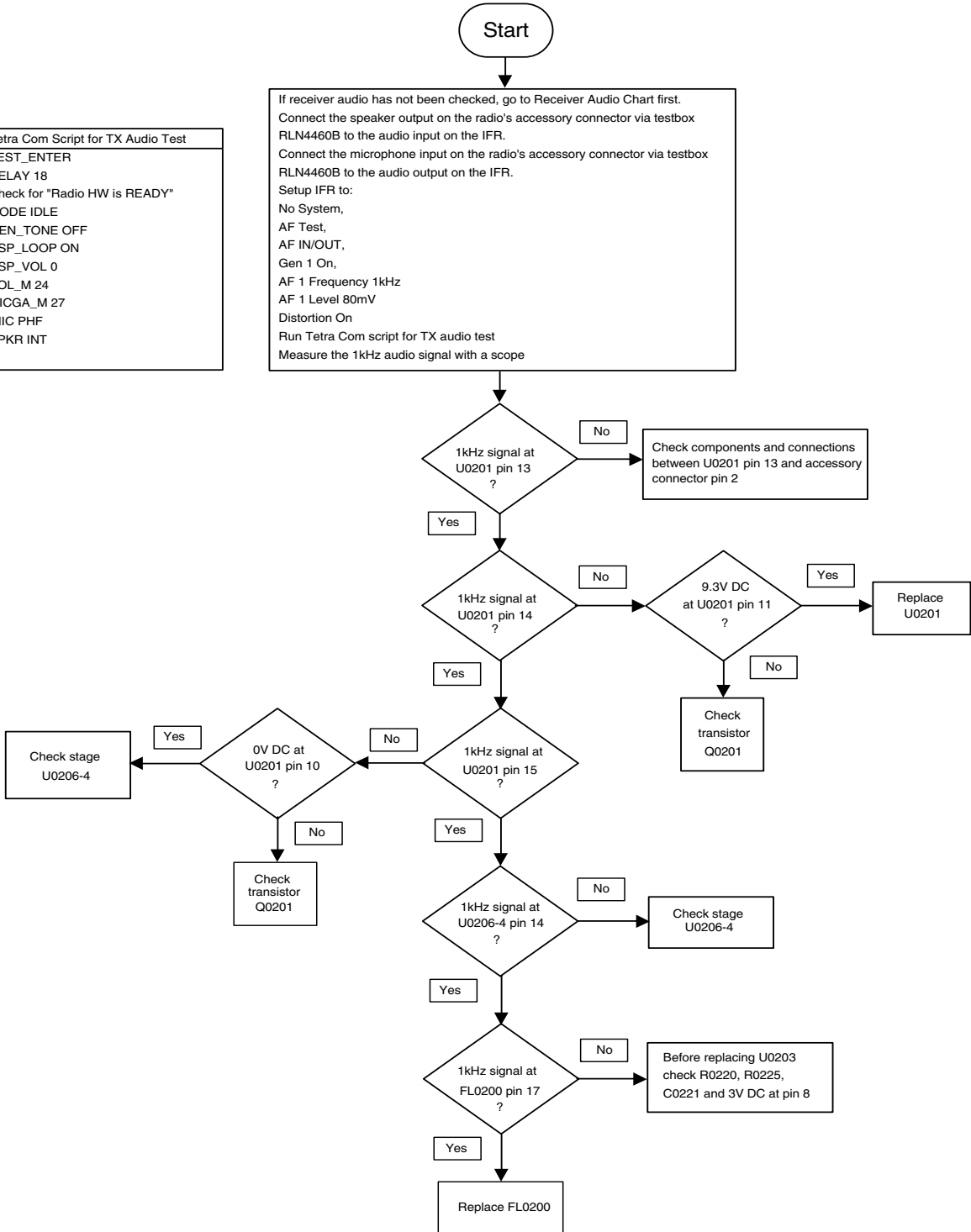

Warping Failure Troubleshooting

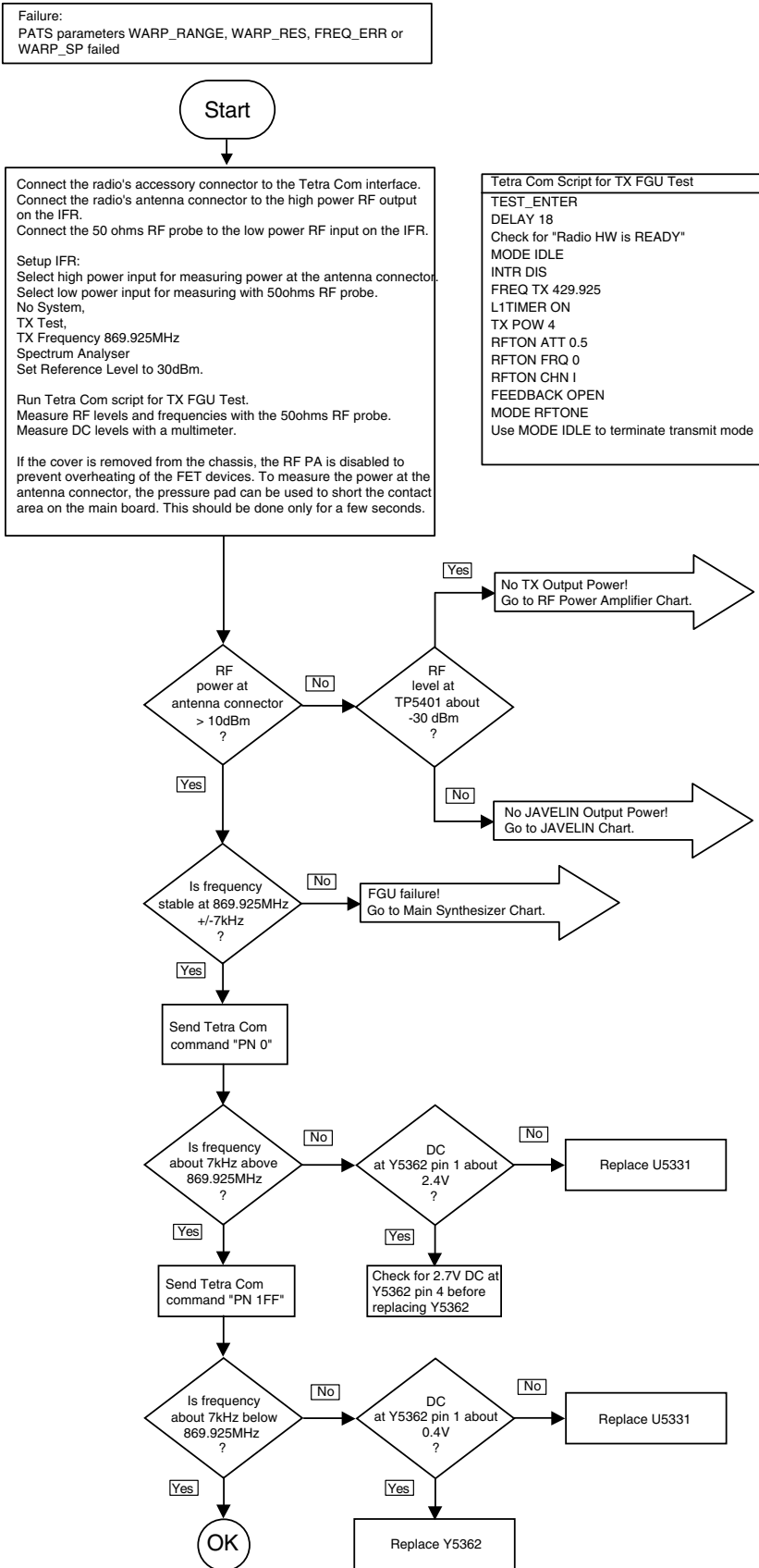

Low Tx Power Troubleshooting

Failure:
 No or low RF output power.
 Too high RF output power.
 PATS parameters ADJ_PWR1-5, ATT_SP1-5,
 DC_CUR1-5, TX_PWR_F1-5 failed.

Tetra Com Script for Tx Power Test:

```

TEST_ENTER
DELAY 18
Check for "Radio HW is Ready"
MODE IDLE
INTR EN
FREQ TX 869.925
L1 TIMER ON
TXPOW 6
MODE TXNDC
Use MODE IDLE to terminate transmit
mode
    
```

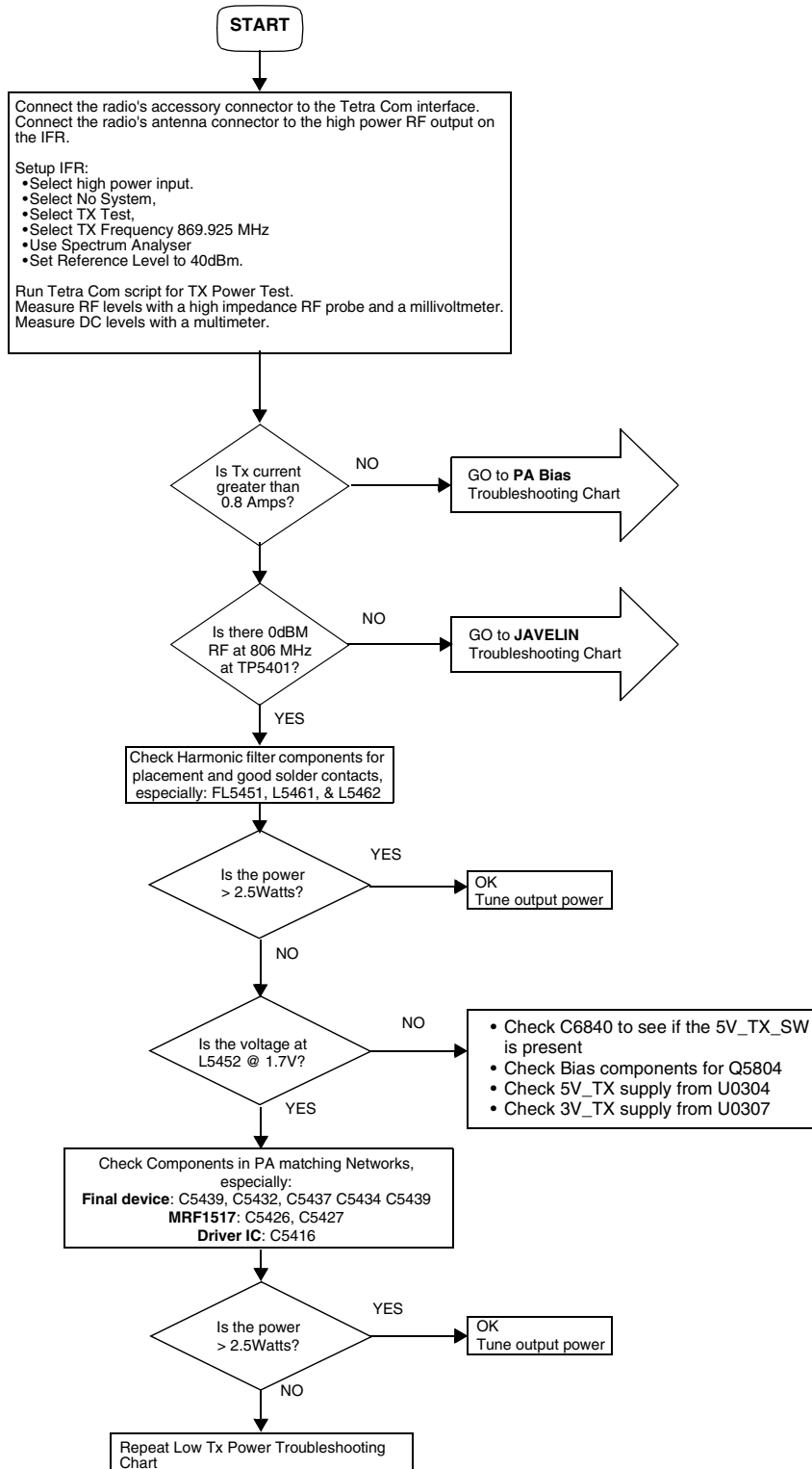

PA Bias Failure Troubleshooting

Failure:
PATS parameters PA_BIAS, BIAS1-3_CUR, BIAS1-3_SP failed.

```

Tetra Com Script for PA Bias Test:

TEST_ENTER
DELAY 18
Check for "Radio HW is READY"
MODE_IDLE
INTR_DIS
FREQ_TX 806.075
L1TIMER_ON
TXPOW 1
RFTON_ATT 0
RFTON_FRQ 10
RFTON_CHN IQ
PA_OFF
PA_BIAS_M 1 0
PA_BIAS_M 2 0
PA_BIAS_M 3 0
PA_BIAS_TBL_M 1
PA_BIAS_TBL_M 2
PA_BIAS_TBL_M 3
MODE_RFTONE
Use MODE_IDLE to terminate
RFTONE mode
    
```

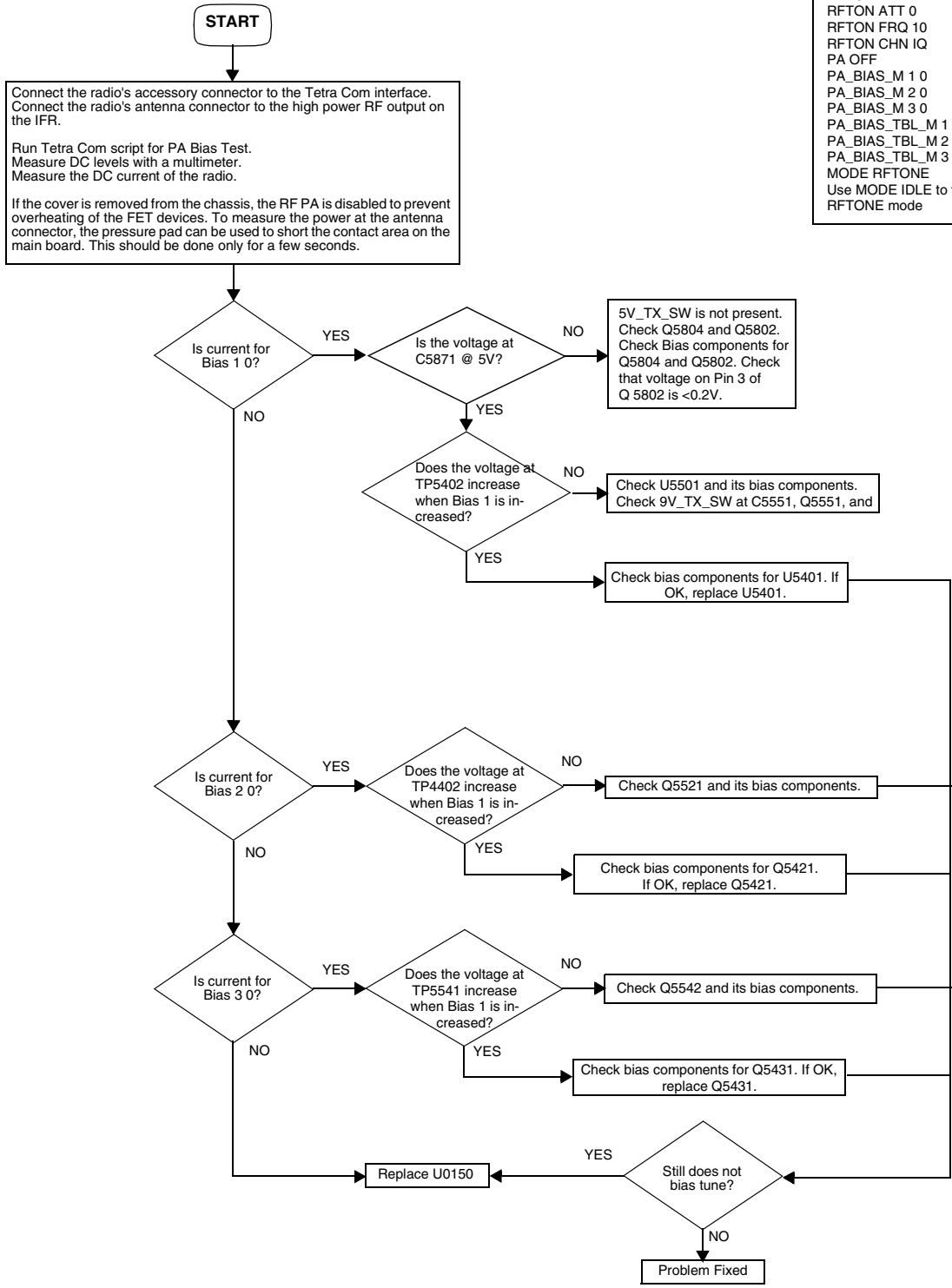

JAVELIN Troubleshooting

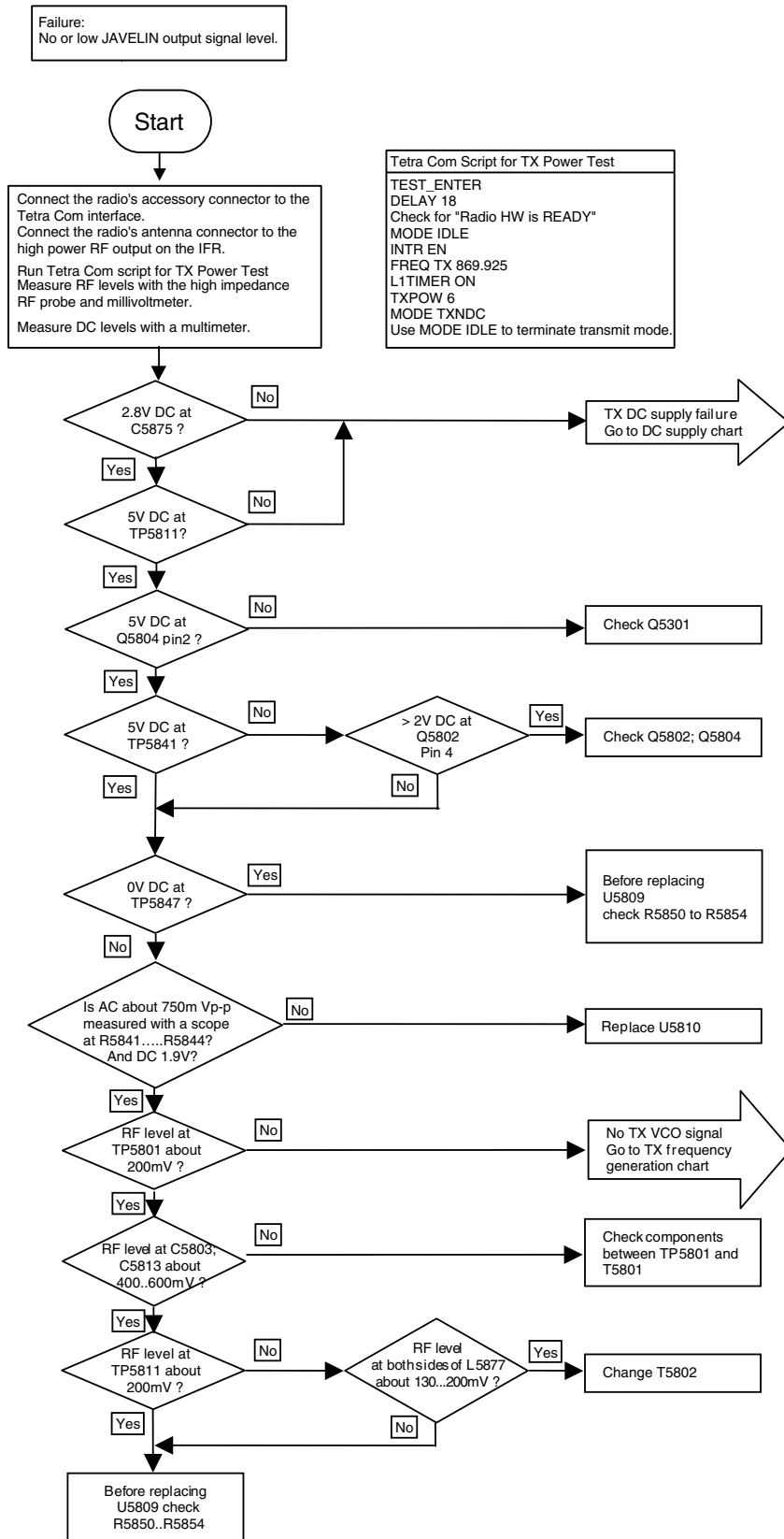

Receiver Troubleshooting (Sheet 1)

Failure:
 Bit Error Rate @ -114dBm >3.5%
 RSSI error > ±5dB

```

    Tetra Com Script for Rx Test:

    TEST_ENTER
    DELAY 18
    Check for "Radio HW is READY"
    MODE IDLE
    FREQ RX 860.525
    L1TIMER ON
    AVE 10
    MODE RSSI
    GO
    Use STOP to terminate RSSI
    reading
    
```

Inspect RF input path. Input a strong RF signal of about -40dBm at 860.525 MHz at the RF connector and check signal at Pin4 of the Mixer U5002.

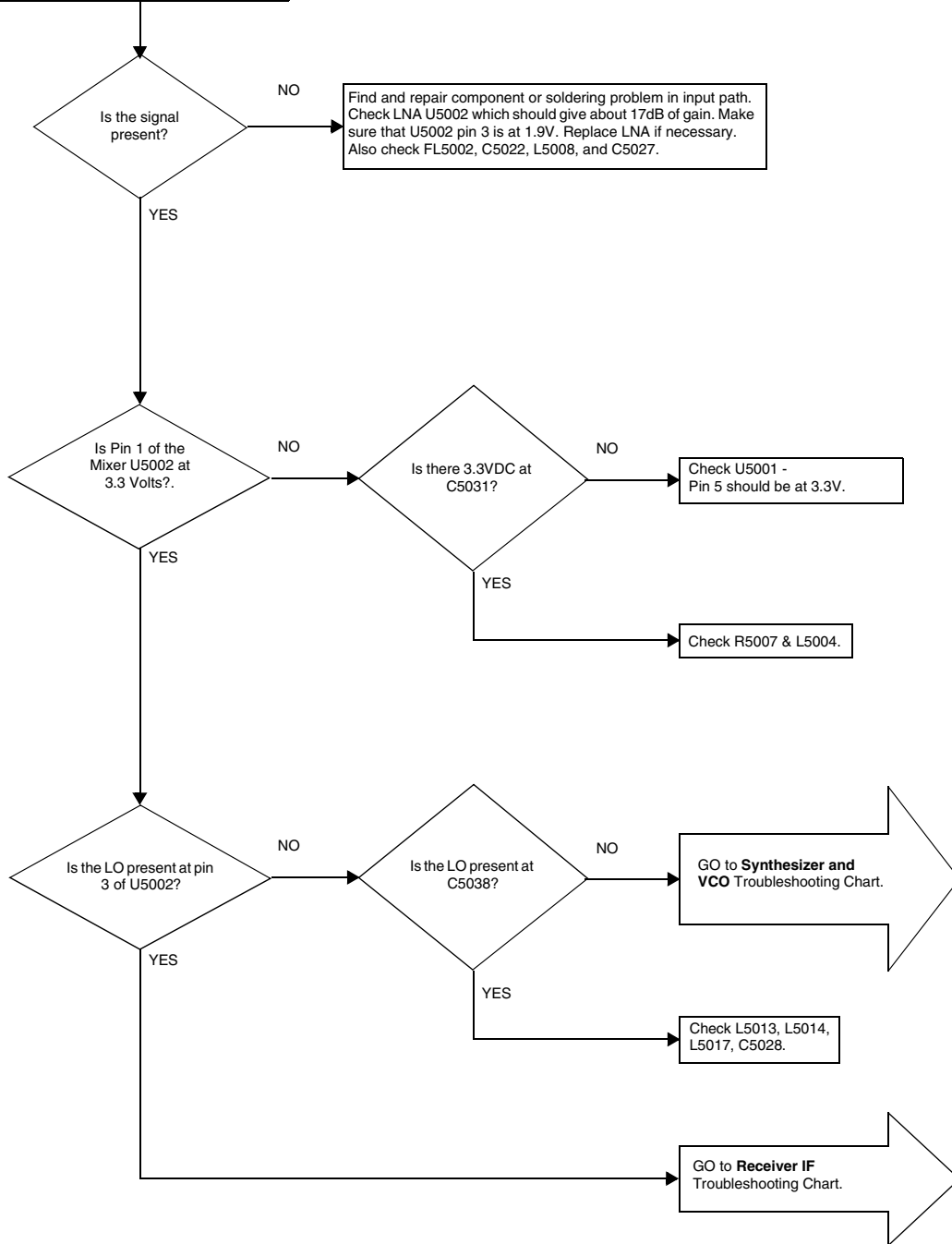

Receiver Troubleshooting (Sheet 2)

```

Tetra Com Script for Rx Test:

TEST_ENTER
DELAY 18
Check for "Radio HW is READY"
MODE IDLE
FREQ RX 860.525
L1TIMER ON
AVE 10
MODE RSSI
GO
Use STOP to terminate RSSI reading
    
```

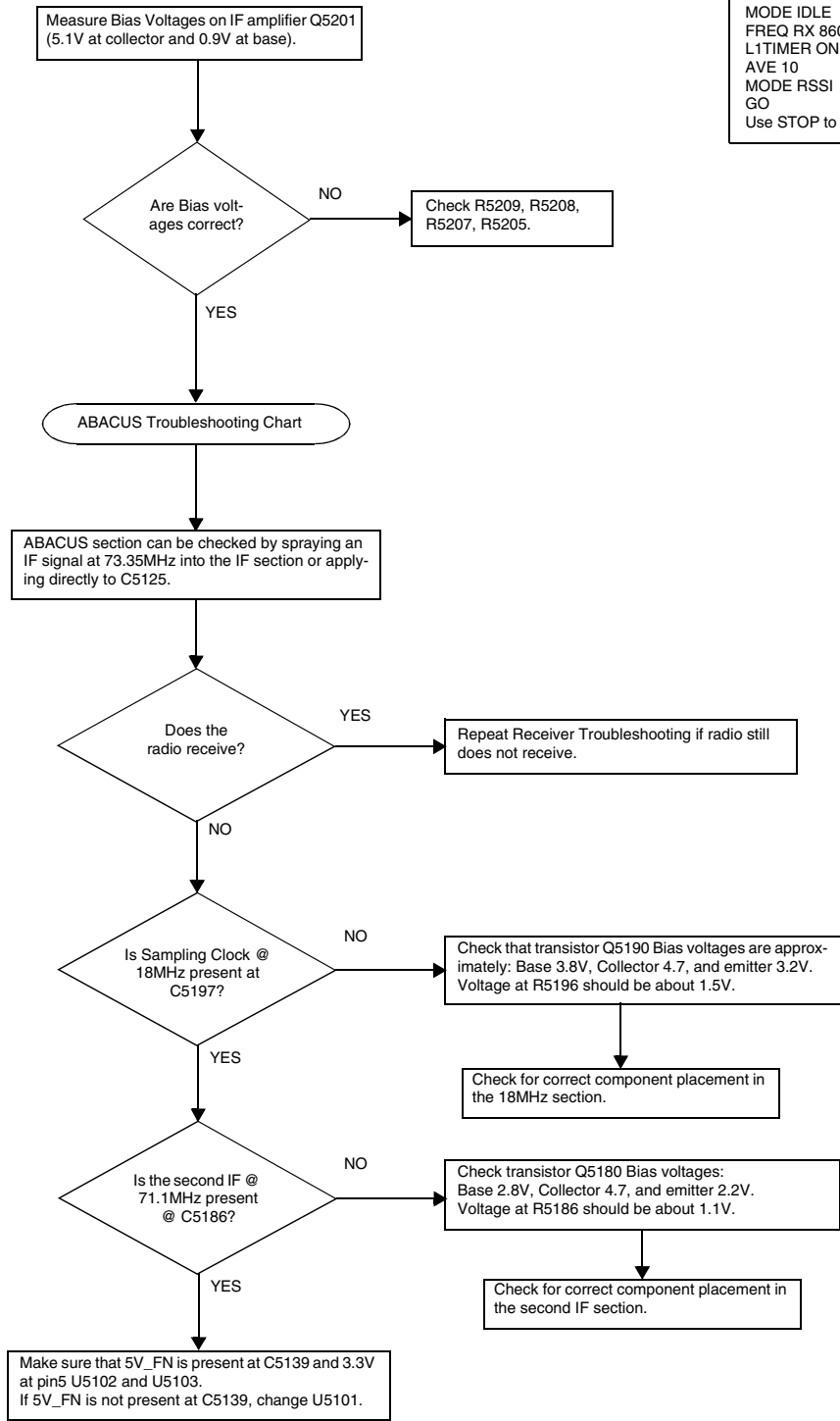

Tx Frequency Generation Troubleshooting

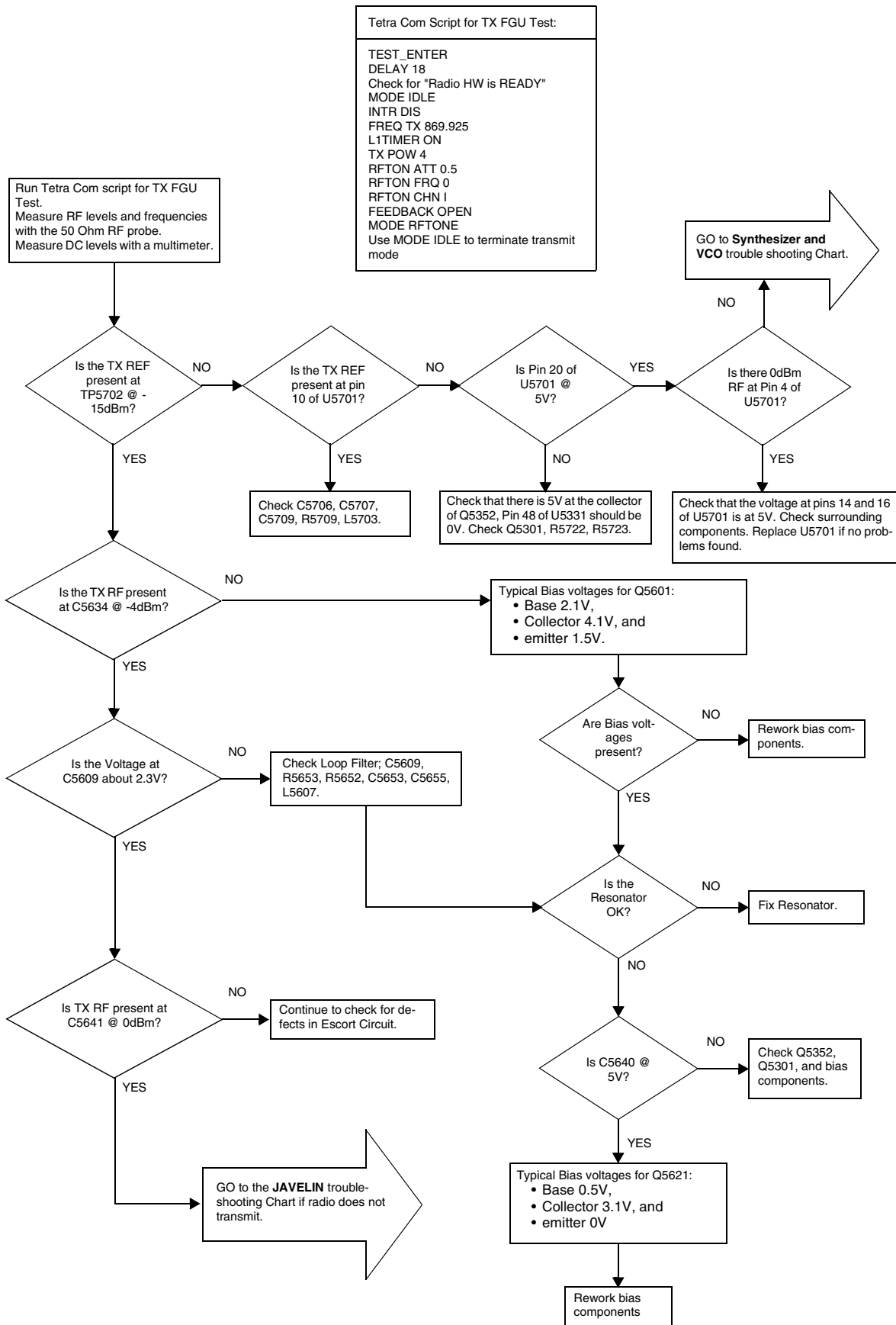

Synthesizer & VCO Troubleshooting

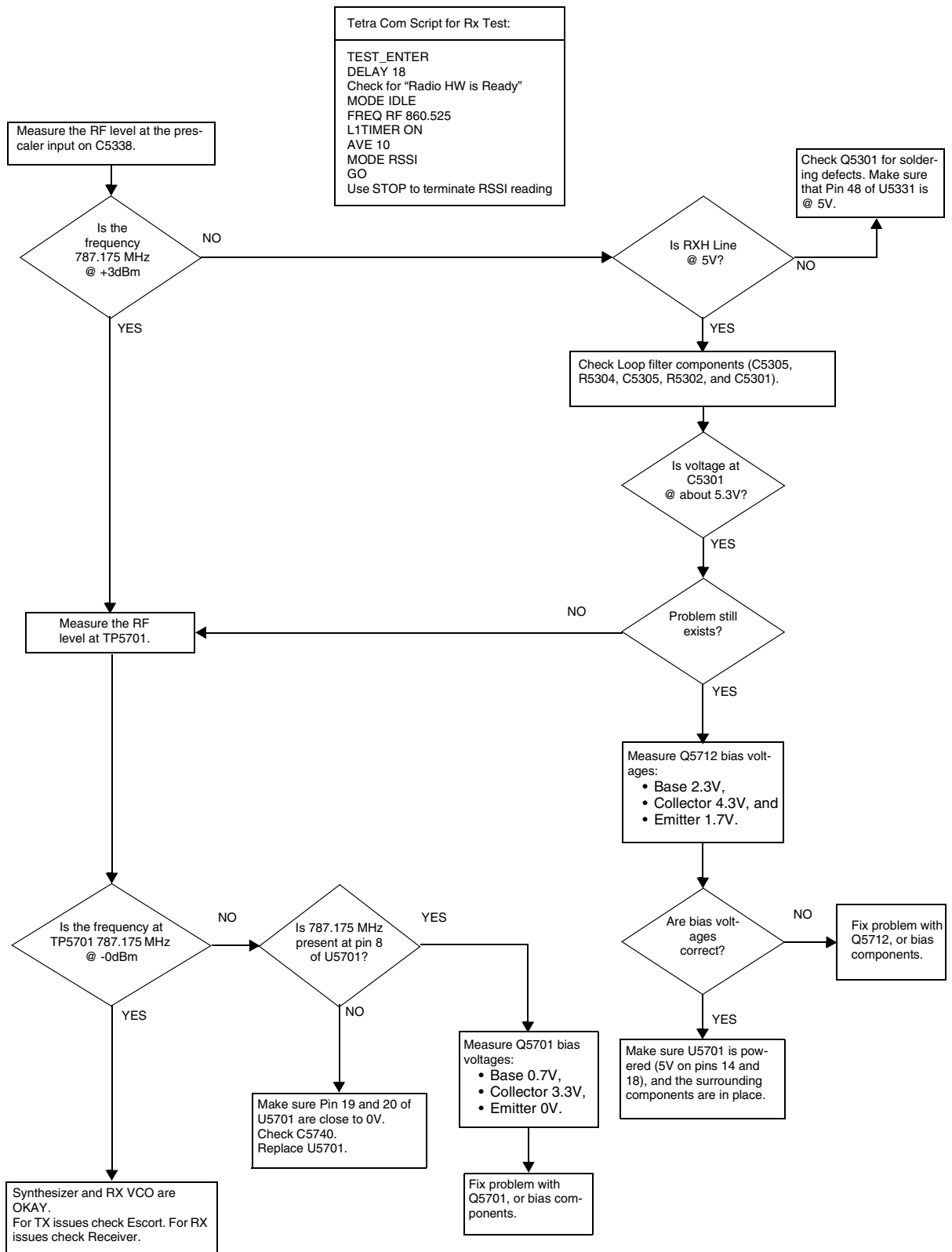

THIS PAGE INTENTIONALLY LEFT BLANK

APPENDIX A

CONNECTOR PIN FUNCTIONS



CAUTION: The connections shown are not compatible to some other models of Motorola terminals. Check the appropriate accessory or technical manual for further information.

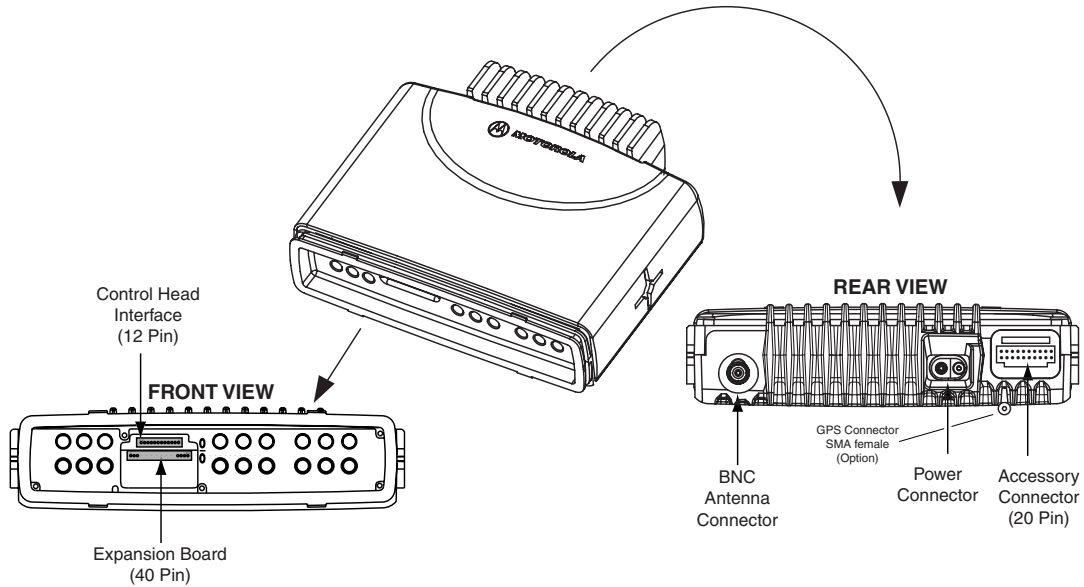

Figure 1 Schematic view of the Connectors / MTM800 ENH Transceiver

Transceiver Rear - Pin Function

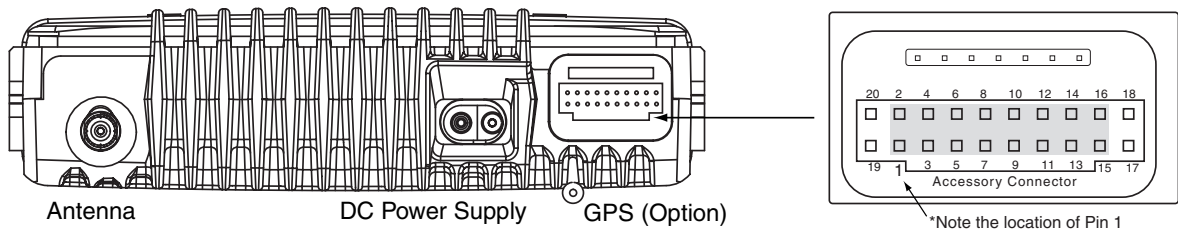

Figure 2 Rear view of the MTM800 ENH

Pin	Function	Description
1	EXTERNAL SPEAKER -	Speaker – and Speaker + (Pin 16) are used to connect an external speaker. The audio PA is a bridge amplifier with a minimum load resistance of 3.2 ohms.
2	EXTERNAL MIC AUDIO	External-, Emergency-, or Hot-Microphone; depends on CPS programming. This microphone signal is independent of the microphone signal on the microphone connector. The nominal input level is 80mV _{RMS} . The DC impedance is 660Ohms. The AC impedance is 560Ohms.

Table 18 Transceiver Pin Assignment of the Rear Accessory Connector

3	EXTERNAL PTT	This is a digital input to trigger external PTT; active low; non active high
4	EXTERNAL ALARM	This is a digital output for External Alarm / Fault Indication; active low; open collector with 4k7 Ohms pull up to B+;
5	TX_AUDIO	This input is intended for injecting signals into the transmit path. Input impedance > 10 k Ohms; input level = 775mV _{RMS}
6	KEYFAIL / FLASH	This line supports the encryption module.
7	ANALOG GROUND	Ground
8	DIGITAL_GROUND	Ground
9	EMERGENCY	To activate this functionality the pin has to be connected to ground. This will turn on the terminal, Low active.
10	IGNITION	Connecting this pin to the ignition line of the vehicle that will automatically turn on the terminal if the ignition of the vehicle is turned on, High active.
11	RX_AUDIO	This is the received RX signal. Output impedance approximate 600 Ohms unsymmetrical, output level = 775mV _{RMS}
12	AUDIO_PA_ENABLE	This is a digital input. High level or pin open enables the audio PA; Low level disables the audio PA.
13	SWB +	This voltage is available when the terminal is switched on. The max. current is 1.0A w/o GPS board and 0.8A with GPS board mounted.
14	HOOK	This is a high active digital input. Low = on hook; High = off hook
15	SCI_DTR	Reserved for service aid.
16	SPEAKER +	Positive output of terminal's audio PA (see Pin 1)
17 *	SCI_CTS	Terminal OUTPUT: Clear To Send (<i>reserved for service aids</i>)
18 *	SCI_RTS	Terminal INPUT: Request To Send (<i>reserved for service aids</i>)
19 *	SCI_RXD	Terminal OUTPUT: Receive Data (<i>reserved for service aids</i>)
20 *	SCI_TXD	Terminal INPUT: Transmit Data (<i>reserved for service aids</i>)

Table 18 Transceiver Pin Assignment of the Rear Accessory Connector

NOTE *	The 4-wire 3 Volts SCI interface on the accessory connector (pins 17 -20) can only be used for flashing of terminal firmware and programming software features. It can NOT be used for communication during normal terminal operation.
---------------	---

Transceiver Front - Pin Function

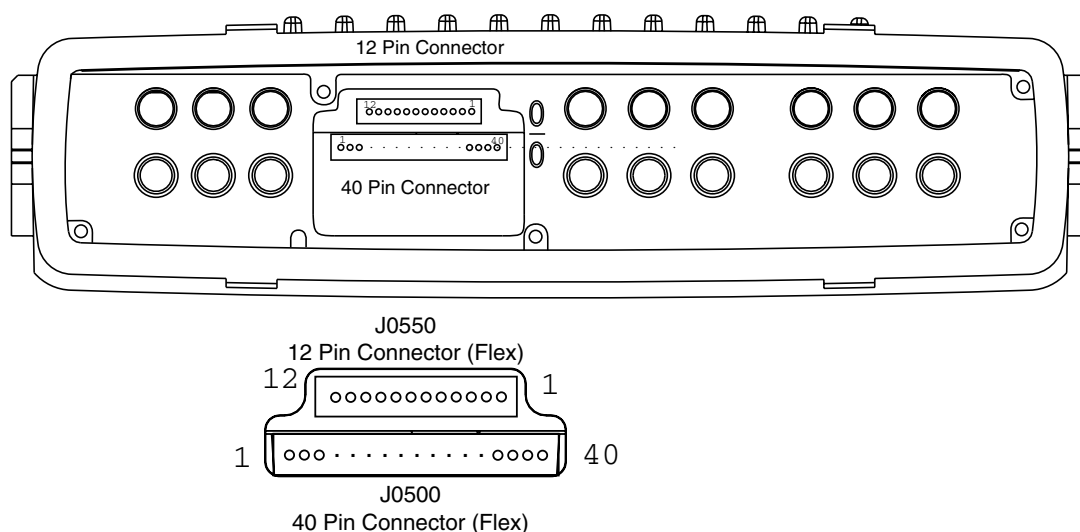

Figure 3 Transceiver Front View to the Enhanced Control Head Interface (12pins) and Expansion Head Connector (40pins)

Pin	Function	Description
1	SCI_TX	Serial Communication Interface TXD
2	SPEAKER +	Analogue Speaker output +
3	SPEAKER -	Analogue Speaker output -
4	GND	Ground
5	DIG_IN1 (Ext. PTT)	This is a digital input to trigger external PTT; active low; non active high
6	5VD	+ 5V regulated
7	HANDSET_AUDIO	Handset audio
8	BUS +	Either SBEP or Serial Communication Interface RXD
9	INT_MIC	Microphone input
10	FLT_A +	Filtered A+
11	ON_OFF_CONTRO_SV	Terminal On/Off Control shared with Control Head request
12	GND	Ground

Table 19 Transceiver Pin Assignment of the Enhanced Control Head Interface (12 pins)

Pin	Function	Description
1	GND	Ground
2	MUX_CTRL	TBA for future applications.
3	SPIB_CLK	Part of the QSPIB
4	MUX_CTRL_1	To detect RS232 or SB9600 Mode (3V SB9600 / 0V RS232) *
5	A+ (via 22Ohms)	Continuous battery voltage for sense via 22Ohms.
6	RESET_OUT	Reset; its a output to Reset a SB9600 device.*
7	BUSY_OUT	Busy Out for SB9600 Interface Circuit *
8	BUSY_IN	Busy In for SB9600 Interface Circuit *
9	3V3_DIG	3.3V Sense Output (max. 10mA)
10	EXP_REQ	Request Line from 4Wire/SB9600 UART *
11	SPIB_CS1_UART	Part of the QSPIB (ship select) for 4wire RS232 UART
12	SPIB_CS_BT	Part of the QSPIB (ship select) for future applications
13	SPIB_MISO	Part of the QSPIB
14	NC	Not Connected
15	SPIB_MOSI	Part of the QSPIB
16	NC	Not Connected
17	SAP_CLK	Serial Audio Protocol, Clock.
18	GND	Ground
19	INT_MIC	Microphone Input
20	MIC	Microphone Audio; for future applications
21	EXPANSION_PTT	Expansion PTT
22	BIUE_T_FSYNC	Serial Audio Protocol, Frame Sync.
23	SAP_SRD	Serial Audio Protocol, Receive Data
24	SAP_STD	Serial Audio Protocol, Transmit Data
25	DGAN_SAP_FSYNC	Serial Audio Protocol, Frame Sync.
26	SP_AUDIO	Audio PA Input; for future applications
27	TERMINAL ON/OFF (IGNITION)	High active.
28	EXT_MUTE	External mute of audio PA; for future applications
29	RS232_DCD	Data Carrier Detect
30	RS232_TX	TX-Data
31	RS232_DSR	Data Set Ready

Table 20 Transceiver Pin Assignment of the Expansion Board Connector (40 pins)

*) For Expansion Head Connection only.

32	RS232_RTS	Request To Send
33	RS232_DTR	Data Terminal Ready
34	RS232_CTS	Clear To Send
35	RS232_RX	RX-Data
36	RS232_RI	Ring Indicator
37	OPTION_DET	Option Detect; for future applications
38	9V3	Regulated 9V3
39	NC	Not Connected
40	HANDSET AUDIO	Handset Audio to earpiece

Table 20 Transceiver Pin Assignment of the Expansion Board Connector (40 pins)

*) For Expansion Head Connection only.

Enhanced Control Head - Pin Function

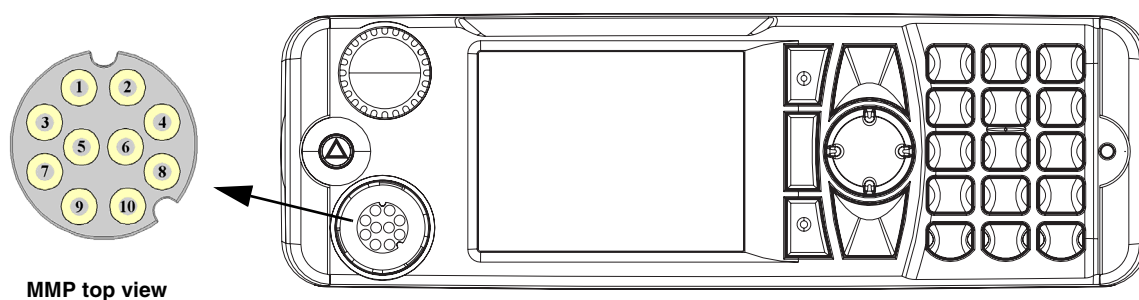

Figure 4 View of the Enhanced Control Head with GCAI MMP Connector

GCAI Pin #		Default Function	Alternative Functions	Functions when USB	Functions when RS232
1	1-WIRE	1-WIRE	1-WIRE	1-WIRE	1-WIRE
2	GPIO_3	PTT	GP Input or Output	GP Input or Output	RS-232-RTS *
3	SPEAKER	SPEAKER	SPEAKER	SPEAKER	SPEAKER
4	GPIO_2	GPIO_2 INPUT	GP Input or Output	DATA -	RS-232-RXD *
5	GND	GND	GND	GND	GND *
6	OPT 5V	HIGH Impedance	OPT 5V	VBUS	OPT 5V
7	MIC +	MIC +	MIC +	MIC +	MIC +
8	GPIO_1	GPIO_1 INPUT	GP Input or Output	DATA +	RS-232-TXD *
9	GPIO_4	HOOK	GP Input or Output	GP Input or Output	RS-232-CTS *
10	GPIO_0	GPIO_0 INPUT	GP Input or Output, PWR ON	GP Input or Output, PWR ON	GP Input or Output, PWR ON

Table 21 Pin assignment GCAI - FRONT – Microphone Mobile Port (MMP) / *): Optional

Remote Mount Head - Pin Function



Figure 5 View of the Remote Mount Connector

Pin	Function	Description
1	FLT_A+	Filtered A+
2	5V	+ 5V regulated / 100mA
3	ON_OFF_CONTROL	Terminal On/Off Control
4	GROUND	Ground
5	SPEAKER -	Analogue Speaker output +;Speaker impedance has to be > 20 Ohm
6	INT_MIC	Microphone analogue input of 80mVRMS, 600 Ohm impedance, 9V=
7	BUS +	SBEP Bus
8	SPEAKER +	Analogue Speaker output +;Speaker impedance has to be > 20 Ohm
9	HANDSET_AUDIO	Handset audio to earpiece impedance has to be > 200 Ohm
10	GROUND	Ground

Table 22 Pin Assignment of the 10 Pin TELCO-Connector of the Remote Mount Head

Expansion Head - Pin Function

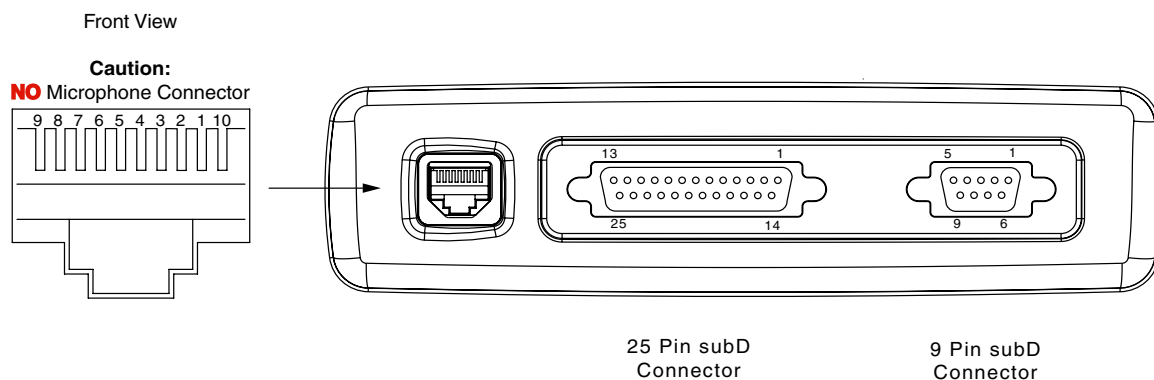

Figure 6 View of the Expansion Head Connectors

Pin	Function	Description
1	FLT_A+	Filtered A+
2	5V	+ 5V regulated / 100mA
3	ON_OFF_CONTROL	Terminal On/Off Control
4	GROUND	Ground
5	SPEAKER -	Analogue Speaker output +;Speaker impedance has to be > 20Ohms
6	INT_MIC	Microphone analogue input of 80mVRMS,600 Ohm impedance,9V=
7	BUS +	SBEP Bus
8	SPEAKER +	Analogue Speaker output +;Speaker impedance has to be > 20 Ohms
9	HANDSET_AUDIO	Handset audio to earpiece impedance has to be > 200 Ohms
10	EXPANSION_PTT	Expansion PTT, works together with INT_MIC

Table 23 Pin Assignment of the 10 Pin TELCO Connector of the Expansion Head

Pin	Function	Description	PC direction
1	DCD	Data Carrier Detect	Input
2	RXD	Received Data	Serial IN
3	TXD	Transmitted Data	Serial OUT
4	DTR	Data Terminal Ready	Output
5	GND	Ground	Output

Table 24 Pin Assignment of 9 Pin subD Connector of the Expansion Head

6	DSR	Data Set Ready	Input
7	RTS	Request to Send	Output
8	CTS	Clear to Send	Input
9	RI	Ring Indicator	Input

Table 24 Pin Assignment of 9 Pin subD Connector of the Expansion Head

Pin	Function	Description
1	GND	Ground
2	RS232_SCI_TX	Transceiver data (RS232 line with RS232 level)
3	RS232_SCI_RX	Receive data (RS232 line with RS232 level)
4	RS232_RTS	Request to Send (RS232 line with RS232 level)
5	RS232_CTS	Clear to Send (RS232 line with RS232 level)
6	FLT_A+	Filtered unswitched UB+ / 200mA
7	Signal_GND	Ground for RS232
8	SB9600_BUSY	SB9600 busy
9	NC	Not Connected
10	NC	Not Connected
11	NC	Not Connected
12	SW_B+	Switched UB+ / 100mA
13	SB9600_BUS-	SB9600 BUS-
14	ON_OFF_CONTROL / FLASH_MODE	-Switch into flash mode (connect pin14 with 6) -On/Off control for Std. Control Head
15	SB9600_BUS+	SB9600 BUS+
16	INT_MIC	Microphone analogue input of 80mVRMS, 600ohm impedance, 9V=
17	SB9600_RESET	Reset; its a output to reset a SB9600 device
18	NC	Not Connected
19	GROUND	Ground
20	IGNITION	Connecting this pin to the ignition line of the vehicle that will automatically turn on the terminal if ignition of the vehicle is turned on. High active;
21	ON_OFF_GND	On/Off control for Control Head "J"(MTM300 C/H)
22	EXPANSION_PTT	Expansion PTT, works together with INT_MIC
23	SB9600_SW	switched into SB9600 mode if connected to 12V
24	HANDSET_AUDIO	Handset audio to earpiece impedance has to be > 200 Ohm
25	NC	Not Connected

Table 25 Pin Assignment of the 25 Pin subD Connector of the Expansion Head

Motorcycle & Remote Mount Connection - Pin Functions

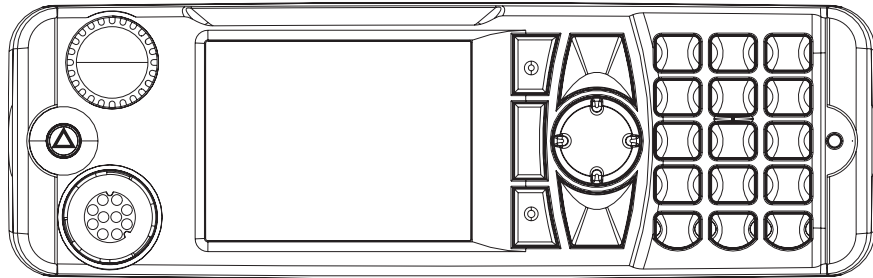

Figure 7 Front View of the Motorcycle Control Head

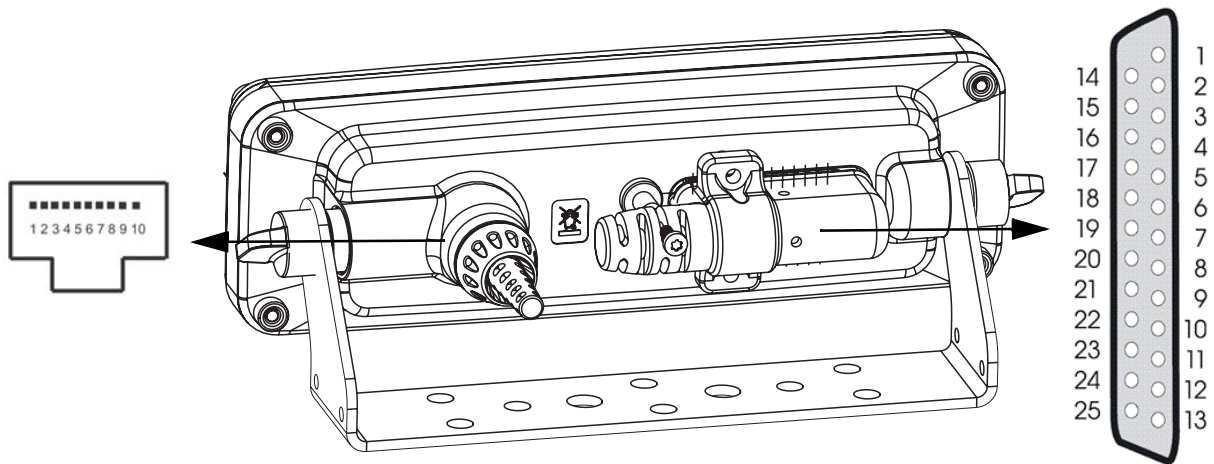

Figure 8 Rear View of the Motorcycle Control Head

Pin	Function	Description	Default
1	GPIO_9	GPIO, open collector, 4.7k to FLT_A+ PU Output: 200mA @ low, 0,5mA @ high Input: high > 2V, low < 0.5V	Output: Active for duration of call (car radio mute)
2	GPIO_6	GPIO, open collector, 4k7 to 5V PU Output: 1mA @ low, 0,5mA @ high Input: high > 2V, low < 0.5V	PTT Input, TX audio from MIC_REAR_2
3	GPIO_8	GPIO, open collector, 4k7 to 5V PU Output: 1mA @ low, 0,5mA @ high Input: high > 2V, low < 0.5V	Disabled
4	GPIO_3	GCAI PIN 2: 15k to 3V3 PU, 5V tol. Output: see GCAI spec. 1.20 Input: high > 2V, low < 0.5V	PTT Input, TX audio from MIC_REAR_1
5	VBUS_1B	GCAI PIN 6: 5V Supply	Disabled
6	REAR_D-	GCAI PIN 4: USB D-, GPIO_2 shared with front MMP	Disabled
7	REAR_D+	GCAI PIN 8: USB D+, GPIO_1 shared with front MMP	Disabled
8	GPIO_0	GCAI Pin 10 GPIO, open coll., 15k to 3V3 PU, 5V tol. Output: see GCAI spec. 1.20 Input: high > 2V, low < 0.5V	Input, GCAI etection/Select Line

Table 26 Pin assignment of the 25pin back connector – for RMC and MCC

Pin	Function	Description	Default
9	VBUS_2	Second USB, 5V Supply	Disabled
10	TX	4 wire RS232 TX, EIA/TIA-232 level	
11	RX	4 wire RS232 RX, EIA/TIA-232 level	
12	MIC_REAR_2	2nd REAR MIC Input 80mVrms Bias 9V= / 600Ohm	Disabled
13	GND	GND	
14	GPIO_5	GPIO, open collector, 4k7 to 5V PU Output: 1mA @ low, 0,5mA @ high Input: high > 2V, low < 0.5V	Disabled
15	GPI_7	4 Level Analogue Input, 33k to 5,0V PU (refer to graphic below)	Enabled
16	1_WIRE	GCAI PIN 1, 1-Wire® bi-directional serial bus	Disabled
17	HANDSET	GCAI PIN 3, Handset audio output, VOL onrolled, AC coupled, min. RL 150Ohm	Parallel to front GCAI
18	GND	GCAI PIN 5 GND	
19	MIC_REAR_1	GCAI PIN 7 MIC Input 80mVrms Bias 9V= / 600Ohm	Disabled
20	GPIO_4	GCAI PIN 9 GPIO open collector, 15k to 3V3 PU, 5V tol. Output: see GCAI spec. 1.20 Input: high > 2V, low < 0.5V	Hook Input
21	USB_D+	Second USB, D+	
22	USB_D-	Second USB, D-	
23	RTS	4 wire RS232 RTS, EIA/TIA-232 level	
24	CTS	4 wire RS232 CTS, EIA/TIA-232 level	
25	PWR_ON	NGCH Power On input, high active, > 2V	

Table 26 Pin assignment of the 25pin back connector – for RMC and MCC

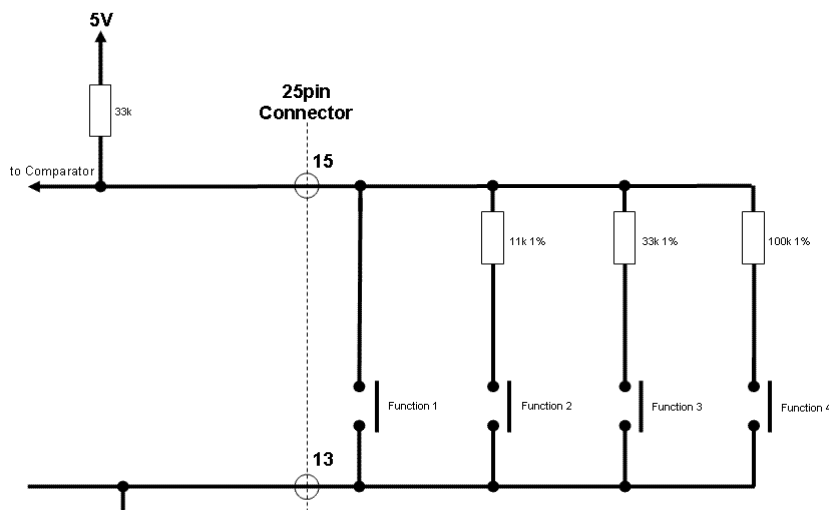

Figure 9 4 Level Analogue Input provided by GPI_7

Function	Voltage Level (V)	Tolerance (V)	Default Function
1	0,00	0.000 - 0,625	Volume Up
2	1,25	0,625 - 1,875	Volume Down
3	2,50	1,875 - 3,125	Talk group Up
4	3,75	3,125 - 4,375	Talk group Down
Idle	5,00	4,375 - 5,000	

Table 27 Function of the voltage level at GPI_/_

TELCO top view	Pin #	Function	Description
	1	Audio +	Balanced Audio + (bidirectional)
	2	Spkr +	Speaker +
	3	BUS+	Serial Bus (115 kBd), Data from NGCH
	4	Audio -	Balanced Audio - (bidirectional)
	5	Spkr -	Speaker -
	6	GND	GND
	7	ON_OFF_CONTROL	Radio "Turn On" Signal
	8	SCI_TX	Serial Bus (115 kBd), Data to NGCH
	9	FLT_A+	Supply voltage
	10	GND	GND

Table 28 Pin assignment of the 10pin TELCO back connector for RMC and MCC

THIS PAGE INTENTIONALLY LEFT BLANK

APPENDIX B

REPLACEMENT PARTS & KITS

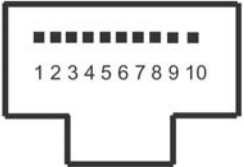
Servicing MTM800 ENH Mobile Units

Service for the mobile units is based on the substitution method; a faulty part is replaced by a working one, providing quicker service to the customer. For example, if the controller board is faulty, it is replaced. If the mobile requires more complete testing or servicing than that is available at field level, it is sent to the European Radio Service Centre; where it is serviced, and returned to the Regional Service Centre.

Level 1 and Level 2 Maintenance

This manual covers Level 1 and Level 2 Maintenance: at Level 1 maintenance you replace the transceiver and/or accessories and send the faulty transceiver and/or accessories to higher level of maintenance; at level 2 maintenance a transceiver board is replaced.

The MTM800 ENH mobiles are programmed at the factory. They cannot be tuned at the field service level.

Level 3 Maintenance

All Radio Support Depots are level 3 service partners. The depots are capable of performing repairs down to component level where retuning is required. Contact your local CGISS office for information.

Replacement Parts

Damaged parts should be replaced with identical replacement parts. For complete information on ordering required parts and kits, contact your local customer service representative (see following pages).

SERVICE INFORMATION

Europe, Middle East and Africa Region

European Radio Support Centre (ERSC)

Motorola European Radio Support Centre is available at:

Motorola European Radio Support Centre ERSC
Tel.: +49 (0)30 6686 1555
Fax: +49 (0)30 6686 1579
Am Borsigturm 130
13507 Berlin
Germany

EMEA Systems Support Centre (ESSC)

The Systems Support Centre is available at:

Telephone: +44 (0) 1256 484448

E-mail: ESSC@motorola.com

Piece Parts

Some replacement parts, spare parts, and/or product information can be ordered directly. If a complete Motorola part number is assigned to the part, it is available from Motorola Radio Aftermarket and Accessory Division (AAD). If no part number is assigned, the part is not normally available from Motorola. If a parts list is not included, this generally means that no user-serviceable parts are available for that kit or assembly.

Note on this digital Tetra Terminal: **The CPS has no capability to tune the terminal. Tuning the terminal can only be performed at the factory or at the appropriate Motorola Repair Centre. Components replacement can affect the terminal tuning and must only be performed by the appropriate Motorola Repair Centre.**

Parts identification and ordering

Request for help in identification of non-referenced spare parts should be directed to the Customer Care Organization of Motorola's local area representation. Orders for replacement parts, kits and assemblies should be placed directly on Motorola's local distribution organization or via the Extranet site Motorola Online at: <https://emeaonline.motorola.com>.

EMEA Test Equipment Support

Information related to support and service of Motorola Test Equipment is available by calling the Motorola Test Equipment Service in Germany at +49 (0) 6128 702179, Telefax +49 (0) 6128 951046, through the Customer Care Organization of Motorola's local area representation, or via the Internet at: <http://www.gd-decisionssystem.com/cte/>.

Asia, Pacific Region

Piece Parts

Some replacement parts, spare parts, and/or product information can be ordered directly. If a complete Motorola part number is assigned to the part, it is available from Motorola Radio Aftermarket and Accessory Division (AAD). If no part number is assigned, the part is not normally available from Motorola. If a parts list is not included, this generally means that no user-serviceable parts are available for that kit or assembly.

Note on this digital TETRA Terminal: **The CPS has no capability to tune the terminal. Tuning the terminal can only be performed at the factory or at the appropriate Motorola Repair Center. Component replacement can affect the terminal tuning and must only be performed by the appropriate Motorola Repair Center.**

All orders for parts/information should include the complete Motorola identification number. All part orders should be directed to your local AAD office. Please refer to your latest price pages.

Technical Support

Technical support is available to assist the dealer/distributor in resolving any malfunction which may be encountered. Initial contact should be by telephone wherever possible.

When contacting Motorola Technical Support, be prepared to provide the product model number and the unit's serial number.

Further Assistance From Motorola

You can also contact the Customer Help Desk through the following web address:
<http://www.motorola.com/governmentandenterprise/contactus>.

Parts identification and ordering

Request for help in identification of non-referenced spare parts should be directed to the Customer Care Organization of Motorola's local area representation. Orders for replacement parts, kits and assemblies should be placed directly on Motorola's local distribution organization or via Motorola Online (Extranet).

Latin America Region

Latin America Radio Support Centres

The Customer Support is available through the following service centres:

Warranty and Repairs:

MOTOROLA DE COLOMBIA SERVICE CENTRE

Carrera 7 No. 71-52
Torre B piso 13
Oficina 1301
Bogota- Colombia
(571) 376-6990

MOTOROLA DE MEXICO SERVICE CENTRE

Bosques de Alisos #125
Col. Bosques de las Lomas
CP 05120 Mexico DF
5252576700

Piece Parts:

To order parts in Latin America and the Caribbean contact your local Motorola CGISS representative.

MOTOROLA, INC.

Latin American Countries Region
789 International Parkway
Sunrise, FL 33325
USA 954-723-8959

MOTOROLA DE ARGENTINA

Ave. del Libertador 1855
B1638BGE, Vicente Lopez
Buenos Aires, Argentina
5411-4317-5300

MOTOROLA DE LOS ANDES C.A.

Ave. Francisco de Miranda
Centro Lido, Torre A
Piso 15, El Rosal
Caracas, 1060 Venezuela
58212-901-4600

MOTOROLA DO BRASIL LTDA.

Rua Paes Leme, 524, 13 Andar
05424-010 São Paulo, Brasil
5511-3030-5000

MOTOROLA CHILE

Ave. Nueva Tajamar 481
Edif. World Trade Center
Of. 1702, Torre Norte
Las Condes

Santiago, Chile
562-338-9000

MOTOROLA DE COLOMBIA, LTDA.

Carrera 7 #71-52
Torre A, Oficina 1301
Bogotá, Colombia
571-376-6990

MOTOROLA DE COSTA RICA

Oficentro Plaza Mayor
Piso 3, Rohrmoser
San José, Costa Rica
506-296-5385

MOTOROLA DEL ECUADOR

Núñez de Balboa #OE1-245
y Pedro Alfaro, Villa Flora
Quito, Ecuador
593-2264-1627

MOTOROLA DE MEXICO, S.A.

Calle Bosques de Alisos #125
Col. Bosques de Las Lomas
05120 México D.F.
México
52-555-257-6700

MOTOROLA DEL PERU, S.A.

Ave. República de Panama 3535
Piso 11, San Isidro
Lima 27, Peru
511-211-0700

Technical Support:

<https://businessonline.motorola.com>, go to Contact Us to request technical support

Some replacement parts, spare parts, and/or product information can be ordered directly. If a complete Motorola part number is assigned to the part, it is available from Motorola. If no part number is assigned, the part is not normally available from Motorola. If the part number is appended with an asterisk, the part is serviceable by Motorola Depot only. If a parts list is not included, this generally means that no user-serviceable parts are available for that kit or assembly.

SERVICE KITS

Type No.	Sales Model No.	Short Description	Model
MT912M	M80UCS6TZ5AN	MTM800 ENH 806-870 Dash	M1
MT912M	M80UCS6TZ4AN	MTM800 ENH 806-870 Desk	M2
MT912M	M80UCS6TZ6AN	MTM800 ENH 806-870 Remote	M3
MT912M	M80UCS6TZ2AN	MTM800 ENH 806-870 M'cycle	M4

Table 16 Service Kits-To-Model Chart

MTM800 Service Kits					
Description	Part Number	M1	M2	M3	M4
Service Boards		X	X	X	X
PMUF1368AS	MTM800 ENH 806-870 CLEAR	X	X	X	X
PMUF1369AS	MTM800 ENH 806-870 TEA1	X	X	X	X
PMUF1370AS	MTM800 ENH 806-870 TEA3	X	X	X	X
PMUF1371AS	MTM800 ENH 806-870 GPS CLEAR	X	X	X	X
PMUF1372AS	MTM800 ENH 806-870 GPS TEA1	X	X	X	X
PMUF1373AS	MTM800 ENH 806-870 GPS TEA3	X	X	X	X
PMUF1374AS	MTM800 ENH 806-870 UCM AES 128	X	X	X	X
PMUF1375AS	MTM800 ENH 806-870 UCM TEA1 AES 128	X	X	X	X
PMUF1376AS	MTM800 ENH 806-870 UCM TEA3 AES 128	X	X	X	X
PMUF1377AS	MTM800 ENH 806-870 UCM/GPS AES128	X	X	X	X
PMUF1378AS	MTM800 ENH 806 UCM/GPS TEA1 AES 128	X	X	X	X
PMUF1379AS	MTM800 ENH 806 UCM/GPS TEA3 AES 128	X	X	X	X
Enhanced Control Head/Kits					
Dash/Desk Mount -English Keypad	GMWN4298_	X	X		
Chinese Keypad	GMWN4299_	X	X		
Korean Keypad	GMWN4300_	X	X		
Arabic Keypad	GMWN4301_	X	X		
BoPoMoFo Keypad	GMWN4302_	X	X		
Cyrillic Keypad	GMWN4303_	X	X		
Remote Mount -English Keypad	GMWN4304_			X	
Chinese Keypad	GMWN4305_			X	
Korean Keypad	GMWN4306_			X	
Arabic Keypad	GMWN4307_			X	
BoPoMoFo Keypad	GMWN4308_			X	

Table 16 Service Kits-To-Model Chart

MTM800 Service Kits					
Cyrillic Keypad	GMWN4309_			X	
Motorcycle -English Keypad	GMWN4600_				X
Chinese Keypad	GMWN4601_				X
Korean Keypad	GMWN4602_				X
Arabic Keypad	GMWN4603_				X
BoPoMoFo Keypad	GMWN4604_				X
Cyrillic Keypad	GMWN4605_				X
Data Expansion Head	GMCE4053_			X	
Remote Mount Back Housing	GMCN4060_			X	
Remote Mount Transceiver Cover	GMCN4080_			X	
Cables/Kits					
Remote Mount Cable - 3m	RKN4077_			X	X
Remote Mount Cable - 5m	RKN4078_			X	X
Remote Mount Cable - 7m	RKN4079_			X	X
Remote Mount Cable - 10m	PMKN4020_			X	X
GCAI-USB Ext.Cable Kit	PMKN4029_			X	X

*) TETRA Encryption Algorithm 1 or 2

THIS PAGE INTENTIONALLY LEFT BLANK

APPENDIX C

RETROFITTING the GPS and UCM Board

Retrofitting the UCM and GPS module should only be done by specially authorized and educated Service Personnel. All operating and safety instructions are to be followed carefully.

Note: Refer to chapter 7 MAINTENANCE for dis-assembling and re-assembling the terminal properly.

Retrofitting the GPS board

1. Remove the metal blind cover from the bottom (5 screws, T10 TORX™).
2. Pull out the protection bushing.
3. Install the GPS board by starting with the connection of the flex to the mainboard.
4. Take care to fit the gasket of the coax cable in the right position for proper IP54 protection.
5. Fix the GPS board with one T10 TORX™ screw (1.13 Nm +/- 10% or 10 lbin +/- 10%).
6. Fix the GPS cover plate with five T10 TORX™ screws (1.13 Nm +/- 10% or 10 lbin +/- 10%).

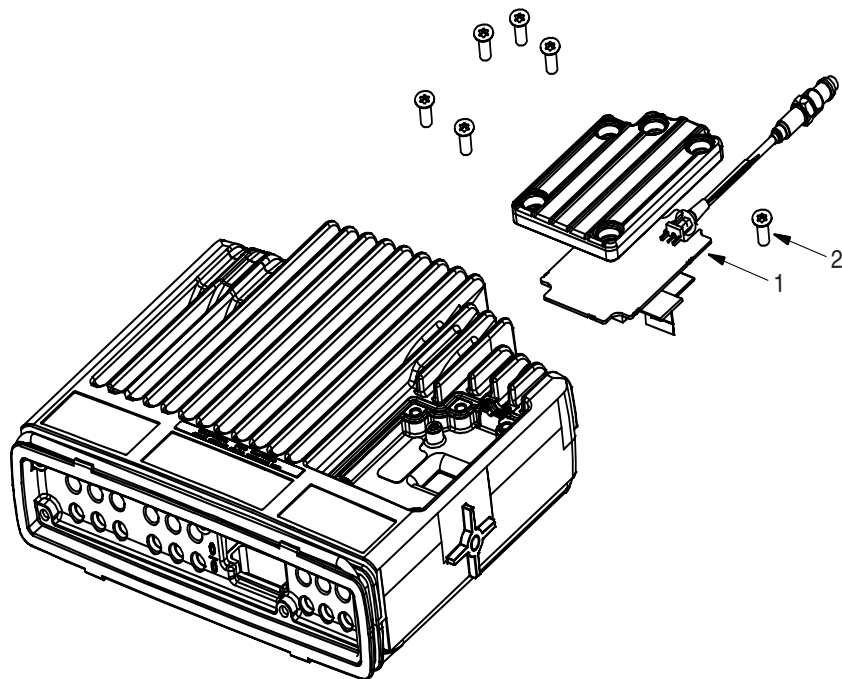

Figure 4 Position of GPS module at the terminal (view from bottom side)

Table 18 GPS Upgrade Kit Parts List

Item No.	Description	Part Number
	GPS Upgrade Kit	GMRG4219_
1	GPS Board (with flex and coax cable)	0166502N65
2	Screw (M3x8)	0310907A19
3	Label (not shown)	5466571B01

GPS Software activation

After installing the GPS hardware, a software upgrade for the MTM800 ENH will be necessary. Please refer to the CPS documentation in the Product Information Manual (P/N: 6866537D87) for more details or contact your local Customer Support Centre / see Appendix B - Service Information)

Retrofitting the UCM board

1. If attached, remove the control head from the terminal, refer to chapter 7 (page 7-5, following).
2. Remove the top plastic cover from the terminal.
3. Remove the six screws from the diecast cover using a T20 TORX™ driver and lift the cover from the chassis.
4. Fix the flex to the UCM board and place it at the cover plate.
5. Fix the plastic cover with 3 screws starting with the pull-through of the flex.
6. Place the cover plate (UCM at left side) in front of the transceiver front side and carefully attach the flex to the mainboard at the 40-pin internal option board connector (J0450).
7. Re-assemble the terminal.

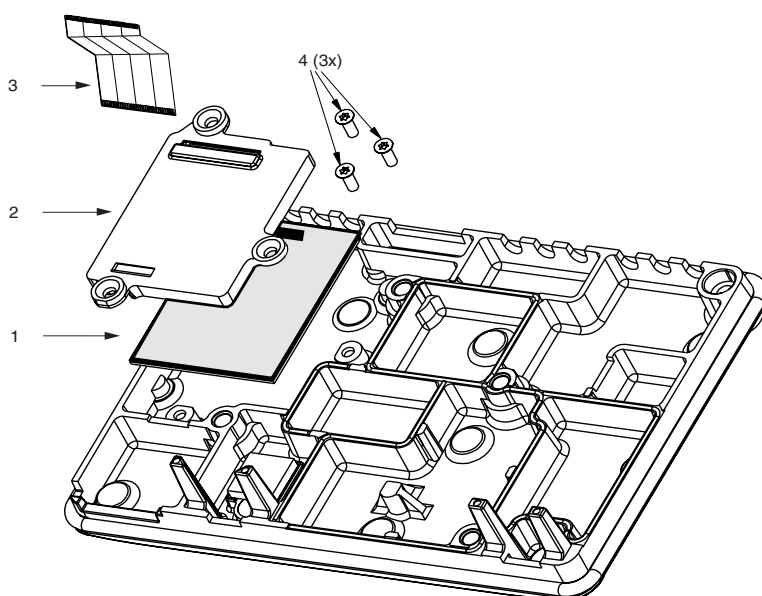

Figure 1 Location of UCM board inside the cover plate

Table 1 UCM Upgrade Kit parts list

Item No.	Description	Part Number
UCM Upgrade Kit:		GMLN4218_
1	UCM Board Module	CLN8041_
2	UCM Board Cover	0786183B01
3	UCM Board Flex	8485615Z02
4	Screw 3x (M5x8)	0310943R55

NOTE: The CLN8041_ UCM board is not repairable. Order a replacement board if necessary.

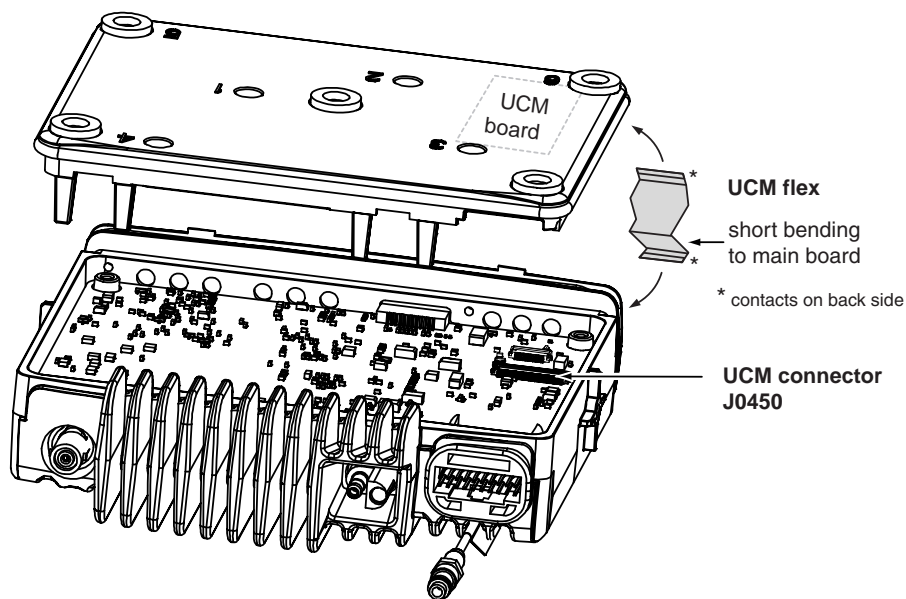

Figure 2 Location of UCM connector J0450 on the main board

UCM Software activation

After installing the UCM hardware, a software upgrade for the MTM800 ENH will be necessary. Please refer to the CPS documentation in the Product Information Manual (P/N: 6866537D87) for more details.

Before use, provision the UCM with E2E Keys and Associations according to your E2E Deployment Plan. This will require a Key Variable Loader (KVL), and may also require configuration changes to your system's Key Management Facility (KMF).

Refer to the **Dimetra End-to-End Encryption KVL 3000 Plus Key Variable Loader User Guide** (P/N: 6802800U14) for more details. For questions refer to your local Customer Support Centre (see Appendix B - Service Information).

THIS PAGE INTENTIONALLY LEFT BLANK

APPENDIX D

PRODUCT SPECIFIC INFORMATION for Digital Terminals Type MT912M

This section gives the Service Personnel an overview about product specific notes. This is necessary to take special precautions to avoid the introduction of hazards when operating, installing, servicing or storing equipment. This terminal meets the applicable safety standards if it is used as described. All operating and safety instructions are to be followed carefully.

Equipment Electrical Ratings

Rated Voltage: 12 Volt DC

Rated Voltage Range: 10.8 to 15.6 V DC

Rated Current:

3 Amps @ 3Watts RF power

Please be aware when planning the installation that there is a current consumption of approx. 3.5A during PTT and even 30mA when terminal is switched off.

Transmitter Frequency Range:

TMO: 806 to 825 MHz

DMO: 851 to 870 MHz

Receiver Frequency Range:

851 to 870 MHz

Normal Load Conditions:

Rated RF Power: 3Watts

Rated Audio Power: 10 Watts @ 4 Ohms; 6 Watts @ 8 Ohms

Antenna Impedance: 50 Ohms

Operating Temp. Range: -30 to +60°C

Operating Time*: Continuous / Intermittent

*Note: In general, the terminal transmit and receive time (operating cycle time) is determined by the communication system. On overload, respectively on extensive use beyond the systems specifications at high ambient temperatures, the terminal is protected by its thermal control, which cuts down the RF output power, thus reducing the terminal coverage range.

Fuse Identification

In case of blown fuses during the installation only replace those with identically value. **Never insert different values.**

Fuse for Power Cable GKN6270/GKN6274: 10A (Motorola Part Number: 65C80283E05)

Fuse for Ignition Sense Cable HKN9327: 4A (Motorola Part Number: 65C80283E02)

SPEZIELLE PRODUKTINFORMATIONEN

für Funkgeräte des Typs MT912M

Dieses Kapitel gibt dem geschulten Servicepersonal einen Überblick über wichtige produktspezifische Informationen. Diese Informationen sind wichtig, um Risiken beim Bedienen, Installieren und Service zu vermeiden. Dieses Funkgerät erfüllt die allgemeinen Sicherheitsstandards, sofern es so betrieben wird, wie in der Bedienungsanleitung beschrieben.

Nennwerte für das Funkgerät

Nennspannung: 12 Volt DC

Nennspannungsbereich: 10.8 bis 15.6 V DC

Nennstrom:

3 A @ 3W HF Leistung

Bevor Sie die Installation planen, bedenken Sie, dass das Sprechfunkgerät beim Senden einen Stromverbrauch von ca. 3,5A hat und auch im ausgeschalteten Zustand einen Strom von ca. 30 mA verbraucht.

Sender-Nennfrequenzbereich:

TMO: 806 bis 825 MHz

DMO: 851 bis 870 MHz

Empfänger-Nennfrequenzbereich:

851 bis 870 MHz

Betriebsbedingungen

HF Nennleistung: 3 Watt

Lautsprecher Nennleistung: 10 Watt an 4 Ohm; 6 Watt an 8 Ohm

Antennenimpedanz: 50 Ohm

Betriebstemperatur Bereich: -30 to +60°C

Betriebszeit*: fortwährend / periodisch

*Hinweis: Im allgemeinen wird die Sende- und Empfangszeit (Betriebszeit) des Funkgerätes durch das Funktionssystem bestimmt. Bei Überlastung bzw. extensivem Betrieb über die Systemsspezifikationen hinaus bei hohen Umgebungstemperaturen wird das Funkgerät durch eine Temperaturkontrollschaltung geschützt, die die HF-Leitung reduziert. Daraus kann sich eine Verringerung der Leistungsmerkmale des Gerätes ergeben.

Sicherungen

Sollte während der Installation die Sicherung durchbrennen, darf sie **nur durch eine gleichwertige** Sicherung ersetzt werden.

Sicherung für DC Kabel GKN6270/GKN6274: 10A (Motorola Bestellnummer: 65C80283E05)

Sicherung für Ignition Sense Kabel HKN9327: 4A (Motorola Bestellnummer: 65C80283E02)